

**Request for Proposal (RfP)**  
**For**  
**Request for Proposal (RfP) for Design, Engineering,  
Procurement & Supply, Construction, Commissioning and  
Comprehensive Operation & Maintenance of cumulative 9  
MW (AC) Grid connected Ground Mounted Solar PV Power  
Plant for a period of 25 years on Government Land at Palamu  
District of Jharkhand**



**Tender reference no.: 12/JREDA/SSP/PAL/2024-25**

Issued by  
**Jharkhand Renewable Energy Development Agency (JREDA)**

3<sup>rd</sup> Floor, S.L.D.C. Building, Kusai Colony, Doranda, Ranchi-834002.

Ph.: 0651-2491161, Fax: 0651-2491165,

E-mail: [info@jreda.com](mailto:info@jreda.com); Website: [www.jreda.com](http://www.jreda.com)

Request for Proposal (RfP) for Design, Engineering, Procurement & Supply, Construction, Commissioning and Comprehensive Operation & Maintenance of cumulative 9 MW (AC) Grid connected Ground Mounted Solar PV Power Plant for a period of 25 years on Government Land at Palamu District of Jharkhand

Tender reference no.: 12/JREDA/SSP/PAL/2024-25

**(TENDER CONDITIONS & SCOPE OF WORKS)**

<b><u>Section-1</u></b>	<b><u>Notice Inviting Tender</u></b>
<b><u>Section-2</u></b>	<b><u>Instruction to Bidders (ITB)</u></b>
<b><u>Section-3</u></b>	<b><u>Bid Data Sheet (BDS) &amp; Qualification Requirements (QR)</u></b>
<b><u>Section-4</u></b>	<b><u>General Conditions of Contract (GCC)</u></b>
<b><u>Section-5</u></b>	<b><u>Special Conditions of Contract (SCC)</u></b>
<b><u>Section-6</u></b>	<b><u>Technical Specifications</u></b>
<b><u>Section-7</u></b>	<b><u>Bid Forms</u></b>
<b><u>Section-8</u></b>	<b><u>Annexures</u></b>

**SECTION-1: NOTICE FOR INVITING BID (NIB)**

**NIB No. 12/JREDA/SSP/PAL/2024-25**



Govt. of Jharkhand  
Energy Department  
**Jharkhand Renewable Energy Development Agency (JREDA)**  
3rd Floor, S.L.D.C. Building, Kusai Colony, Doranda, Ranchi-834002.  
Ph.: 0651-2491161, Fax: 0651-2491165  
E-mail: [info@jreda.com](mailto:info@jreda.com) ; Website: [www.jreda.com](http://www.jreda.com)

**NOTICE FOR INVITING TENDER (NIB)**

**e-Procurement Notice**

Tender reference no.: 12/JREDA/SSP/PAL/2024-25

Dated: 30.08.2024.

1.	Name of the work	<b>Request for Proposal (RfP) for Design, Engineering, Procurement &amp; Supply, Construction, Commissioning and Comprehensive Operation &amp; Maintenance of cumulative 9 MW (AC) Grid Connected Ground Mounted Solar PV Power Plant for a period of 25 years on Government Land at Palamu District of Jharkhand</b>
2.	Estimated Cost	<b>Rs. 92.97 crores (Approx.) including GST and all other Taxes</b>
3.	Completion Timeline	<b>12 Months</b>
	Bid Validity	180 days
4.	Date of publication of NIT on website: <a href="http://jharkhandtenders.gov.in">http://jharkhandtenders.gov.in</a>	Online through <a href="http://www.jharkhandtenders.gov.in">www.jharkhandtenders.gov.in</a>
5.	Date & time of Pre-bid meeting	06.09.2024 (Friday) up to 1:00 PM
6.	Last date & time for receipt of onlinebids	23.09.2024 (Monday) up to 05:00 PM
7.	Submission of Bid fee and EMD through Online Via SBI Payment Gateway of Jharkhand Tenders	23.09.2024 (Monday) up to 05:00 PM
8.	Technical Bid Opening Date	25.09.2024 (Wednesday) at 03:00 PM
9.	Name & address of office inviting tender	Director, Jharkhand Renewable Energy Development Agency (JREDA), 3rd Floor, SLDC Building, Kusai, Doranda, Ranchi- 834002 (Jharkhand)
10.	Contact no. of procurement officer	0651-2491167/68/61
11.	Helpline no. of e-procurement	0651-2491167/68/61

Any corrigendum/addendum can be seen on website: <http://jharkhandtenders.gov.in> & [www.jreda.com](http://www.jreda.com). Further details can be seen on website: <http://jharkhandtenders.gov.in> & [www.jreda.com](http://www.jreda.com)

Sd/-  
Director,  
JREDA, Ranch



**NIB No. 12/JREDA/SSP/PAL/2024-25**

**List of Important dates & Details of Bids**

<b>Sl.No.</b>	<b>Particulars</b>	<b>Details</b>
1.	Name of work	Request for Proposal (RfP) for Design, Engineering, Procurement & Supply, Construction, Commissioning and Comprehensive Operation & Maintenance of cumulative 9 MW (AC) Grid connected Ground Mounted Solar PV Power Plant for a period of 25 years on Government Land at Palamu District of Jharkhand
2.	Contract Period	<b>26 Years ( 1 Year for Supply, Construction and Commissioning + 25 Years for CMC )</b>
3.	Completion Timeline	<b>12 Months ( Twelve months)</b>
4.	Mode of Submission	<b>Online</b> through <a href="http://www.jharkhandtenders.gov.in">www.jharkhandtenders.gov.in</a>
	Estimated Cost	<b>Rs. 92.97 crores (Approx.) including GST and all other Taxes</b>
5.	Bid Validity	<b>180 days</b> from the date of opening of the Price Bid of this Tender
6.	Tender Fees (non-refundable); through Online Via SBI Payment Gateway of Jharkhand Tenders.	<b>Rs. 11,800/- ( Eleven Thousand Eight Hundred only)</b>
7.	Earnest Money Deposit (EMD) (Refundable); through Online Via SBI Payment Gateway of Jharkhand Tenders. {This is mandatory}	<b>Rs. 1, 86,00,000/- (One Crore Eighty-Six Lakh Only)</b>
8.	EMD Validity	180 days
9.	Security Deposit for Contract Period in form of BG/TDR/FDR/DD	Successful bidders need to submit a Contract security deposit @10% of the Total Contract Value in the form of DD/BG/FDR within thirty (30) days from the date of issue of Letter of Intent (LoI)/LOA. Contract security for contract period shall be valid for a period of Twelve Months (12 months) from the date of issue of LoA/Work Order or till the date of successful completion of Operational Acceptance Test (OAT) or Commercial operation Date (COD) whichever is earlier. <b>Please refer to detailed clause-6 in Section-5 (SCC).</b>
10.	O&M Performance Security Deposit (25 Years O&M service BG) in	5% of the of Total Contract value, to be submitted before initiation of O&M period (25 years) of the

	form of BG/TDR/FDR/DD	<p>Project i.e., actual commercial operation date of the plant ( should be within 12 months) and BG shall be valid minimum up to 5 years and aggregate period of Twenty-Five (25) years from the initiation of O&amp;M period. Successful Bidder shall submit BG with minimum validity of 5 years initially and shall submit a new BG with 5 years validity on expiry of the existing submitted BG. This process shall be repeated by the Successful Bidder at every five-year block.</p> <p>This O&amp;M BG shall cover the risk against warrantee for equipment's and performance generation up to O&amp;M Period and recovery towards shortfall in NEEGG during O&amp;M Period.</p> <p><b>Please refer to detailed clause-7 in Section-5 (SCC)</b></p>
12.	Date of upload of this Tender	02.09.2024 (Monday)
13.	Last date and time for receipt of questions/ queries/ clarifications at info@jreda.com	09.09.2024 (Monday) up to 1:00 PM
14.	Pre-Bid Meeting Date	06.09.2024 (Friday) up to 1:00 PM
15.	Last date and time of On-line (e-tendering) tender/offer submission (the "Bid Submission Deadline") <b>[This is mandatory]</b>	23.09.2024 (Monday) up to 05:00 PM
16.	Submission of Bid fee and EMD through Online Via SBI Payment Gateway of Jharkhand Tenders. <b>[This is mandatory]</b>	23.09.2024 (Monday) up to 05:00 PM
17.	Opening of Technical Bid	25.09.2024 (Wednesday) at 03:00 PM
18.	Tentative date of opening of online Financial Bid	To be intimated later
19.	Authority inviting bids	Director, Jharkhand Renewable Energy Development Agency (JREDA), 3rd Floor, SLDC Building, Kusai, Doranda, Ranchi 834502. Website: www.jreda.com Email:info@jreda.com

*Note: The abovementioned dates & details are subject to change, in case of amendments details shall be intimated*

**Sd/-  
Director,  
JREDA, Ranchi**



## NIB No. 12/JREDA/SSP/PAL/2024-25

### Important Note to Bidders

1. The bidders have to submit their bids online in electronic format with digital Signature along with Scan Copy of Challan / Receipt of Tender Fee and EMD submission through Online Via SBI Payment gateway of Jharkhand Tender. The bids without digital signature will not be accepted. No proposal will be accepted in physical form. Otherwise, the offer will not be considered and no further communication in the matter will be entertained. Please note that Bid is not to be submitted in physical form.
2. No Tender shall be accepted in any case after due date and time of receipt of the Tender, irrespective of delay due to any reasons circumstantial or otherwise and JREDA does not assume any responsibility for late receipt of the Tender.
3. All interested parties are requested to understand this Tender in detail in order to comply with JREDA's requirements including but not limited to the fees and deadlines, selection criteria, selection methodology, scope of work, and minimum technical standards. They shall strictly abide by ALL terms prescribed in this Tender and provide accurate information to the best of their knowledge without misleading the Company to be considered for participation in this Project.
4. It is mandatory for all the bidders to submit their Technical and Financial Bid ONLINE only via e-tendering portal.
5. Technical Bid (techno-commercial Bid): It is mandatory for all the bidders to submit their Technical Bid (Techno-commercial Bid) Scan copy of documents & Transition receipt of Tender Fee & EMD through online (e-tendering) in scheduled time. Technical Bid in hard copy (physical form) shall not be considered.
6. Tender Fee and EMD shall be submitted through Online Via SBI Payment gateway of Jharkhand Tenders.
7. It is mandatory for all bidders to submit their PRICE-BID only through online (e-tendering). Price bid submitted in physical form will not be considered for its opening and only online submitted price bid will be considered for evaluation. Bidders to note that Price Bid of those bidders shall be opened (Online/e-tendering) who is found technically qualified and is found reasonably responsive to JREDA's tender terms and conditions and Scope of Works.
8. All the Bidders shall fulfil the pre-qualification criteria as stipulated in the RfP.
9. **Any technical/commercial query pertaining to this Tender should be referred to:**  
**Director,**  
Jharkhand Renewable Energy Development Agency (JREDA)  
3rd Floor, SLDC Building, Kusai, Doranda, Ranchi- 834002 (Jharkhand)
10. **Alternate Contact Details:**  
Shri. Atilesh Gautam (EEE) - +91 7903935514
11. JREDA reserve the rights to accept/reject any or all tenders without assigning any reasons thereof. Bidders are requested to be in touch with above-mentioned websites till opening of the price bid to know the latest status.

## **Disclaimer**

1. Though adequate care has been taken while preparing the RfP document, the bidder(s) shall satisfy themselves that the document is complete in all respect. Intimation regarding any discrepancy shall be given to the office of JREDA immediately. If no intimation is received from any bidder within 20 (Twenty) days from the date of issuance of RfP documents, it shall be considered that the document is complete in all respect and has been received/ acknowledged by the bidder(s).
2. Jharkhand Renewable Energy Development Agency (JREDA) reserves the right to modify, amend or supplement this document.
3. While this RfP document has been prepared in good faith, neither JREDA nor their employees or advisors make any representation or warranty, express or implied, or accept any responsibility or liability, whatsoever, in respect of any statements or omissions herein, or the accuracy, completeness or reliability of information, and shall incur no liability under any law, statute, rules or regulations as to the accuracy, reliability or completeness of this document, even if any loss or damage is caused by any act or omission on their part.
4. JREDA reserves the right to cancel/withdraw this Invitation for Bids without assigning any reason for such decision.
5. The information provided in the Bid Documents to the Bidders is on a wide range of matters, some of which may depend upon interpretation of the law. The information given is not intended to be an exhaustive account of statutory requirements and should not be regarded as a complete or authoritative statement of the law. JREDA, its employees and advisors accept no responsibility for the accuracy or otherwise for any interpretation or opinion on laws expressed in the Bid Documents.
6. JREDA and its employees and advisors make no representation or warranty and will have no liability to any Person, including any Bidder, under any law, statute, rules or regulations or tort or otherwise for any loss, damage, cost or expense which may arise from or that may be incurred or suffered on account of anything contained in the Bid Documents or otherwise, including the accuracy, adequacy, correctness, completeness or reliability of the Bid Documents and any assessment, assumption, statement or information contained in the Bid Documents or deemed to form part of the Bid Documents or arising in any way.
7. JREDA and its employees and advisors also accept no liability of any nature, whether resulting from negligence or otherwise, however caused arising from reliance of any Bidder upon the content of the Bid Documents.
8. The issue of the Bid Documents does not imply that JREDA is bound to qualify any Bidder or to award the project to any Bidder. JREDA reserves the right to reject all or any of the Bids without assigning any reasons whatsoever.
9. The statements and explanations contained in this RFP, and any other Bid Documents are intended to provide an understanding to the Bidders about the subject matter of this RFP and should not be construed or interpreted as limiting in any way or manner the obligations of the Selected Bidder(s) that will be set out in the Project Agreements or JREDA's right to amend, alter, change, supplement

or clarify the Units' scope or the terms of this RFP or the Project Agreements. Consequently, any omissions, conflicts, or contradictions in the Bid Documents (including this RFP) are to be noted, interpreted, and applied appropriately to give effect to this intent, and no claims on that account shall be entertained by JREDA.

10. The Bidders shall bear their own costs associated with or relating to the preparation and submission of their Bids, including copying, postage, delivery charges and expenses associated with any demonstrations or presentations which may be required by JREDA, or any other costs incurred in connection with or relating to their Bids. All such costs and expenses will be borne by Bidders, and JREDA and its employees and advisors will not be liable in any manner whatsoever for such costs and expenses, regardless of the conduct or outcome of the Bid Process.

**NOTE:**

*This is an e-tender. Offers shall be submitted and processed in electronic mode only. Physical copies of required document will additionally need to be supplied for verification. The instructions to bidder/terms and conditions appearing in this specification only shall be applicable.*

## Table of Contents

<b>SECTION-1: NOTICE FOR INVITING BID (NIB)</b> .....	3
e-Procurement Notice .....	4
List of Important dates & Details of Bids .....	5
Important Note to Bidders .....	7
Disclaimer .....	8
<b>SECTION-2: INSTRUCTIONS TO BIDDERS (ITB)</b> .....	19
<b>1. Introduction</b> .....	20
<b>2. Detailed instructions &amp; documents to be furnished for online bidding.</b> .....	20
<b>3. General Instructions</b> .....	21
<b>4. Source of Funds</b> .....	22
<b>5. One Bid per Bidder</b> .....	23
<b>6. Description of Bid Process</b> .....	23
<b>7. Qualified Bidder</b> .....	23
<b>8. Financial Proposal</b> .....	23
<b>9. Clarifications on Bid Documents and Pre-Bid Meetings</b> .....	23
<b>10. Amendment of Bid Documents</b> .....	25
<b>11. Preparation of Bids</b> .....	25
<b>12. Bid Prices</b> .....	27
<b>13. Bid Validity</b> .....	27
<b>14. Currencies of Bid and Payment</b> .....	27
<b>15. Bid Security</b> .....	28
<b>16. Submission of Bids</b> .....	29
<b>17. Deadlines for Submission of Bids</b> .....	29
<b>18. Late Bids</b> .....	29
<b>19. Modification and Withdrawal of Bids</b> .....	29
<b>20. Right to accept any bid and to reject any or all bids</b> .....	29
<b>21. Evaluation of Proposal</b> .....	30
<b>22. Criteria for Selecting bidder</b> .....	32
<b>23. Letter of Intent (“LOI”) and Notification to Proceed</b> .....	32
<b>24. Notification of Award and Issuance of LOA/WO</b> .....	32
<b>25. Signing of Agreement</b> .....	32
<b>26. Handing Over Asset</b> .....	33
<b>SECTION-3: BID DATA SHEET &amp; QUALIFICATION REQUIREMENTS (QR)</b> .....	34
<b>1. Bid Data Sheet</b> .....	35
<b>2. Pre-Qualifying Requirements (PQRs)/ Eligibility Conditions</b> .....	38

<b>SECTION-4: GENERAL CONDITIONS OF CONTRACT (GCC)</b> .....	44
<b>1. Introduction</b> .....	44
<b>2. Bid Document</b> .....	45
<b>3. Inspection of the factory and Tests</b> .....	45
<b>4. Dispatch Instructions</b> .....	45
<b>5. Project Management Consultant and Third-Party Inspection Agency</b> .....	46
<b>6. Guarantee &amp; Warranty</b> .....	46
<b>7. Risk &amp; Cost</b> .....	46
<b>8. Arbitration</b> .....	46
<b>9. Insurance</b> .....	46
<b>10. Assignment/ Sub-letting</b> .....	47
<b>11. Project Report</b> .....	47
<b>12. Project Inspection</b> .....	47
<b>13. Compliance with Regulations</b> .....	47
<b>14. Income Tax</b> .....	47
<b>15. Training Program, After Sales Service and Availability of Spare Parts</b> .....	47
<b>16. Corrupt or Fraudulent Practices</b> .....	48
<b>17. Indemnity</b> .....	48
<b>18. Completeness of Tender</b> .....	48
<b>19. Force Majeure conditions</b> .....	48
<b>20. Confidential Information and Proprietary Data</b> .....	49
<b>21. Rights of JREDA</b> .....	49
<b>22. Governing Law</b> .....	50
<b>23. Jurisdiction of the Court</b> .....	50
<b>SECTION-5: SPECIAL CONDITIONS OF CONTRACT (SCC)</b> .....	51
<b>1. Scope of work</b> .....	52
<b>2. Estimated Timeline of Project Completion</b> .....	65
<b>3. Contract Price</b> .....	67
<b>4. Location of Site (s)</b> .....	67
<b>5. Payment terms and conditions:</b> .....	67
<b>6. Performance Security for CMC Period of 25 Years</b> .....	71
<b>7. 25 Years Comprehensive Maintenance Contract (CMC)</b> .....	72
<b>8. Net Electrical Energy Generation Guarantee (NEEGG)</b> .....	73
<b>9. Penalty for Loss of Generation during O&amp;M</b> .....	74
<b>10. Preventive/Routine Maintenance</b> .....	74
<b>11. Breakdown / corrective Maintenance</b> .....	74

<b>12. Liquidated Damages for Delay in Completion &amp; CMC</b> .....	74
<b>SECTION-6: TECHNICAL SPECIFICATIONS</b> .....	75
<b>1. Technical Specification</b> .....	76
<b>2. Minimum assured items/Components services and technical specifications</b> .....	76
<b>3. Detailed Civil and Other Non-Electrical Work</b> .....	123
<b>SECTION-7: BID FORMS</b> .....	134
DOCUMENT CHECKLIST .....	135
FORM-1: FORMAT FOR COVERING LETTER .....	136
FORM-2: INFORMATION ABOUT THE BIDDING FIRM.....	137
FORM-3: DECLARATION BY THE BIDDER.....	138
FORM-4: FORMAT OF POWER OF ATTORNEY FOR BIDDING COMPANY .....	139
FORM-5: FORMAT OF POWER OF ATTORNEY FOR JOINT VENTURE/CONSORTIUM.....	141
FORM-6: FORMAT FOR CONSORTIUM/JOINT VENTURE AGREEMENT .....	143
FORM-7: LETTER OF INTENT BY JV/CONSORTIUM PARTNERS TO ENTER INTO AGREEMENT/FORM JV or CONSOURTIUM.....	147
FORM-8: AUTHORIZED CONTACT PERSON FOR THE NIB .....	151
FORM-9: FORMAT OF NO DEVIATION CERTIFICATE.....	152
FORM-10 FORMAT FOR FINANCIAL REQUIREMENT – ANNUAL TURNOVER.....	153
FORM-11: FORMAT FOR FINANCIAL REQUIREMENT - NET WORTH CERTIFICATE.....	156
FORM-12: PROJECT EXPERIENCE REQUIREMENT .....	159
FORM-13: FORMAT OF DETAILS OF QUALIFIED TECHNICAL STAFF .....	160
FORM-14: FORMAT OF DISCLOSURE OF PV TECHNOLOGY PROPOSED .....	161
FORM-15: FORMAT OF DECLARATION OF COMPLIANCE.....	162
<b>SECTION-8: ANNEXURES</b> .....	163
ANNEXURE-1: FORMAT OF PRICE BID .....	164
ANNEXURE-2: FORMAT FOR PRICE BREAKUP FOR SUPPLY & SERVICES .....	166
ANNEXURE-3: PRICE QUOTE FOR O&M CONTRACT.....	168
ANNEXURE 4: BID EVALUATION CRITERIA (BEC) .....	171
ANNEXURE 5: PROCEDURE FOR PERFORMANCE TESTING .....	172
ANNEXURE-6: DELIVERY REPORT FORMAT .....	176
ANNEXURE-7: PROJECT COMPLETION CERTIFICATE .....	177
ANNEXURE-8: DECLARATION FORMAT ASSOCIATED WITH OF ALMM ORDER .....	178
ANNEXURE 9: FORMAT OF PERFORMANCE BANK GUARANTEE .....	179
ANNEXURE-10: FORMAT FOR MONTHLY O&M AND CMC REPORT .....	183
ANNEXURE 11: DETAILS OF PLANT LOCATION AND SITE ANALYSIS.....	187

## Glossary

In this RFP, unless the context otherwise requires, capitalized terms shall have the meaning given to them in the table below.

<b>Act</b>	"ACT" or "ELECTRICITY ACT, 2003" shall mean the Electricity Act, 2003 and include any modifications, amendments and substitution from time to time.
<b>ALMM</b>	"ALMM" shall means Approved Models and Manufactures of Solar Photovoltaics Modules issued via OM no. 283/22/2023-Grid Solar dated 10th May 2023 and its latest updated list dated 24th May 2024 and amendments issue time to time. The successful bidder shall comply to the above requirement mandatorily
<b>Approved</b>	APPROVED shall mean approved in writing including subsequent written confirmation
<b>Bid</b>	means the Proposal/documents submitted by Bidders towards meeting techno-commercial and financial qualification requirements for the awarding the Unit (s)/Work/Allocation of Capacity/Quantity, comprising of online submissions in accordance with Section-2 ITB Clause 2, and discovery of L1 rates for system specified in this bid and <b>Bid</b> shall mean any one of them.
<b>BIS</b>	"B.I.S." shall mean specifications of Bureau of Indian Standards (BIS).
	"BIDDING CONSORTIUM" or "CONSORTIUM" shall refer to a group of Companies that collectively submit the response in accordance with the provisions of this RfP under a Consortium Agreement.
<b>Bidder</b>	"BIDDER" shall mean Bidding Company or a Bidding Consortium submitting the Bid. Any reference to the Bidder includes Bidding Company/ Bidding Consortium, Member of a Bidding Consortium including its successors, executors and permitted assigns and Lead Member of the Bidding Consortium jointly and severally, as the context may require;
<b>Bid Capacity</b>	"BID CAPACITY" shall mean aggregate project capacity/quantity of the Solar PV Power Project(s) as proposed by the Bidder.
<b>Calendar Year</b>	means a year commencing on 1 January and ending on 31 December.
<b>Clause</b>	means a clause of this RFP.
<b>Company or Bidding Company</b>	means a body corporate incorporated in: (a) India under the Companies Act, 1956 or the Companies Act, 2013, as applicable; or (b) any other country, in accordance with the applicable laws of the country of incorporation.
<b>COD</b>	"COMMERCIAL OPERATION DATE (COD)" shall mean as defined as plant starts generating electricity as per NEEGG post achieving OAT
<b>Competent Authority</b>	Competent Authority shall have the meaning ascribed to in the Office

	Memorandum.
<b>Corrigendum or Corrigenda</b>	Corrigendum or Corrigenda means a corrigendum or corrigenda to the RFP.
<b>CEA</b>	“CEA” shall mean Central Electricity Authority.
<b>CA</b>	“CHARTERED ACCOUNTANT (CA)” shall mean a person practicing in India or a firm whereof all the partners practicing in India as a Chartered Accountant(s) within the meaning of the Chartered Accountants Act, 1949. For Bidders incorporated in countries other than India, “Chartered Accountant” shall mean a person or a firm practicing in the respective country and designated/ registered under the corresponding Statutes/ laws of the respective country.
<b>Company</b>	shall mean a body corporate incorporated in India under the Companies Act, 2013 or any law in India prior thereto relating to Companies, as applicable.
<b>Contracted/Allocated Capacity</b>	shall mean the AC capacity in kW/MW contracted with the vendors for installation and commissioning of the plants.
<b>Contract Document</b>	mean collectively the Tender Documents, Designs, Drawings, Specification, Schedule of Quantities and Rates, Notification of Award/ Letter of Intent/ Letter of Acceptance and agreed variations if any, and such other documents constituting the Tender and acceptance thereof.
<b>Contractor’s Equipment</b>	means all plant, facilities, equipment, machinery, tools, apparatus, appliances or things of every kind required in or for installation, completion and maintenance of Facilities that are to be provided by the Contractor, but does not include Plant and Equipment, or other things intended to form or forming part of the Facilities.
<b>Contract Price/Contract Value/Project Value</b>	means the firm value of the final quoted price, as a result of e- RA (if applicable), by the successful bidder specified in its financial proposal as the sum of individual contract value of Supply & Services (Supply of goods, F&I, Design, installation, Civil Works etc) as mentioned under the different work heads specified in the financial proposal including all the applicable taxes/ Goods & Service taxes.
<b>Commissioning</b>	means a project shall be considered commissioned if all equipment as per rated capacity, mentioned under the scope of contract, has been installed and energy has flown into grid.
<b>Completion of the Project</b>	means that the Project (or a specific part thereof where specific parts are specified in the SCC) have been completed operationally and structurally and put in a tight and clean condition, and that all work in respect of Pre-commissioning of the Facilities or such specific part thereof has been completed; and Commissioning along with Operational Acceptance has been attained as per Technical Specifications.

<b>CUF</b>	“Capacity Utilization Factor (CUF)” shall have the same meaning as provided in CERC (Terms and Conditions for Tariff determination from Renewable Energy Sources) Regulations, 2009 as amended from time to time.
<b>Data Room</b>	means the virtual data room that will be open to Bidders and their advisors from the date specified in Schedule 1 until the Proposal Due Date.
<b>Delivery Point</b>	shall have the meaning ascribed to in the Power Purchase Agreement.
<b>Developer</b>	means an entity who has either executed or got executed the work/project as owner of solar projects.
<b>E-bidding Portal</b>	It is clarified that, on the E-bidding Portal, the term ‘E-bidding Portal’ is referred to as URL: <a href="https://jharkhandtenders.gov.in/">https://jharkhandtenders.gov.in/</a> .
<b>Empaneled Vendor/Agency</b>	Shall mean technically and financially successful bidders whose awarded the work and they accepted the offer
<b>Effective Date</b>	shall mean the date of signing of the agreement with vendors for execution of work
<b>Equity</b>	shall mean the sum expressed in INR representing the paid-up share capital of the SPD for meeting the equity component of the project, and shall include convertible instruments or other similar form of capital, which shall compulsorily convert into equity share capital of the SPD and any subordinated shareholder loan.
<b>Eligible Bidder</b>	means a Bidder who is determined to be eligible to participate in the bid process on the basis of responsiveness check of its Technical and Financial Proposal, in accordance with BDS Clause 2.
<b>Financial Capacity</b>	has the meaning ascribed to it in BDS Clause 2 (PQRS).
<b>Financial Proposal</b>	has the meaning ascribed to it in ITB Clause 8 of section 2.
<b>Financial Year</b>	means a year commencing on 1 April of any Calendar Year and ending on 31 March of the following Calendar Year.
<b>Final Acceptance/Final Completion</b>	means acceptance of Facilities by the EMPLOYER within due date of implementation mentioned in the timeline. final acceptance of the project terms of Operational Acceptance and upon demonstration of minimum annual parameters as specified in the technical specifications and completion of works under the punch list which certifies the Contractor’s fulfilment of the Contract in respect of Functional and Plant Performance Guarantees of the Facilities.
<b>Guarantee Test(S)</b>	means the test(s) specified in the Technical Specifications to be carried out to ascertain whether the Facilities or a specified part thereof is able to attain the Functional Guarantees specified in the Technical Specifications during/ after successful Commissioning followed by Trial - Operation.
<b>GoI</b>	means the Government of India.
<b>GoJ</b>	means the Government of Jharkhand.
<b>Goods &amp; Service Tax</b>	means taxes or cess levied under the Central Goods and Services Tax

<b>(GST)</b>	Act, Integrated Goods and Services Tax Act, Goods and Services Tax (Compensation to States) Act and various State/Union Territory Goods and Services Tax Laws and applicable cess, if any under the laws in force (hereinafter referred to as relevant GST Laws) w.e.f. 01.07.2017, which shall be fully complied with by Bidders.
<b>INR</b>	means Indian Rupees, the lawful currency of the Republic of India.
<b>Installation Services</b>	means all those services ancillary to the supply of the Plant and Equipment for the Facilities, to be provided by the Contractor under the Contract; e.g., transportation and provision of marine or other similar insurance (s), inspection, expediting, site preparation works (including the provision and use of Contractor's Equipment and the supply of all structural and construction materials required), installation including civil and allied works etc., testing, pre-commissioning, commissioning, operations, maintenance, the provision of operations and maintenance manuals, training of EMPLOYER's Personnel etc..
<b>IEC</b>	"IEC" shall mean specifications of International Electro-Technical Commission.
<b>JREDA</b>	means Jharkhand Renewable Development Agency (JREDA) which is a State Nodal Agency (SNA) under the administrative control of the Energy Dept., Gov. of Jharkhand established for execution of programs and promotion of schemes on non-conventional energy sources. JREDA shoulders responsibility as a State Nodal Agency for the Ministry of New & Renewable Energy Sources.
<b>JSERC</b>	means the Jharkhand State Electricity Regulatory Commission.
<b>JBVNL</b>	means Jharkhand Bijli Vitran Nigam Limited.
<b>JBA</b>	means a binding joint bidding agreement to be entered into by the Members of a Consortium, substantially.
<b>kWh</b>	kWh shall mean Kilo-Watt-hour.
<b>kWp</b>	MWp means Mega-Watt
<b>kW (AC)</b>	mean Kilo peak (after conversion from DC to AC )
<b>Lead Member</b>	in the context of a Consortium, means the Member who contributes at least 51% (fifty one percent) of the required Avg. Annual Turnover for qualification, commits to hold the required Equity in the SPV and is authorized by the other Members of the Consortium, to act as the lead member with the rights and obligations set out in this RFP.
<b>LOA</b>	means, with respect to the Unit/Quantity with capacity, a letter of award that will be issued by JREDA to the Selected Bidder for the Unit in accordance with the terms of this RFP.
<b>MWp</b>	MWp means Mega-Watt Peak
<b>MWh</b>	MWh means Mega-Watt Hour.
<b>MW (AC)</b>	mean megawatt peak (after conversion from DC to AC)

<b>MNRE</b>	MNRE means Ministry of New and Renewable Energy, Government of India.
<b>Mobilization</b>	shall mean establishment of sufficiently adequate infrastructure by the Contractor at Site comprising of construction equipment, aids, tools tackles including setting of site offices with facilities such as power, water, communication etc. establishing manpower organization comprising of Resident Engineers, Supervising Personnel and an adequate strength of skilled, semi-skilled and unskilled workers, who with the so established infrastructure shall be in a position to commence execution of work at site(s), in accordance with the agreed Time Schedule of Completion of Work. Mobilization shall be considered to have been achieved, if the Contractor is able to establish infrastructure as per Time Schedule, where so warranted in accordance with agreed schedule of work implementation to the satisfaction of Engineer-in-Charge/Project Manager.
<b>Member</b>	means a member of a Consortium/JV.
<b>MNRE</b>	means the Ministry of New and Renewable Energy, GoI.
<b>MoP</b>	means the Ministry of Power, GoI.
<b>Net-Worth</b>	shall have same meaning as defined in Company Act 2013 and Amendment, if any.
<b>NEEGG</b>	The Bids with <b>Net Electrical Energy Generation Guarantee (NEEGG)</b> of less than 16,514,495 kWh for the First Year for 9 MW(AC) Ground Mounted Solar Project shall be summarily rejected
<b>Operational Acceptance</b>	means the acceptance of the Plant Facilities (or any part of the Facilities where the Contract provides for acceptance of the Facilities in parts) by the JREDA , which certifies the Contractor's fulfilment of the Contract in respect of meeting Plant Functional and Performance Guarantees of the Facilities and completion of works.
<b>O &amp; M</b>	means comprehensive Operation & Maintenance of Commissioned Project/ Work/ Facilities under the contract.
<b>OWNER</b>	means the Company/ Corporation/ Government Entity, named in the BDS/ SCC, who has decided to set up the Facilities under his ownership at his designated location and shall include the legal successors or permitted assigns of the Owner.
<b>Paisa</b>	means one-hundredth of INR.
<b>Parent</b>	shall mean a company that holds more than fifty percent (50%) of the paid-up equity capital directly or indirectly in the Bidding Company or in a Member of a Bidding Consortium, as the case may be.
<b>Person</b>	means any corporation, company, partnership, limited liability company, association, joint stock company, trust, unincorporated organization, joint venture or other legally recognized entity of

	whatever nature.
<b>Plant and Equipment</b>	means permanent plant, equipment, machinery, apparatus, articles and things of all kinds to be provided and incorporated in the Facilities by the Contractor under the Contract (including the spare parts to be supplied by the Contractor) but does not include Contractor's Equipment.
<b>Pre-Bid Meeting</b>	has the meaning ascribed to it in Section-1; list of important dates
<b>Procurer</b>	Shall mean JBVNL
<b>Proposal</b>	means collectively the Qualification Proposal and the Financial Proposal, to be submitted by the Bidders in accordance with this RFP.  It is clarified that, on the E-bidding Portal, 'Proposal' is referred to as 'Bid' or 'Tender'.
<b>Proposal Due Date</b>	means the last date specified in Schedule 1 for submission of the Proposal. It is clarified that, on the E-bidding Portal, 'Proposal Due Date' is referred to as 'Last Date and Time of Receipt of Bids'.
<b>Pre-Commissioning</b>	means the testing, checking and other requirements specified in the Technical Specifications that are to be carried out by the Contractor in preparation for Commissioning.
<b>Qualification Proposal</b>	means the qualification proposal, comprising of the documents set out in ITB Clause 11, to be submitted by a Bidder as a part of its Bid pursuant to this RFP. It is clarified that, on the E-bidding Portal, 'Qualification Proposal' is referred to as 'Technical-Part' or 'Technical Envelope' or 'Technical Bid-Part'.
<b>Qualified Bidders</b>	has the meaning ascribed to it in ITB Clause 7.
<b>RFP</b>	means this Request for Proposal.
<b>Schedule</b>	means a schedule to this RFP in Section-1.
<b>SCSD</b>	Scheduled Commencement-of-Supply Date

## **SECTION-2: INSTRUCTIONS TO BIDDERS (ITB)**

**NIB No. 12/JREDA/SSP/PAL/2024-25**

## **SECTION-2: INSTRUCTIONS TO BIDDERS (ITB)**

### **1. Introduction**

Jharkhand Renewable Development Agency (JREDA) is a State Nodal Agency (SNA) under the administrative control of the Energy Dept., Gov. of Jharkhand established for execution of programmes and promotion of schemes on non-conventional energy sources. JREDA shoulders responsibility as a State Nodal Agency for the Ministry of New & Renewable Energy Sources.

JREDA has been implementing various programs of non-conventional energy sources for energy generation through utility scale solar plant, grid connected rooftop solar plants, canal top solar plants, small hydel projects etc. It works towards providing sustainable energy to the People of Jharkhand and works towards sustainable tomorrow. JREDA has been instrumental in envisioning the policy architecture for implementation of Renewable Energy Policy and formulates innovative policies that transform challenges into opportunities and in turn in the success to overcome the barriers. Government of Jharkhand had come out with Jharkhand Solar Power Policy 2022 with an aim to develop solar power generation capacity of 4000 MW by FY 2026-27.

Jharkhand Renewable Energy Development Agency (JREDA) being a nodal agency for the state of Jharkhand; invited interested parties to participate in this “RFP” for bidding and selection process for the appointment of Contractor for “*Request for Proposal (RfP) for Design, Engineering, Procurement & Supply, Construction, Commissioning and Comprehensive Operation & Maintenance of cumulative 9 MW (AC) Grid connected Ground Mounted Solar PV Power Plant for a period of 25 years on Government Land at Palamu District of Jharkhand.*” (the “Project”). The Cumulative capacity 9 MW (AC) grid-connected Ground Mounted solar PV Project is to be developed at Parta Village, Palamu of Jharkhand state. Proposed sites are at Vill.: Parta, Circle: Haidarnager, Palamu District which have Estimated Capacity of 09 MW (AC)

<b>Locations</b>	<b>Land area in (Acre)</b>	<b>Capacity in (MW)</b>	<b>Co-ordinates of Locations</b>	<b>Respective JBVNL / JUSNL S/s with approximate distance from location.</b>
Vill.: Parta, Block.: Haidarnagar, Dist.: Palamu	50	09 MW	Latitude: 24.5280661 Longitude: 83.9204249	JBVNL, 33/11 KV Deori S/s @ Approx. 05 – 07 KM

### **2. Detailed instructions & documents to be furnished for online bidding.**

- 2.1.** The guidelines to submit bid online can be downloaded from website <http://Jharkhandtenders.gov.in>
- 2.2.** The interested bidders can download the bid from the website “<http://Jharkhandtenders.gov.in>”.
- 2.3.** To participate in bidding process, bidders have to get ‘Digital Signature Certificate (DSC)’ as per Information Technology Act-2000 to participate in online bidding. This certificate will be required for digitally signing the bid. Bidders can get above mention digital signature certificate

from any approved vendors (CCA). Bidders, who already possess valid Digital Certificates, need not to procure new Digital Certificate.

- 2.4. The bidders have to submit their bids online in electronic format with digital Signature. The bids without digital signature will not be accepted. No proposal will be accepted in physical form.
- 2.5. Bids will be opened online as per time schedule mentioned in section 1
- 2.6. Bidders should get ready with the scanned copies of cost of documents & EMD as specified in the tender document. Before submission of online bids, bidders must ensure that scanned copy of all the necessary documents have been attached with bid.
- 2.7. Uploaded documents of valid successful bidders will be verified with the original before signing the agreement. The valid successful bidder must provide the originals to the concerned authority.
- 2.8. The department will not be responsible for delay in online submission due to any reason.
- 2.9. All the required information for bid must be filled and submitted online. If the bid is not found to be uploaded online on the website (<http://Jharkhandtenders.gov.in>), bid shall be rejected even though the bidder/s have submitted Bid fee & EMD. No hard copy is required to be submitted in the office of JREDA.
- 2.10. Other details can be seen in the bidding documents.
- 2.11. Contractor Registration in JREDA is mandatory to participate in this tender.
- 2.12. **Details of documents to be furnished for online bidding as per ITB clause 11 (Preparation of Bids).**

**2.13. Duly filled in & digitally signed Price Bid.**

Uploaded documents of valid successful bidders will be verified with the original before signing the agreement. The valid successful bidder has to provide the originals to the concerned authority on receipt of such letter, which will be sent through registered post.

**2.14. If not uploaded Signed SBD (Tender Document)**

The bidder shall submit an affidavit agreeing on all the terms and conditions within the SBD. The bidders, who disagree on the conditions of SBD, cannot participate in the tender.

### **3. General Instructions**

- 3.1. The current document is the RFP, which is issued to all the potential Bidders, requesting a Bid for implementation of the Project on a fixed price basis. A Solar Power Developer would be selected through competitive bidding process for execution of the Project.
- 3.2. Any information regarding Tender can be obtained from the office of Director at ([info@jreda.com](mailto:info@jreda.com)) on any working day prior to last date of submission of Tenders.
- 3.3. The payment of Tender Document Fee and EMD can be made through Online Via SBI Payment Gateway of Jharkhand Tenders. Bidder shall deposit the bid security & tender fee in online mode as per rules of e-tendering portal. A Standard Operating Procedure for online collection of Tender Fee and Earnest Money Deposit by Government of Jharkhand can be downloaded from [Jharkhandtenders.gov.in](http://Jharkhandtenders.gov.in) as a part of this tender document.
- 3.4. Unless exempted specifically, Tenders not accompanied with the prescribed EMD and Tender Fees shall be rejected. EMD / Tender Fees shall be in the prescribed mode of payment as asked in the NIB otherwise the Tender shall be liable to be rejected.

- 3.5. Before submitting Tenders, the instructions may be read carefully regarding submission of Tender. If any bidder finds discrepancies or omissions in the Tender documents or is in doubt as to the true meaning of any part, he shall clarify same from the Tender issuing office in writing before the due date of submission of the queries.
- 3.6. The validity of the EMD shall be 180 days from the last date of receipt of bids with a claim period of another thirty (30) days thereafter.
- 3.7. The details of NIB along with Tender Documents can be seen and downloaded from the portal <http://jharkhandtenders.gov.in> as well as JREDA website [www.jreda.com](http://www.jreda.com).
- 3.8. The committee nominated by JREDA shall evaluate all the Bids received against NIB on the parameter indicated under heading Pre-Qualifying Requirement (PQRs)/ Eligibility conditions and other relevant clause of the Tender. The decision of the committee shall be final.
- 3.9. Issuance of Tender Documents to any party shall not construe that such party is considered to be qualified.
- 3.10. In case due dates of sale / receipt /opening of the Tender happens to be holiday in JREDA, the needful will be done on next working day.
- 3.11. The Bidders / Contractors shall observe the highest standards of ethics during the submission of Tender, procurement, and execution of the Contract. In case of evidence of cartel formation by the Bidder(s) EMD is liable to be forfeited.
- 3.12. The Bidder shall bear all costs including bank charges if any, associated with the preparation and submission of this Bid and the purchaser will in no case be responsible or liable for those costs, regardless of the conduct or outcome of the bidding process.
- 3.13. Tender Issuing Authority reserves the right to cancel the NIB/Tender or to change qualifying requirement or to reject any or all the tenders so received without assigning any reason.
- 3.14. The Bidder whose Bid is accepted will be required to furnish by way of Performance Bank Guarantee the amount as prescribed in the NIB/Tender for the due fulfilment of this Contract.
- 3.15. Canvassing in connection with tenders is strictly prohibited and the tenders submitted by the Bidders who resort to canvassing will be liable to rejection straight way.
- 3.16. All rates shall be quoted on the proper form i.e. price bid supplied as part of the Tender documents on e-tender portal by the Department.
- 3.17. On acceptance of the Tender, the name of the authorized representative(s) of the Successful Bidder, who would be responsible for taking instructions from the Engineer-in-Charge and shall be communicated to the Engineer-in-Charge immediately after the allotment / start of work.
- 3.18. The JREDA does not bind itself to accept the lowest bid and reserves to itself the right to accept the whole or any part of the Tender and the Bidder shall be bound to perform the same at the rate quoted in this Tender.
- 3.19. No Bidder is permitted to Tender for the works if any of his near relatives is posted to deal with the Project activities and who is working in any capacity requiring him to give instructions / advice and in particular any office / official of the Company including the member of the Board. Any breach of this condition by anyone shall render him liable to be removed from the list of the contractors for the JREDA and the work entrusted to him may be terminated.

#### **4. Source of Funds**

The JREDA has decided to undertake the works *for Design, Engineering, Supply, Construction, Erection, Testing, Commissioning & Comprehensive Operation and Maintenance (for period of 25*

*Years) of 9 MW (AC) Ground Mounted Solar PV Power Plant on Identified Government Land at Palamu District of Jharkhand* “through funds available for development of solar power infrastructures in the state from Government of Jharkhand and to be implemented through JREDA. **Work order shall be issued as per the availability of fund or only after availability of fund from Government of Jharkhand.**

## **5. One Bid per Bidder**

Each Bidder shall submit only one Bid for one work. A Bidder who submits more than one Bid will be disqualified.

In exceptional circumstances, prior to the expiry of the original time limit, the JREDA may request to the bidders for an extension of the period of validity for a specified additional period. The request and the bidder’s responses shall be made in writing or by email. A bidder may refuse the request without forfeiting his Earnest Money. A bidder agreeing to the request will not be required or permitted to modify his bid but will be required to extend the validity of his earnest money for a period of the extension.

## **6. Description of Bid Process**

In order to identify Selected Bidder(s), JREDA shall follow a Bid Process comprising of a single-stage 2 (two) part (envelope) process, as explained below clauses.

## **7. Qualified Bidder**

Bidders are required to submit a Proposal consisting of 2 (two) parts (envelopes): (i) the Qualification Proposal/Technical Proposal; and (ii) the Financial Proposal as mentioned in ITB. The Qualification Proposal will be opened first. The determination of responsiveness of the Qualification Proposal and the evaluation of the Technical Capacity & Financial Capacity of the Bidder will be done in accordance with BDS Clause 2 PQRS. Bidders who meet the minimum technical requirements/Project experience requirements, Net Worth, Avg. Annual Turnover requirement (as per requirements mentioned in BDS Clause 2 PQRS) and whose Qualification Proposal is responsive shall be qualified for opening of their Financial Proposal (Qualified Bidders).

## **8. Financial Proposal**

JREDA shall open the Financial Proposals of only the Qualified Bidders to determine their responsiveness in accordance and to identify the Eligible Bidders in accordance. Lowest quoted bidder shall be declared as discovered lowest rate.

## **9. Clarifications on Bid Documents and Pre-Bid Meetings**

### **9.1. Clarifications and Queries**

- (a) If a Bidder requires any clarification on or has any query in relation to the Bid Documents, it should submit such query or request for clarification to JREDA in writing by e-mail [info@jreda.com](mailto:info@jreda.com). Alternatively, the Bidder can raise its queries during the Pre-Bid Meetings. All queries or clarification requests should be submitted on or before the date mentioned in the Bid Schedules specified in Bid information/details of bid in this tender.

- (b) JREDA shall make reasonable efforts to respond to the queries or requests for clarifications, on a non-attributed basis, on or before the date mentioned in the Bid Schedule/bid details sheet. However, JREDA reserves the right not to respond to any query or provide any clarification, in its sole discretion and in case of any discrepancy, the Bid Documents and the Project Agreements would prevail over the responses provided by JREDA. JREDA's responses (including an explanation of the query but not identification of its source) will be made available to all the Bidders in the manner set out in below Clause 9.1 (d) of this RFP.
- (c) JREDA may suo-motu, if deemed necessary, issue clarifications to all the Bidders.
- (d) JREDA shall respond to Bidder's queries/clarifications, through uploading the pre-bid query responses on the E-bidding Portal. While JREDA may choose to also communicate with the Bidders by e-mail, notice, or any other means it may deem fit, about the issuance of the clarifications, it is the Bidders responsibility to regularly visit the E-bidding Portal and keep itself updated regarding any Addendum, Corrigendum, clarification etc. that may be issued by JREDA.
- (e) Verbal clarifications and information given by JREDA or any other Person for or on its behalf shall not in any way or manner be binding on JREDA.

## **9.2.Pre-Bid Meetings**

- (a) All Bidders are invited to attend the Pre-Bid Meetings on the dates mentioned in the Bid Schedule/Bid details sheet in the Section 1 in the bid data sheet. The purpose of the Pre-Bid Meetings will be to clarify issues and answer questions on any matter relating to the Bid Documents, the Bid Process, Biding guideline, the solar specifications, procurement rules, Units and requirements of JREDA
- (b) All Bidders may nominate up to 3 (three) authorized representatives to participate in the Pre-Bid Meeting, by confirming their participation at least 3 (three) days prior to the Pre-Bid Meeting. Such confirmation shall be sent by e-mail to [info@jreda.com](mailto:info@jreda.com) .
- (c) All Bidders are requested to submit any queries to JREDA via email id [info@jreda.com](mailto:info@jreda.com) , at least 3 (three) days prior to the date of the Pre-Bid Meeting.
- (d) Notwithstanding above, during the Pre-Bid Meeting all Bidders will be free to seek clarifications and make suggestions to JREDA.
- (e) All questions raised (without identifying the source) and the responses given, together with any responses prepared after the Pre-Bid Meeting, will be uploaded on the E-bidding Portal and communicated to the Bidders through the 'Clarification to Tender Documents' feature on the E-bidding Portal, and may also be communicated to Bidders through e-mail, notice or any other means that JREDA may deem fit.
- (f) Non-attendance at the Pre-Bid Meeting will not be a cause for disqualification of any Bidder from participating in the Bid Process.

## **10. Amendment of Bid Documents**

### **10.1. Issuance of Addenda and Corrigenda**

- (a) Up until the date that is mentioned in the Bid Schedule/Bid details sheet in the Section 1, JREDA may, for any reason, whether at its own initiative or in response to a query raised or clarifications requested by a Bidder in writing or at the Pre-Bid Meeting, amend the Bid Documents by issuing an Addendum or revise the timelines of the RFP by issuing a Corrigendum.
- (b) All Addenda and Corrigenda will be provided on the E-bidding Portal.
- (c) The Bidders are required to read the Bid Documents along with any Addenda and Corrigenda that may be issued in accordance with this Clause-9.
- (d) Each Addendum/Corrigendum shall be binding on the Bidders, whether the Bidders convey or not their acceptance of the Addendum/Corrigendum.
- (e) Any oral statements made by JREDA or its advisors regarding the Bid Process, the Bid Documents or on any other matter, including oral clarifications or information provided by or on behalf of JREDA at the Pre-Bid Meeting or the minutes of the Pre-Bid Meeting shall not be considered as amending the Bid Documents.

### **10.2. Issuance of Revised Bid Documents and Project Agreements**

- (a) JREDA shall use reasonable endeavours to issue the revised Bid Documents reflecting all the amendments and changes agreed to by JREDA on or before the date that is mentioned in the Bid Schedule. The revised Bid Documents and Project Agreements issued by JREDA shall be definitive and binding.
- (b) JREDA will assume that the information contained in, or provisions of the revised Bid Documents will have been taken into account by the Bidder in its Bid. JREDA assumes no responsibility for the failure of a Bidder to submit the Bid in accordance with the terms of the revised Bid Documents or for any consequent losses suffered by the Bidder.

## **11. Preparation of Bids**

### **11.1. Language of the bid**

Language of the bid: The bid prepared by the bidder and all correspondences and documents relating to the bid, exchanged between the bidder and the Purchaser shall be written in the English language, provided that any printed literature furnished by the bidder may be written in another language so long as accompanied by an English translation of its pertinent passages. Failure to comply with this may disqualify a bid. For purposes of interpretation of the bid, the English translation shall govern.

## 11.2. Documents constituting the bid

The bid to be prepared and submitted by the bidder shall consist of the following documents:

SL No.	Qualification/Technical Bid (First Envelope): Online Submission only	
1.	Checklist for Technical Bid	As in section 6
2.	Covering Letter	Form-1
4.	Information about the bidding firm	Form-2
5.	Declaration by the bidder	Form-3
6.	Power of Attorney for Signing Bid	Form-4
7.	Format of Power of Attorney for Joint Venture/Consortium by lead member of JV/Consortium	Form-5
8.	Format for Consortium/Joint Venture Agreement	Form-6
9.	Letter of Intent By JV/Consortium Partners to Enter into Agreement/Form JV Or Consortium	Form-7
10.	Authorized Contact Person for the NIB	Form-8
11.	Format of No Deviation Certificate	Form-9
12.	Financial Capability Requirement: CA Certificate indicating average minimum annual turnover of during the last three financial years from FY 2020-21, FY 2021-22 & FY 2022-23	Form-10
13.	Financial Capability Requirement: CA Certificate for Net Worth As on 31 <sup>st</sup> March 2023	Form-11
14.	Annual Audited Balance Sheets, Profit & Loss Statement and ITR for FY 2020-21, FY 2021-22 & FY 2022-23	Standard
15.	Technical Capability Requirement: Details of Orders Received and Executed in Last Seven Years	Form-12
16.	Format of Details of Qualified Technical Staff	Form-13
17.	Format of Disclosure of PV Technology Proposed	Form-14
18.	Format of Declaration of Compliance	Form-15
19.	Declaration by the bidder towards non-Blacklisting/ Debars (on non-judicial stamp paper)	Standard
<b>Price Bid (Second Envelope): Online Submit only</b>		
20.	Duly Quoted & digitally signed Bill of Quantity (BOQ) in the file supplied by JREDA in. xls. ( <b>Price Bid part will not be submitted in technical Bid</b> ) <b>Price bid submitted with technical part shall be rejected by JREDA</b>	Format (Xls.) Provided along with this Bid document at Jharkhand tender site
21.	Format of Price Bid, Price Break-up of components, Price quote for O&M (To be submitted in.pdf file with price bid only. Do Not submit with Technical Part)	Annexure-1,2&3 ( Merge in a single PDF file)
<b>Other Documents ( Scan Copy for Online Upload)</b>		
22.	Original scan copy of online payments towards Tender fee	
23.	Original scan copy of online payments towards EMD	

24.	Firm's registration certificate company /Pvt. Ltd. / Proprietorship firm/Partnership/corporation/ LLP.
25.	Self-Attested Original scan copy of GST, PAN, PF and ESI certificates
26.	Valid Vendor registration certificate of JREDA
27.	Test Certificates of all components as per requirement

### **11.3. Sub-contractors**

Authorized dealer's companies/firm/corporation or subcontractors are not eligible to participate in this tender.

### **12. Bid Prices**

- 12.1.** The currency of the bid and currency of payment shall be in Indian Rupees. Foreign exchange component or foreign exchange variation will not be entertained for any reason whatsoever.
- 12.2.** The Contract shall be for the whole Works, as described in Section- 5 (SCC)
- 12.3.** The Bidder shall adopt the Item Rate Method as specified in the Notice Inviting Bid only the same option is allowed to all the Bidders.
- 12.4.** All duties, taxes, royalties, and other levies payable by the Contractor under the Contract, or for any other cause, shall be included in the rates, prices, and total Bid price submitted by the Bidder. The rates and prices quoted by the Bidder shall be fixed for the duration of the Contract and shall not be subject to adjustment.
- 12.5.** The bidders should quote their rates considering wide variation of site conditions, variation in price of different components during the year 2023-24 and keeping the quantum and quality of work in mind. If JREDA anticipates that rate is abnormally low or high, tender may be cancelled.
- 12.6.** The rates and prices quoted by the Bidder shall be fixed for the duration of the Contract.
- 12.7.** Quoted price for grid connected ground mounted SPV power plants are complete in all respect as per Technical Specifications including GST of all taxes & duties and royalties, packing, forwarding, transit insurance, loading & unloading, transportation & other charges etc. FOR destination at any site in Jharkhand and inclusive of installation, testing, commissioning, performance testing and training.

### **13. Bid Validity**

- 13.1.** Each Proposal shall be valid for a period not less than 180 (one hundred and eighty) days from the Proposal Due Date. The rate submitted by an Eligible Bidder shall be valid for a period not less than 180 (one hundred and eighty) days from the date of completion of the this bid process. A Bid valid for a shorter period shall be rejected as being non-responsive.
- 13.2.** In exceptional circumstances, prior to the expiration of the Bid validity period, JREDA may request Bidders to extend the Bid validity period. The request and the responses will be made in writing. An extension of the Bid validity period will not entitle a Bidder to modify its Bid.

### **14. Currencies of Bid and Payment**

The unit rates and the prices shall be quoted by the bidder entirely in Indian Rupees (INR).

## 15. Bid Security

### 15.1. Bid Security & Declaration

- (a) The Bidder shall furnish, as part of its Qualification Proposal, the online payment proof of the online submitted EMD as mentioned in the section-1 details of the bid. Bidder shall provide deposit bid security in online mode as per rules of e-tendering portal. A Standard Operating Procedure for online collection of Tender Fee and Earnest Money Deposit by Government of Jharkhand can be downloaded from [www.Jharkhandtenders.gov.in](http://www.Jharkhandtenders.gov.in) as a part of this tender document.
- (b) Provided that the Bidder is required to furnish only one Bid Security for the aforesaid amount while submitting its Proposal.
- (c) In case the Bidder fails to provide the Bid Security, the Proposal submitted by such Bidder shall be rejected by JREDA and will be considered as non-responsive. Unless invoked in accordance with relevant Clause of this RfP, the Bid Security of the unsuccessful Bidders shall be returned no later than thirty (30) days from the day of determination of the Selected Bidder in accordance with relevant clause of this RfP or any extended time agreed to by the Bidders as bid validity period or on occurrence of the annulment or cancellation of Bid Process by JREDA.
- (d) If the Bidder is declared as the Selected Bidder, then such Selected Bidder shall ensure that its Bid Security remains valid for a period until such Selected Bidder submits the performance bank guarantee(s), in accordance with the RFP and Project Agreements.
- (e) Bid Security of the Selected Bidder will be returned upon the Selected Bidder submitting the contract performance bank guarantee(s), in accordance with the RFP and Project Agreements.
- (f) The Bidder, by submitting its Bid pursuant to this RFP, shall be deemed to have acknowledged and confirmed that JREDA will suffer loss and damage on account of withdrawal of its Bid or for any default by the Bidder during the Bid validity period as set out in the Bid Schedule/Bid details sheet.
- (g) The Bid Security shall be invoked by JREDA without prejudice to any other right or remedy that may be available to JREDA hereunder or otherwise, under the following conditions:
- (i) if a Bidder engages in corrupt, fraudulent, coercive, or undesirable practice or restrictive practice as specified in relevant clause of this RFP.
- (ii) if, after the Proposal Due Date, a Bidder withdraws its Bid during the Bid validity period, as extended from time to time; and
- (iii) if a Bidder is selected as the Selected Bidder and it fails within the specified time limit to:
- sign and return, as acknowledgement, the duplicate copy of the LOA;
  - fulfil any other condition precedent to the execution of the Project Agreements/Contracts.

- execute all the Project Agreements/Contracts; or
- submit the requisite performance bank guarantee under the Project Agreements/Contract.

## **16. Submission of Bids**

For submission of the Qualification Proposal/technical Proposal and the Financial Proposal, the E-bidding Portal will provide, in which the Bidders will be required to submit their Proposals by providing the relevant information and uploading the relevant documents forming part of the Proposal.

**16.1. Technical Bid:** Technical bid shall comprise of the documents mentioned as per ITB clause no 11 ( preparation of bids) and technical bid shall be submitted online. Technical bid will open as per date and time of Technical Bid opening as per Section -3 (BDS) of NIB

**16.2. Financial Bid:** Financial bid shall be as per ITB clause no 8 and 11; Preparation of bid and complying Note Points mentioned in the Section -3 (BDS) of NIB, Financial Bids shall be as per specified in of ITB. All documents are to be signed digitally by the bidder.

## **17. Deadlines for Submission of Bids**

**17.1.** The bids must be submitted through e-tender mode not later than the date and time specified in the Bid Information Sheet in Section - I, Invitation for Bids (IFB).

**17.2.** JREDA may, in exceptional circumstances and at its discretion, extend the deadline for submission of Bids. In which case all rights and obligations of JREDA and the Bidders, previously subject to the original deadline will thereafter be subject to the deadline as extended. Notice for extension of bid submission date will be uploaded on e-proc website [www.jharkhandtenders.com](http://www.jharkhandtenders.com).

## **18. Late Bids**

**18.1.** Any bids received after the notified date and time as mentioned in the section-1 of closing of tenders will be treated as late bids and shall not be considered for further evaluation.

**18.2.** E-tendering system shall close immediately after the deadline for submission of bid and no bids can be submitted thereafter.

## **19. Modification and Withdrawal of Bids**

**19.1.** The bidder may withdraw or modify its bid after bid submission but before the due date and time for submission as per tender document with the due written consent from the authorized signatory of the bidder. The latest bid hence submitted shall be considered for evaluation and all other bids shall be unconditionally withdrawn.

## **20. Right to accept any bid and to reject any or all bids**

JREDA reserves the right to accept or reject any Bid, and to cancel the bidding process and reject all bids, at any time prior to the award of Contract, without thereby incurring any liability to the affected Bidder or bidders or any obligation to inform the affected Bidder or bidders of the grounds for the JREDA's action without any reason.

**20.1.** JREDA reserves the right to reject any Bid and appropriate the EMD if:

- a. after reviewing the Bid if there is any doubt that the offered works, materials or equipment are not state of the art and/ or not suitable for the site operating conditions;
  - b. at any time, a material misrepresentation is made or uncovered, or
  - c. the Bidder does not provide, within the time specified by the JREDA, the supplemental information sought by JREDA for evaluation of the Bid.
- 20.2.** Such misrepresentation/ improper response shall lead to the disqualification of the Bidder. If such disqualification / rejection occurs after the Bids have been opened and the Successful Bidder gets disqualified / rejected, then JREDA reserves the right to:
- a. select the next Bidder with the Lowest Evaluated Bid Value as the Successful Bidder;
  - <or >
  - b. take any such measure as may be deemed fit in the sole discretion of JREDA, including annulment of the bidding process.
- 20.3.** In case it is found during the evaluation or at any time before signing of the Contract or after its execution and during the period of subsistence thereof, that one or more of the pre-qualification conditions have not been met by the Bidder or the Bidder has made material misrepresentation or has given any materially incorrect or false information, the Bidder shall be disqualified forthwith, if not yet appointed as the Contractor either by issue of the LoI or entering into of the Contract Agreement, and if the Successful Bidder has already been issued the LoI or has entered into the Contract Agreement, as the case may be, the same shall, notwithstanding anything to the contrary contained therein or in this Tender, be liable to be terminated, by a communication in writing by JREDA to the Contractor, without JREDA being liable in any manner whatsoever to the Bidder or Contractor, as the case may be. In such an event, JREDA shall forfeit and appropriate the bank guarantees without prejudice to any other right or remedy that may be available to JREDA.
- 20.4.** JREDA reserves the right to verify all statements, information and documents submitted by the Bidder in response to the Tender Documents. Failure of JREDA to undertake such verification shall not relieve the Bidder of its obligations or liabilities hereunder nor will it affect any rights of JREDA there under.

## **21. Evaluation of Proposal**

### **21.1. Determination of Responsiveness of Qualification Proposals**

The minimum number of Qualified Bidders should be at least two for the Bid Process to proceed. If the number of Qualified Bidders is less than two, JREDA has the right to cancel the Bid Process and/or ask for fresh Bids to be submitted or to take any measure as it may deem fit including seeking approval from the Appropriate Commission.

JREDA will examine the Qualification Proposals to determine whether the Qualification Proposals are 'responsive' to the requirements of the RFP by checking:

- (a) whether they have been submitted by the Proposal Due Date;

- (b) whether they are complete and all documents comprising the Qualification Proposal have been submitted in their prescribed format;
  - (c) whether the documents have been properly signed;
  - (d) in case of a Consortium, whether the JBA has been signed by all Members;
  - (e) whether the power of attorney (if applicable) have been submitted; and
  - (f) whether the Qualification Proposals are generally in order including whether all documents have been submitted in the prescribed format.
  - (g) whether the Bid Security has been submitted in accordance with Saction-1.
- (a) In the event that any Bidder is found to be disqualified in accordance with the terms of the Bid Documents or if any Qualification Proposal is found to be non-responsive or not meeting the Technical and Financial Capacity, the Qualification Proposal will be rejected by JREDA and not be considered for further evaluation.
- (b) If any information furnished by a Bidder is found to be incomplete or contained in formats other than those specified in the RFP, JREDA may, in its sole discretion, exclude such information for the purposes of determining whether the Bidder will meet the Technical and Financial Capacity. Alternatively, JREDA may request the Bidder, from time to time while evaluating the Qualification Proposals, to submit necessary information or documentation, within a reasonable period, to rectify non-fulfilment related to documentation requirements. Such clarifications or information provided by the Bidder will be considered by JREDA while evaluating the Qualification Proposal, and it may qualify the Bidder on the basis of such clarifications or information provided, read along with its Qualification Proposal. If the Bidder does not provide clarifications sought within a specified period, its Qualification Proposal shall be considered as per bid submitted during online submission. If the Qualification Proposal is not rejected, JREDA may proceed to evaluate the Qualification Proposal by construing the particulars requiring the clarification to the best of its understanding, and the Bidder will be barred from subsequently questioning such interpretation of JREDA.
- (c) Where any information is found to be patently false or amounting to a material misrepresentation, JREDA reserves the right to reject the Bid and invoke the Bid Security in accordance with SCC Clause-6 .
- (d) Prior to the detailed evaluation, JREDA will determine the substantial responsiveness of each Bid. A substantially responsive Bid is one which conforms to all the terms and conditions of the Tender Documents without material deviations. Deviations from or objections or reservations to critical provisions such as those concerning EMD, Applicable Law and Taxes and Duties will be deemed to be a material deviation. JREDA's determination of a Bid's responsiveness is to be based on the contents of the Bid itself without recourse to extrinsic evidence.
- (e) Following factors shall be required for evaluation of Bid:
- The Evaluated Bid Value (EBV) shall be calculated using the following parameters and as mentioned in Annexure 11:

- Engineering Procurement Commissioning (EPC) Contract Price;
- Net Present Value (NPV) of O&M Price of Twenty-five (25) years;
- Net Electrical Energy Generation Guarantee; and
- Constant parameters as indicated in the Tender.
- The bidders for the plants will submit financials as per Annexure 1& 2, and the EPC and 25-year maintenance costs will be evaluated as per Annexure-3: Bid Evaluation Criteria (BEC) and will declare the successful bidder. The bidder with the lowest Evaluated Bid Value (EBV) for 09 MW will be considered L1. LOI shall be issued to L1 bidder.
- In no case, a Bidder shall have the right to claim to be the Successful Bidder for its Bid.

## **22. Criteria for Selecting bidder**

Subject to qualification requirements provided in Clause 2 of BDS, the JREDA will award the Contract to the Bidder whose Evaluated Bid Value is lowest.

## **23. Letter of Intent (“LOI”) and Notification to Proceed**

After selection of the Successful Bidder, a Letter of Intent (the “LoI”) shall be issued, in duplicate, to the Successful Bidder. The Successful Bidder shall not be entitled to seek any deviation from the Contract, as may have been amended by JREDA prior to the bid submission date.

## **24. Notification of Award and Issuance of LOA/WO**

After determination of the Selected Bidder, JREDA will issue the LOA/WO to the Selected Bidder in duplicate for the respective Unit/quantity/capacity. The Selected Bidder will, within 7 (seven) days of receipt of the LOA/WO or as informed by JREDA, sign and return, as acknowledgement, the duplicate copy of the LOA/WO. If the duplicate copy of the LOA/WO duly signed by the Selected Bidder is not received by the stipulated date, JREDA may, unless it consents to an extension, without prejudice to any of its rights under the Bid Documents or law, withdraw the LOA/WO and invoke the Bid Security of the Selected Bidder on account of failure of the Selected Bidder to acknowledge the LOA/WO and exercise one of the rights available to this RfP . Provided that where a Bidder is determined as the Selected Bidder and is issued the LOA/WO for said work, failure of the Selected Bidder to acknowledge the LOA/WO shall result in JREDA withdrawing the LOA/WO and invoking the entire Bid Security and exercise its rights available to it under the RFP.

## **25. Signing of Agreement**

**25.1.** Within 21 (Twenty) days of the release of Letter of Award of Award (LOA) by the JREDA, the successful Bidder/ Contractor shall be required to execute the 'Contract Agreement' with JREDA on a 'non-judicial stamp paper' of appropriate value [cost of the 'stamp-paper' shall be borne by the successful Bidder/ Contractor] and of 'state' specified in Bidding Data Sheet (BDS).

**25.2.** The Selected Bidder will execute the Project Agreements upon satisfying the following conditions:

- (a) sign and return, as acknowledgement, the duplicate copy of the LOA within 7 days of issuing the same;

(b) submit the Performance Guarantee / Security, in accordance with the provisions of the relevant Project Agreements during signing of the contract or within 21 days from issuance of LOA;

- 25.3.** The bidder whose Bid has been accepted will be notified of the award by the JREDA prior to expiration of the Bid validity period.
- 25.4.** The notification of award will constitute the formation of the Contract, subject only to the furnishing of a performance Guarantee/Security in accordance with the provisions of SCC Clause 6 & 7.
- 25.5.** The Agreement will incorporate tender document, Work order & subsequent amendments between JREDA and the successful Bidder. It will be signed by the JREDA and the successful Bidder after the security deposit is submitted.
- 25.6.** If the Selected Bidder fails to fulfil the above conditions, then JREDA may, unless it consents to an extension, without prejudice to any of its rights under the Bid Documents or law, withdraw the LOA/WO and invoke the Bid Security of the Selected Bidder on account of failure of the Selected Bidder to acknowledge the LOA/WO, and exercise one of the rights available in this RfP.
- 25.7.** Unless otherwise provided for in this RFP, the Selected Bidder will not be entitled to seek any deviation in the Project Agreements.

**26. Handing Over Asset**

After successful installation, commissioning, testing of complete system, the asset is to be handed over to JREDA. The handing over note covering the details of all the materials used and total work executed must be signed jointly by the Contractor/Developer and JREDA. The contractor shall have been solely responsible for any damage resulting from his operations up to the commissioning and handing over of the system. The contractor shall ensure provision of necessary safety equipment such as barriers, signboards, warning lights, alarms, etc. to provide adequate protection. Developer has to submit the Project completion report along with commissioning certificate to JREDA after completion of the project. Post completion of the project contractor have to submit all warranty, guarantee certificates to the JREDA.

## **SECTION-3: BID DATA SHEET & QUALIFICATION REQUIREMENTS (QR)**

**NIB No. 12/JREDA/SSP/PAL/2024-25**

**1. Bid Data Sheet**

S No.	Parameters	Bid Data Details										
1.	Scope of the Bid As per SCC clause 1	<p><b>Request for Proposal (RfP) for Design, Engineering, Procurement &amp; Supply, Construction, Commissioning and Comprehensive Operation &amp; Maintenance of cumulative 9 MW (AC) Grid connected Ground Mounted Solar PV Power Plant for a period of 25 years on Government Land at Palamu District of Jharkhand</b></p> <p><b>The Owner / Employer is:</b>                      Jharkhand Renewable Energy Development Agency (JREDA), 3rd Floor, SLDC Building, Kusai, Doranda, Ranchi 834502.                      Website:www.jreda.com Email:info@jreda.com</p>										
2.	Description of Bid Process	In order to identify Selected Bidder(s), JREDA shall follow a Bid Process comprising of a single-stage 2 (two) part (envelope) process, as explained below clauses.										
3.	Qualified Bidder	Bidders are required to submit a Proposal consisting of 2 (two) parts (envelopes): (i) the Qualification Proposal/Technical Proposal; and (ii) the Financial Proposal as mentioned in ITB. The Qualification Proposal will be opened first. The determination of responsiveness of the Qualification Proposal and the evaluation of the Technical Capacity & Financial Capacity of the Bidder will be done in accordance with ITB. Bidders who meet the minimum technical requirements/Project experience requirements, Net Worth, Avg. Annual Turnover requirement, and whose Qualification Proposal is responsive shall be qualified for opening of their Financial Proposal (Qualified Bidders).										
4.	Bid Capacity and Project Capacity/Quantity	The estimated total cumulative 9 MW (AC) capacity of the <b>Ground Mounted Solar PV power Plant</b> , to be developed Identified Government Land at Palamu District of Jharkhand as details mentioned below:										
5.	Project Location	<p><b>Project Location as mentioned below:</b></p> <table border="1" data-bbox="603 1518 1519 1982"> <thead> <tr> <th data-bbox="603 1518 802 1731">Locations</th> <th data-bbox="802 1518 914 1731">Land area in (Acre)</th> <th data-bbox="914 1518 1082 1731">Capacity of location in (MW)</th> <th data-bbox="1082 1518 1257 1731">Co-ordinates of Locations</th> <th data-bbox="1257 1518 1519 1731">Location of Evacuation of Power to JBVNL / JUSNL S/s</th> </tr> </thead> <tbody> <tr> <td data-bbox="603 1731 802 1982">Vill.: Parta, Block.: Haidarnagar, Dist.: Palamu</td> <td data-bbox="802 1731 914 1982">50</td> <td data-bbox="914 1731 1082 1982">09 MW</td> <td data-bbox="1082 1731 1257 1982">Latitude: 24.528066 1 Longitude: 83.920424 9</td> <td data-bbox="1257 1731 1519 1982">JBVNL, 33/11 KV Deori S/s @ Approx. 05 – 07 KM</td> </tr> </tbody> </table>	Locations	Land area in (Acre)	Capacity of location in (MW)	Co-ordinates of Locations	Location of Evacuation of Power to JBVNL / JUSNL S/s	Vill.: Parta, Block.: Haidarnagar, Dist.: Palamu	50	09 MW	Latitude: 24.528066 1 Longitude: 83.920424 9	JBVNL, 33/11 KV Deori S/s @ Approx. 05 – 07 KM
Locations	Land area in (Acre)	Capacity of location in (MW)	Co-ordinates of Locations	Location of Evacuation of Power to JBVNL / JUSNL S/s								
Vill.: Parta, Block.: Haidarnagar, Dist.: Palamu	50	09 MW	Latitude: 24.528066 1 Longitude: 83.920424 9	JBVNL, 33/11 KV Deori S/s @ Approx. 05 – 07 KM								

6.	<b>Evacuation of Power &amp; Metering Point</b>	Evacuation voltage shall be at 33 kV AC (three phase) wherein evacuating point cum metering point shall be installed at 33 kV bay in JBVNL's Power Substation Viz. Approx. 05 – 07 km away from the site. ABT Meter to measure net power evacuation shall be installed at 33 kV switchyard at generating end and at metering bay of JBVNL's Power Substation.						
7.	<b>Earnest Money Deposit (EMD) Amount (Refundable)</b>	<b>Rs. 1, 86,00,000/- (One Crore Eighty-Six Lakh Only)</b> (Through Online Via SBI Payment Gateway of Jharkhand Tenders) {This is mandatory}						
8.	<b>Commercial Operation Date (COD) &amp; Operational Acceptance Test (OAT)</b>	<b>Operational Acceptance Test (OAT)</b> shall be carried out by the developer in the presence of JREDA officials. The bidder must achieve the successful OAT before 30 days from date of ending of the contract period which is 12 months from issuance of LOA/WO. <b>COD:</b> The plant shall be fully operational within 30 days from the date of achieving successful Operational Acceptance Test (OAT). The Developer shall intimate JREDA at least 7 days before the OAT and COD.						
9.	<b>Security Deposit for Contract Period in form of BG/TDR/FDR/DD (As per SCC clause 6)</b>	The successful bidders shall submit the Contract security within 15 days of awarding work or LOA as mentioned in the below table. <table border="1" data-bbox="608 1128 1474 1639"> <thead> <tr> <th data-bbox="608 1128 858 1218"><b>Bidders</b></th> <th data-bbox="858 1128 1294 1218"><b>Deposit Validity</b></th> <th data-bbox="1294 1128 1474 1218"><b>Refund Timeline</b></th> </tr> </thead> <tbody> <tr> <td data-bbox="608 1218 858 1639">10 % of the Total Contract Value (INR)</td> <td data-bbox="858 1218 1294 1639">Minimum 1 Year or till successful achieving of Operational Acceptance Test or COD. (If contract period is extended due to delay in OAT/COD of the project, the bidder shall submit equal amount of Security Deposit for the extended period)</td> <td data-bbox="1294 1218 1474 1639">After 60 days from successful achieving the OAT and COD of the plant.</td> </tr> </tbody> </table>	<b>Bidders</b>	<b>Deposit Validity</b>	<b>Refund Timeline</b>	10 % of the Total Contract Value (INR)	Minimum 1 Year or till successful achieving of Operational Acceptance Test or COD. (If contract period is extended due to delay in OAT/COD of the project, the bidder shall submit equal amount of Security Deposit for the extended period)	After 60 days from successful achieving the OAT and COD of the plant.
<b>Bidders</b>	<b>Deposit Validity</b>	<b>Refund Timeline</b>						
10 % of the Total Contract Value (INR)	Minimum 1 Year or till successful achieving of Operational Acceptance Test or COD. (If contract period is extended due to delay in OAT/COD of the project, the bidder shall submit equal amount of Security Deposit for the extended period)	After 60 days from successful achieving the OAT and COD of the plant.						
10.	<b>O&amp;M Performance Security Deposit (25 Years O&amp;M service) in form of BG/TDR/FDR/DD (As per SCC clause 7)</b>	The successful bidders shall submit the performance Security within 30 days from COD as mentioned in the below table. <table border="1" data-bbox="628 1742 1485 2038"> <thead> <tr> <th data-bbox="628 1742 820 1872"><b>Bidders</b></th> <th data-bbox="820 1742 1139 1872"><b>Performance Security Deposit Validity</b></th> <th data-bbox="1139 1742 1485 1872"><b>Refund Timeline</b></th> </tr> </thead> <tbody> <tr> <td data-bbox="628 1872 820 2038">5 % of contract value (INR)</td> <td data-bbox="820 1872 1139 2038">Bidder shall submit Performance Security with minimum 5 years validity years) in each</td> <td data-bbox="1139 1872 1485 2038"><b>Every 5 Years</b> Performance Security Deposit shall be</td> </tr> </tbody> </table>	<b>Bidders</b>	<b>Performance Security Deposit Validity</b>	<b>Refund Timeline</b>	5 % of contract value (INR)	Bidder shall submit Performance Security with minimum 5 years validity years) in each	<b>Every 5 Years</b> Performance Security Deposit shall be
<b>Bidders</b>	<b>Performance Security Deposit Validity</b>	<b>Refund Timeline</b>						
5 % of contract value (INR)	Bidder shall submit Performance Security with minimum 5 years validity years) in each	<b>Every 5 Years</b> Performance Security Deposit shall be						

		<p>5 years till completion of entire 25 years.</p> <p>The bidder needs to submit new Performance Security at least before 45 days from expiry of existing Performance Security in every five years till 25 years.</p>	<p>refunded within 30 days from date of submission of new Performance Security Deposit upon expiry of existing BG Security in every 5 years.</p> <p>Performance security shall be released in 5 years basis subject to successful completion of the CMC in each year.</p>
		<p><b>Note:</b></p> <ul style="list-style-type: none"> <li>• Refund of the Performance security amount shall subject to successful completion of the CMC period every year and meeting the desired performance as per relevant clause of this rfp.</li> <li>• The minimum validity of the Performance Security Deposit shall be five (5) years and shall be renewed subsequently every five (5) years prior to Forty-Five (45) days of its expiry till 25 years.</li> <li>• BG/FD/DD shall be issued by scheduled commercial Bank.</li> <li>• <b>Rights to award Transfer/Award CMC work:</b> In case contractor/developer fails to comply with CMC requirements and meeting desired performance of the plant as per Work Order and RfP i.e. Fails to submit CMC report or meeting NEEGG or fails to attend/resolve complain after two notices issued by JREDA or two months whichever is earlier; 2<sup>nd</sup> part of the work order will be transferred to any of the technically qualified agency under that same NIB on quotation basis. The submitted performance bank guarantee of the agency will be forfeited along with necessary action as per prevailing rules.</li> </ul>	
11.	<b>Bid validity</b>	<b>180 days</b>	
12.	<b>Completion Period</b>	<b>12 Months</b>	
13.	<b>Eligible Bid Form</b>	<b>Bids from Consortium/ Joint Venture are ALLOWED</b>	
14.	<b>Number of Bids Per Bidder (as per ITB clause 5)</b>	Bidder shall submit only 'one [01] Bid' per bidder in the Bidding Process. A Bidder who submits or participates in more than 'one [01] Bid' will cause all the proposals in which the Bidder has participated to be disqualified. A Bidder including its Parent, Affiliate or Ultimate Parent or any Group Company may submit a single bid.	

## 2. Pre-Qualifying Requirements (PQRs)/ Eligibility Conditions

### 2.1.General Eligibility Conditions

<b>Nature of Bidding Entity</b>	<p>The bidders must fulfill the below requirement to participate in the bid process:</p> <ul style="list-style-type: none"><li>i Any registered company /Pvt. Ltd. / Proprietorship / firm/Partnership/corporation/LLP/Joint Venture/Consortium of not more than 03 (Three) companies. (Specific requirements for Joint Ventures/Consortium are given below) in India shall be eligible to submit the Bid.</li><li>ii Authorized dealer’s companies/firm/corporation, sub-contractors, NGO, Charitable trust, Educational Societies are not allowed to participate.</li><li>iii In case of registered Companies, the copies of Certificate of Incorporation (CoI), Article of Association (AoA), and Memorandum of Association (AoA) shall be provided along with the bid documents.</li><li>iv Bidders Shall not be declared ineligible/blacklisted/debarred for corrupt and fraudulent practices by the Central Government, any State Government or any public undertaking, autonomous body, authority by whatever name called under the works. The bidder shall submit a declaration on non-judicial stamp paper with appropriate value towards non-debarment/backlisted.</li></ul>
---------------------------------	--

## 2.2. Technical and Financial Eligibility Conditions

The Eligible bidder must fulfill the technical and financial requirements as eligibility mentioned in the below table.

Technical Capability	
<b>Project Experience Requirements</b>	<p><b>a) For General Bidders:</b></p> <p>I. The bidder shall have experience in the design, supply, installation, and commissioning of at least <b>1 (One)</b> Ground Mounted/Floating solar photovoltaic based grid connected power plant having an individual capacity of <b>7.5 MW or above (at Single Location)</b> in last 7 years (FY 2016-17 to FY 2022-23) with any State Govt. / Central Govt./ Govt. SNA/Govt. Autonomous Body/ Govt. Organization / Govt. Utility/ PSU. However, such Grid connected Solar PV Power Plant capacity must have been in satisfactory operation for at least one (01) year prior to the last date of bid submission.</p> <p style="text-align: center;"><b>Or</b></p> <p>II. The bidder shall have experience in the design, supply, installation, and commissioning of at least <b>2 (Two)</b> Ground Mounted/Floating solar photovoltaic based grid connected power plant having an individual capacity of each <b>4.5 MW or above (at Two Locations)</b> in last 7 years (FY 2016-17 to FY 2022-23) with any State Govt. / Central Govt./ Govt. SNA/Govt. Autonomous Body/ Govt. Organization / Govt. Utility/ PSU. However, such Grid connected Solar PV Power Plants capacity must have been in satisfactory operation for at least one (01) year prior to the last date of bid submission.</p> <p style="text-align: center;"><b>Or</b></p> <p>III. The bidder shall have experience in the design, supply, installation, and commissioning of at least <b>3 (Three)</b> Ground Mounted/Floating solar photovoltaic based grid connected power plant having an individual capacity of each <b>3.5 MW or above (at Multiple Locations)</b> in last 7 years (FY 2016-17 to FY 2022-23) with any State Govt. / Central Govt./ Govt. SNA/Govt. Autonomous Body/ Govt. Organization / Govt. Utility/ PSU. However, such Grid connected Solar PV Power Plants capacity must have been in satisfactory operation for at least one (01) year prior to the last date of bid submission.</p> <p>Note:</p> <ol style="list-style-type: none"> <li>The scan original copies of work orders and work completion certificates with O&amp;M report (last 12 months) issued by procuring authorities indicating its successful execution and performance certificate must be enclosed with Form-12).</li> </ol>

	<p>2. Work Experience with any Private firm/Private entity/ Private Developers shall be not accepted.</p>
<b>Financial Capability</b>	
<p><b>Turnover Requirements</b></p>	<p>a) <b>For General Bidder:</b> Average Annual financial turnover during the last 3 years, ending 31st March of the previous financial year, should be at least INR 27,89,10,000/- ( Twenty-Seven Crore Eighty Nine Lakh Ten Thousand only), derived from the last three financial years ending on 31.03.2023 on the basis of audited annual accounts.</p> <p>The certificate should be issued by CA who has performed audit of accounts with UID no. as per the Performa given in Form-10.</p>
<p><b>Net worth Requirement</b></p>	<p>Bidder should have Positive Net Worth upto 31-03-2023.</p> <p>Net worth certificate should be issued by CA with UID no. as per the Performa given at Form-11</p>

### 2.3. Joint Venture & Consortium Conditions

<p><b>Conditions for JV &amp; Consortium</b></p>	<p>In case the bid is submitted by a Joint venture (JV) or Consortium of two or more companies as partners, they must meet the following requirements: -</p> <ul style="list-style-type: none"> <li>a) The Lead partner of the JV/Consortium shall meet individually 100% of Technical Eligibility Conditions given at PQRS para above.</li> <li>b) There can be a maximum of 03 (Three) partners in a JV/Consortium.</li> <li>c) The Lead partner of the JV/Consortium shall meet individually not less than 50% of minimum Financial Eligibility Conditions for turn over requirements given at PQRS para above. However, all the JV/Consortium partners must meet collectively 100% Financial Eligibility Conditions for turn over requirements given at para above. Herein, apart from the Lead partner, a minimum of 25% Financial eligibility for turnover requirement should be met individually by all other partners of the JV/Consortium.</li> <li>d) The net worth of each Partner of JV/Consortium should be positive.</li> <li>e) In the case of a joint venture/Consortium, all members shall be jointly and severally liable for the execution of the entire Contract in accordance with the Contract terms. The JV/Consortium shall nominate the Lead partner of the JV/Consortium who shall have the authority to conduct all business for and on behalf of any and all the members of the JV/Consortium during the Bidding process and, in the event the JV/Consortium is awarded the Contract, during contract execution.</li> <li>f) A firm that is a Bidder (either individually or as a JV/Consortium member) shall not participate as a Bidder or as JV/Consortium member in more than one Bid. Such participation shall result in the disqualification of all Bids in which the firm is involved.</li> <li>g) Formation of JV/Consortium is not mandatory before bidding however a letter of intent ( as per format in Form-7) to execute an Agreement in the event of a successful Bid shall be signed by all members and submitted with the Bid, together with a copy of the proposed Agreement.</li> <li>h) The Bid Securing Declaration &amp; Performance Security (In case of award) of a JV/Consortium shall be in the name of the JV/Consortium that submits the Bid. If the JV/Consortium has not been legally constituted into a legally enforceable JV/Consortium at the time of bidding, the Bid Securing Declaration shall be in the names of all the members of the JV/Consortium &amp; not in the name of “only lead bidder”. The Bid Securing Declaration shall be executed in the names of all the members of the JV/Consortium.</li> </ul>
--	---

	<p>i) Similarly, in case of the award, the Performance Security and CMC Performance Security, to be submitted by a JV/Consortium shall be in the name of the JV/Consortium that has been awarded the LOA/Contract Agreement.</p> <p>j) In the case that the Bidder is a JV/Consortium, the Bid shall be signed by the authorized representative of the Lead partner of the JV/Consortium on behalf of the JV/Consortium and so as to be legally binding on all the partners as evidenced by a power of attorney signed by their legally authorized representatives as per Form-5.</p> <p>k) The joint venture/Consortium agreement should indicate precisely the responsibility of all partners of JV/Consortium in respect of planning, design, manufacturing, supply, installation, commissioning and training. All members of JV/Consortium should have active participation in execution during the currency of the Contract. The composition or the constitution of the JV/Consortium shall not be varied/modified subsequently without prior approval of the Employer/Owner.</p> <p>l) Joint Venture/Consortium must collectively satisfy the Criteria of below section-3,PQRS clauses 2.4 for which purpose, the relevant figure of the JV/Consortium shall be added together to arrive at total eligibility of the Joint Venture/Consortium.</p> <p>m) Joint Venture (JV), may or may not be incorporated as a Registered Company</p> <p>n) A Joint Venture (JV), if incorporated as a Registered Company, is required to submit Bid Securing Declaration and Performance Security (In case of award) in the name of Joint Venture only.</p> <p>o) A JV/Consortium is required to form JV/Consortium as per the agreement available in Form-6 for Consortium/Joint Venture Agreement.</p> <p>p) JV/ Consortium is also required to declare detailed scope of work to be executed by each partner of JV.</p>
--	---

**2.4. Technical & Financial Requirements for Individual Bidder And JV/Consortium**

Factor	Technical Requirements			
	Technical Criteria as per above clause 2.2			
Sub-Factor	Requirement	Bidder		
		Single Entity	Joint Venture/Consortium (existing or intended)	
			Each member	Lead Member

<b>Project Experience</b>	At least 1 (One) Ground Mounted/Floating solar photovoltaic based grid connected power plant having an individual capacity of each <b>7.5 MW</b> or above (at Single Location) in last 7 years	Must meet Requirements	NA	Lead member must meet 100% of the requirements
	At least 2 (Two) Ground Mounted/Floating solar photovoltaic based grid connected power plant having an individual capacity of each <b>4.5 MW</b> or above (at Two Locations) in last 7 years.	Must meet Requirements	NA	
	at least 3 (Three) Ground Mounted/Floating solar photovoltaic based grid connected power plant having an individual capacity of each <b>3.5 MW</b> or above (at Multiple Locations) in last 7 years	Must meet Requirements	NA	

Factor	Financial Requirement				
Sub-Factor	Criteria				
	Requirement	Single Entity	Bidder		
			Joint Venture/Consortium (existing or intended)		
			All members combined	Each member	At least one member/Lead
<b>Average Annual Turnover</b>	The average Annual turnover during last three years should be minimum 27, 90,00,000/- of the last three Financial year (i.e., FY 2020-21, 2021-22, 2022-23	Must meet Requirements	Must meet Requirements collectively	Must meet at least 25% of the requirement	Must meet at least than 50 % of the requirement
<b>Net Worth</b>	The net worth of each Partner of JV/Consortium should be positive	Must meet Requirements	The net worth of each Partner of JV/Consortium should be positive		

## **SECTION-4: GENERAL CONDITIONS OF CONTRACT (GCC)**

### **NIB No. 12/JREDA/SSP/PAL/2024-25**

#### **1. Introduction**

The instruction/information contained in the bid documents are for guidance and compliance of the intending bidder. Bidders are advised to obtain clarification from JREDA, if any, prior to submission of their bid, failing which it will be deemed that the stipulation made in the bid documents have been read, understood and are acceptable to the bidder.

Bidder shall bear all costs associated with the preparation and submission of the bid, journeys undertaken by them and subsequent bidding process till the award of the order to successful bidder

and the JREDA shall in no case, shall be responsible or liable for these costs, regardless of the conduct or outcome of the bidding process.

## **2. Bid Document**

Tender documents shall comprise of all the documents mentioned in this Bid. In addition to these any other documents/amendments/revisions or instructions issued by JREDA from time to time to bidders till due date of opening of the offers, shall also be deemed to be integral part of the bid document.

## **3. Inspection of the factory and Tests**

JREDA reserves the right to inspect manufacturer's works/factory to ascertain the capability/availability and quality of necessary equipment and infrastructure required for manufacture of the items offered. JREDA shall have the access and right to inspect the work or any part thereof at any stage and to test the goods to confirm their conformity to the technical specifications. Successful bidder shall inform JREDA at least 15 days in advance of schedule dispatch for technical sample audit. All the expenses for inspection in this regard shall be borne by the contractor only.

## **4. Dispatch Instructions**

Dispatch/Delivery of all items/equipment (s) /components shall be subject to Pre-Dispatch Inspection (PDI) by JREDA or its authorized representatives at the manufacturing site before their dispatch and delivery at site/location location/warehouse. The manufacturing site must have sufficient in-house testing facilities as per applicable IEC/IS/BIS standards. If the manufacturing site have not in house testing facility as per Standards, the manufacturer will arrange the testing of Selected samples at the MNRE approved Labs in the presence of JREDA or its authorized representatives. And the cost of Lab Testing shall be borne by the Manufacturer/Developer. The manufacturer will submit test report with regard conformity to technical specifications and details of materials in prescribed format for the items to be dispatched to work site of JREDA. However, equipment (s) will be dispatched from the manufacturing site only after the receipt of "Dispatch Clearance" from JREDA after acceptance of test report.

No consignment shall be dispatched without the receipt of dispatch clearance from JREDA. No PDI shall be done at any site other than the concerned manufacturing site or authorized sites of the manufactures. Successful bidders have to arrange necessary equipment (s) for testing the materials to be supplied during the pre-dispatch inspection by JREDA at their manufacturer's unit. Failure to fulfill the PDI conditions shall lead to cancellation of work order and forfeiture of security deposit. Supply, Installation & Commissioning for the above work must be completed in all respect within 60 days from the date of issue of the work order including Pre-Dispatch Inspection (PDI) of the materials. The contractor/vendor shall ensure the conduct PDI within 15 days of receiving official communication to JREDA regarding supply/ installation. The contractor shall intimate JREDA officially at least before 15 days before PDI. All the expenses for inspection in this regard shall be borne by the Bidder only.

## **5. Project Management Consultant and Third-Party Inspection Agency**

A Project Management Consultancy (PMC) or Third-Party Inspection agency (TPI) may be appointed by JREDA, at its sole discretion, to conduct any kind of inspection regarding procurement, fabrication, installation, hook-up, quality, execution, commissioning, operation and maintenance during the span of the Project. The Contractor shall provide necessary access and coordination to conduct such inspections. The Contractor shall provide all necessary access and cooperation for inspection by National or State agency.

## **6. Guarantee & Warranty**

The system for the project supplied, installed, and commissioned shall be guaranteed by the contractor for a minimum period of 5 (Five) years from the date of successfully commissioning of the system, in regard to quality of design, material, workmanship quality of process/ manufacturing, performance, efficiency, installation, etc. In the event any defect is found or developed in the system within the Guarantee period, shall be rectified by the contractor at his own expense promptly. The bidder shall submit the Warranty Certificates. The components Warranty certificate should be in the name of JREDA, Ranchi. Additionally, CMC services shall be provided for 25 years and bidder shall meet the minimum generation as per NEEGG.

## **7. Risk & Cost**

If the contractor/vendor fails to complete the awarded work from the scheduled date of completion then JREDA will be at liberty to cancel the said work order and will get the full or part of left over work to be completed by way of engaging alternate contractor and completion of the said work shall be got completed at risk & cost of the failed contractor and failed contractor shall be liable to pay all the dues to JREDA.

## **8. Arbitration**

All disputes arising out of or in connection with the present contract shall be finally settled under the Arbitration and conciliation Act 1996.

Further, SEAT of arbitration shall be "Ranchi". This RfP and all agreements related this work shall be governed by and construed in accordance with Laws of India. Any legal Proceedings in respect of any matters, claims or disputes arising out of or in connection with the RfP shall be under the jurisdiction of Court in Ranchi, Jharkhand as per applicable "Law".

## **9. Insurance**

The supplier/Contractor/Developer shall arrange for transit and erection insurance of the materials & equipment (s) for recommissioning of the solar plant. The supplier/Contractor/Developer shall also arrange for insurance of materials & equipment (s) up to CMC period. In case of any theft or damage of equipment during CMC period the same will be responsibility of supplier to get it rectified at their own cost.

The developer/Supplier/Contractor shall be liable for all statutory insurances of their workmen during the commissioning of the project and also during comprehensive maintenance period. Coverage provided is Indemnity against legal liability for accidents to employee under workmen's Compensation Act' 1923 and subsequent amendments of the said act prior to the date of issue of LOI and also under The Fatal Accidents Act' 1855 and Common Law of the land.

## **10. Assignment/ Sub-letting**

The vendor shall not assign or sublet, manufacture, shop testing, packing & forwarding, transportation, transit insurance, supply in whole or part, and its obligations to any third party to perform under the order/contract.

In the event the manufacturer contravenes this condition, JREDA reserves the right to reject the equipment/work contract and procure the same from elsewhere at manufacturer's risk and cost. The Manufacturer shall be solely liable for any loss or damage which JREDA may sustain in consequence or arising out of such replacing of the contract work.

## **11. Project Report**

The bidder shall submit the progress report fortnightly (15 day's) to JREDA. JREDA will have the right to depute their representatives to ascertain the progress of contract at the site.

## **12. Project Inspection**

**12.1.** The project progress will be monitored by JREDA, and the projects will be inspected for quality at any time during commissioning or after the completion of the project either by officer(s) from JREDA or any authorized agency/ experts. All the expenses for inspection in this regard shall be borne by the Bidder only.

**12.2.** JREDA reserves the right to do sample inspection checks for the projects commissioned by the Bidder.

**12.3.** JREDA may also depute a technical person(s) from its list of experts for inspection, third party verification, monitoring of system installed to oversee, the implementation as per required standards and also to visit the manufactures facilities to check the quality of products as well as to visit the system integrators to assess their technical capabilities as and when required.

## **13. Compliance with Regulations**

The supplier/contractor shall comply with all applicable laws or ordinances, codes approved standards, rules and regulations and shall procure all necessary municipal and/or other statutory bodies and government permits & licenses etc. at his own cost. The contractor shall leave the purchaser, Director, JREDA harmless because of any infractions thereof.

## **14. Income Tax**

Without prejudice to the obligations of the supplier under law, any income tax which JREDA may be required to deduct by law/statute, shall be deducted at source and shall be paid to income tax authorities on account of the supplier. JREDA shall provide the supplier a certificate for such deductions of tax.

## **15. Training Program, After Sales Service and Availability of Spare Parts**

**15.1.** The responsibility of organizing training program will rest on the successful bidder. The training program will be organized in consultation with JREDA/Consignee. The training program will focus on operation and maintenance of the system. Printed leaflet/literature should be made available in Hindi by the Supplier regarding the operation and maintenance of their Solar Power Plant.

**15.2.** The Supplier shall rectify the fault within 3 days from the Intimation of fault. Failure in rectification of the fault within 3 days from the intimation of fault will impose the penalty on the bidders as per the conditions mentioned in this tender at respective clauses, The supplier shall establish sufficient inventory of spares in the State in consultation with JREDA to provide satisfactory and uninterrupted services during the warrantee period.

#### **16. Corrupt or Fraudulent Practices**

The JREDA requires the bidders/Contractors to strictly observe the laws against fraud and corruption in force in India, namely, Prevention of Corruption Act, 1988. Also, if any of the documents submitted by bidder found out to be fake or incorrect in that JREDA has right to blacklist the company from future tenders and also cancel the work order.

#### **17. Indemnity**

The Empaneled Vendor agrees and have to submit the Bond along with contract to defend, indemnify and hold harmless JREDA, its officers, directors, consultant, agents, employees and affiliates (and their respective officers, directors, agents and employees) from and against any and all claims, liabilities, actions, demands, judgments, losses, costs, expenses, suits, actions and damages arising by reason of bodily injury, death or damage to property sustained by third parties that are caused by an act of negligence or the willful misconduct of the Empaneled Vendor, or by an officer, director, sub-Contractor, agent or employee of the Empaneled Vendor.

#### **18. Completeness of Tender**

All fittings, assemblies, accessories, hardware items etc. & safety and protection devices as required shall be deemed to have been included in the tender, whether such items are specifically mentioned in the BoM or not.

#### **19. Force Majeure conditions**

In the event of either party being rendered unable by force majeure to perform any obligation required to be performed by them under this agreement, relative obligation of the party affected by such force majeure shall be treated as suspended during which force majeure condition last.

The term force majeure shall have herein mean riots (other than among the contractor's employee), civil commotion, war (whether declared or not), invasion, act of foreign enemies' hostilities, rebellion, insurrection, military coup to usurp power, act of god such as earthquake, lightening, floods, fires not caused by contractor's negligence and other cause which the contractor has no control and accepted as such by the Director, JREDA, whose decision shall be final and binding.

If at any time during the continuance of the work the performance in whole or in part by either party of any obligation under this Contract, shall be prevented or delayed by reasons, of any war, hostility, acts of public enemy, Civil Commotion, sabotage, floods, explosion, epidemics, fires or other acts of God, strikes and lockout, (for which certificate of labor commissioner be produced) (hereinafter referred to as 'eventualities') then, provided notice of the happening of any such eventuality is given by either party to the other within 15 days from the date of occurrence thereof, neither party shall by reasons of such eventuality be entitled to terminate this Contract nor shall either party have any claim for damages against the other in respect of such non-performance or delay in performance and execution of work under this Contract shall be resumed as soon as practicable after such eventuality has cease.

If the work is suspended by force majeure conditions lasting for more than 45 days, the purchasers shall have the option of cancel this contract in whole or part thereof, at its discretion. The contractor shall not claim for compensation for force majeure conditions.

## **20. Confidential Information and Proprietary Data**

### **20.1. Proprietary Data**

All documents and other information provided by JREDA or submitted by a Bidder to JREDA will remain or become the property of JREDA, as the case may be. Bidders are required to treat all information provided by JREDA in the RFP and other Bid Documents as strictly confidential and not to use them for any purpose other than for preparation and submission of their Bids.

### **20.2. Confidentiality Obligations of JREDA**

JREDA will treat all information, submitted as part of a Bid as confidential and will require all those who have access to such material to treat it in confidence. JREDA may not divulge any such information or any information relating to the evaluation of the Bids or the Bid Process, unless:

- (a) such publication is contemplated under these Bid Documents; or
- (b) such publication or disclosure is made to any Person who is officially concerned with the Bid Process or is a retained professional advisor advising JREDA or the Bidder on matters arising out of or concerning the Bid Process; or
- (c) such publication is made for promoting the Solar Plant, including the names of Bidders that participated in the Bid Process and the rate quoted by them; or
- (d) it is directed to do so by any statutory authority that has the power under law to require its disclosure; or
- (e) such publication is to enforce or assert any right or privilege of the statutory authority and/or JREDA or as may be required by law (including under the Right to Information Act, 2005); or
- (f) in connection with any legal process.

## **21. Rights of JREDA**

**21.1.** JREDA, in its sole discretion and without incurring any obligation or liability, reserves the right, at any time, to:

- (a) suspend the Bid Process and/or amend and/or supplement the Bid Process or modify the dates or other terms and conditions relating thereto;
- (b) consult with any Bidder in order to receive clarification or further information, including information and evidence regarding its continued eligibility and compliance with the Financial Capacity requirement at any stage of the Bid Process;

- (c) retain any information, documents and/or evidence submitted to JREDA by and/or on behalf of any Bidder;
- (d) independently verify, disqualify, reject and/or accept any and all documents, information and/or evidence submitted by or on behalf of any Bidder;
- (e) reject a Bid, if:
  - (i) at any time, a material misrepresentation or incorrect or false information is made or uncovered;
  - (ii) the Bidder in question does not provide, within the time specified by JREDA, the supplemental information sought by JREDA for evaluation of the Bid; or
  - (iii) the Bid does not meet the validity requirement of the RFP;
- (f) accept or reject a Bid, annul the Bid Process and reject all Bids, at any time, without any liability or any obligation for such acceptance, rejection or annulment and without assigning any reasons whatsoever to any Person, including the Bidders. If JREDA annuls the Bid Process and rejects all Bids, it may, in its sole discretion, invite fresh Bids from all the Qualified Bidders.

**21.2.** If it is discovered during the Bid Process, at any time before signing the Project Agreements or after their execution and while they are in force that the Financial Capacity requirement has not been met by a Bidder or a Bidder has made misrepresentation or has given any incorrect or false information, then:

- (a) the Bidder shall be disqualified forthwith, if not declared as the Selected Bidder by the issuance of the LOA; or
- (b) the LOA shall be liable to be cancelled or the Project Agreements shall be liable to be terminated forthwith, if the Bidder has been declared as the Selected Bidder. JREDA shall not be liable in any manner whatsoever to the Bidder for such cancellation or termination.

In such an event, JREDA will have the right to invoke the Bid Security of such Bidder, and if after the execution of the Project Agreements the relevant counterparty(ies) to the Project Agreements shall have the right to forfeit and appropriate the performance bank guarantee, as a mutually agreed genuine pre-estimate of the loss suffered by JREDA or the relevant counterparty(ies) to the Project Agreements, as the case may be, for, amongst others, JREDA's or the relevant counterparty(ies) time, cost and efforts. Such forfeiture will be without prejudice to any other right or remedy that JREDA may have under the Bid Documents and the relevant counterparty(ies) to the Project Agreements may have under the respective the Project Agreements or applicable law.

## **22. Governing Law**

The Bid Process, the Bid Documents and the Bids shall be governed by, and construed in accordance with, the laws of India.

## **23. Jurisdiction of the Court**

All disputes would be settled within Ranchi jurisdiction of court of law only.

## **SECTION-5: SPECIAL CONDITIONS OF CONTRACT** **(SCC)**

**NIB No. 12/JREDA/SSP/PAL/2024-25**

**SPECIAL CONDITIONS OF CONTRACT (SCC)**

The following Special Conditions of Contract (SCC) shall supplement the General Conditions of Contract (GCC). Wherever there is a conflict, the provisions herein shall prevail over those in the GCC. The corresponding Clause number(s) of the GCC is/ are indicated in parentheses.

**1. Scope of work**

Request for Proposal (RfP) for Design, Engineering, Procurement & Supply, Construction, Commissioning and Comprehensive Operation & Maintenance of cumulative 9 MW (AC) Grid connected Ground Mounted Solar PV Power Plant for a period of 25 years on Government Land at Palamu District of Jharkhand.” is mentioned below.

Scope of Supply & Work includes design & engineering, procurement & supply of equipment and materials, testing at manufacturers works, multi – level inspections, packing and forwarding, supply, receipt, unloading and storage at site, associated civil works, services, permits, installation and incidentals, insurance at all stages, erection, testing and commissioning for 9 MW (AC) Solar PV Power Project, and performance demonstration with associated equipment and materials on turnkey basis along with 25 (Twenty five) years comprehensive operation and maintenance from the date of commissioning. The guaranteed plant performance in the form of guaranteed energy output as mentioned NEEGG. The project site location is as under:

<b>Locations</b>	<b>Land area in (Acre)</b>	<b>Capacity of the power plant to be developed (MW)</b>	<b>Co-ordinates of Locations</b>	<b>Respective JBVNL / JUSNL S/s with approximate distance from location.</b>
Vill.: Parta, Block.: Haidarnagar, Dist.: Palamu	50	09 MW	Latitude: 24.5280661 Longitude: 83.9204249	JBVNL, 33/11 KV Deori S/s @ Approx. 05 – 07 KM*

\*JREDA will co-ordinate with STU/state DISCOM for construction of transmission line to nearest Power Sub-station.

The details scope of work shall be as mentioned below.

**1.1. Preparation of Pre-feasibility Report (PFR) of the proposed site as mentioned above.**

**1.2. Planning, Designing and Engineering:**

- i. The Contractor shall plan and design for the structural/electrical / mechanical / civil requirements including but not limited to plant configuration, space optimization, distance between rows of modules, sufficient passage for vehicle and man-power movement in the plant, mounting structures, location of inverter room, cable routing, selection of equipment and items, procurement plan etc. to enhance plant output.

- ii. The Contractor shall prepare the detailed design basis report (DBR), PERT Chart (up to at least 3 levels) and Master Drawing List (MDL).
- iii. The contractor shall estimate the Plant Generation/Energy Yield based on Solar Radiation and other climatic conditions prevailing at site using the industry standard simulation software. Simulation report shall be submitted along with the design basis report. The data for the PV modules (drawings, GTP and PAN files) to be procured by the Owner shall be provided to the Contractor for this estimation.
- iv. The Contractor has to carry out the complete soil investigation of the site, through Government/NABL approved laboratory suggested by Owner/Client/Engineer-in-Charge before designing various civil structures. The design of all civil foundations, R.C.C structures, buildings etc. will be carried out considering appropriate seismic zone and wind zone of the area. All appropriate loads, wind velocity, seismic factors etc. will be considered as per the relevant IS Specifications while designing any civil structure. Also, the environmental conditions, soil characteristics, atmospheric effect, ground water table level, rain water data, land profile, etc. must be considered as per site actual condition and accordingly appropriate precautions and preventive measures shall be taken while designing the structures. RCC structures shall be adopted considering surrounding weather and soil conditions of site and as per the relevant IS codes. The concrete mix design test shall be carried out in Govt. certified laboratory or NABL Accredited laboratory for minimum M20 grade with 350 kilograms of cement.
- v. Design of associated civil, structural, electrical & mechanical auxiliary systems includes preparation of single line diagrams and installation drawings, manuals, electrical layouts, erection key diagrams, electrical and physical clearance diagrams, design calculations for Earth- mat, Bus Bar & Spacers indoor and outdoor lighting/ illumination etc., GTP and GA drawings for the major equipment including transmission line, design basis & calculation sheets, and other relevant drawings and documents required for engineering of all facilities within the periphery to be provided under this contract.
- vi. All drawings shall be fully corrected to match with the actual "As – Built" site conditions and submitted to Employer after commissioning of the project for record purpose. All as-built drawings must include the Good for Construction deviation list.
- vii. The Contractor shall take into consideration all parameters like wind speed, seismic zone, safety factor and safe Soil Bearing Capacity (SBC) etc. for the purpose design and construction of civil foundations for all civil work as per relevant IS codes.
- viii. The Contractor shall carryout Shadow Analysis at the site and accordingly design strings and arrays layout considering optimal usage of space, material and labour.
- ix. All designs & drawings have to be developed based on the governing standards and requirements of the project and also keeping in mind basic design specifications. Company may approve minor deviations or suggest required modifications in the same

which are meant for increasing plant performance without sacrificing quality / workmanship norms.

- x. The Contractor at their own cost has to send samples of the material to Govt. accredited / NABL accredited laboratory for testing as when required/instructed by EIC of the Company.
- xi. The Contractor/Developers may modify the specifications at any stage as per local site conditions/ requirements and EPC contractor shall comply with modification without any extra cost and time. However the contractor shall be needed prior approval of JREDA before making any changes to the overall plant specifications.**
- xii. The contractor shall submit basic design data, design documents, drawings and engineering information including GTP and test reports to Employer or its authorized representative for review and approval from time to time as per project schedule. The documents typically include, but not limited to, the following:
  - Detailed and Plant Level Equivalent PSS/E Model of the SPV Plant to demonstrate performance under steady-state and dynamic state at the Point of Interconnection in accordance with requirements for connectivity under Regulations notified by CERC and JSERC time to time.
  - The Contractor shall also submit a study report analysing the response of the plant in case of transients (HVRT, LVRT, VAR injection & absorption, etc
  - Detailed technical specifications (GTP) of all the equipment
  - General arrangement and assembly drawings of all major equipment
  - Schematic diagram for entire electrical system (DC, AC and auxiliary systems)
  - GTP & G.A. drawings for all types of components 33 kV switchgears (as applicable) & other interfacing panels
  - Test reports (for type, routine and acceptance tests)
  - Relay setting charts
  - Design calculations and sheets (civil, mechanical, structural and electrical designs)
  - Geo technical investigation data and Topographical survey report including topographical survey data in digital format (Excel file) and Contour plan of the area.
  - GA drawings of the entire project including equipment rooms/ inverter control rooms, office cum control room, roads, storm water drainage, sewage networks, GA drawings of the entire project including equipment rooms/ inverter control rooms, office cum control room, roads, storm water drainage, sewage networks, security gate, fire protection system, perimeter fencing, transformer yard fencing etc.
  - Switchyard drawings and erection plans as per DISCOM / STU / CTU guidelines.
  - Quality assurance plans for manufacturing (MQP), Standard Operating procedure (SOP) and field activities (FQP)
  - Detailed site EHS plan, fire safety & evacuation plan and disaster management plan.
  - O&M Instruction's and maintenance manuals for major equipment
  - As-built drawings / documents and deviation list from good for construction (GFC)

xiii. Approval of Designs / Drawings: The following procedure has to be followed for assessment and approval of designs, specifications and drawings during the course of the project:

- The Contractor shall submit to the Company/Consultant the documents in hard copy and soft copy to both with proper reference and drawing numbers.
- The respective documents for selection, supply, installation, erection, commissioning of equipment/ structures have to be submitted at least 15 days in advance to the planned start of the activity as per Contractor's project schedule.
- The Contractor shall submit documents as required for this project according to his design and specifications. The Company / Consultant (on behalf of the Company) will assess and approve the documents/drawings/designs/GA & GTP/Credentials within 10 days from the date of submission of such documents; and only after the approval the Contractor shall release the documents on site for execution.
- The documents shall be revised by the Contractor as per instructions /comments given by the Company / Consultant (on behalf of the Company) if required, prior to execution. Review time for comments/approval by Company for Subsequent revisions shall be within 10 days from date of submission of revised drawing/design/GTP/Credential.
- The Final Approval version of the documents shall be submitted in hard and soft copy to the Company and the Consultant. The Contractor has to take into account the above mentioned process of revisions (if required) and adjust the preparation and delivery of the documents such that the overall planned project schedule is not affected. Any extension on account of approval process shall not be entertained.
- All components of the Solar PV Power Plant shall be in accordance with Technical Specifications given in relevant IS/ IEC Standards. The design and commissioning shall be as per latest IS/ IEC standards. The following are some of the technical measures required to ensure quality of the major components used in grid connected solar power Projects.

### **1.3. Procurement and Supply**

- i. Supply of Solar PV Modules, Inverters, Cables, Transformers, Module mounting structures, Electrical Panels, Switch gears, structures, Protection system, SCADA system, Safety system, security system, meters, Connectors and any other components required for commissioning of the plant is in the scope of the EPC Contractor.
- ii. Contractor shall supply all the necessary equipment, materials for construction of substations, boundary walls, foundation work, Transformer Bay and any other civil work/ construction work required for completion of the project.
- iii. It shall be the responsibility of the Contractor to supply complete capacity of PV Modules at Project site, between 2 (two) to 3 (three) months from date of award of the Contract. The EPC Contractor shall consider PV Modules of 540 Wp power

rating and minimum efficiency of 21% for the scope of works as per the specifications provided in this document.

- iv. Transportation, Unloading and Storage of Solar PV Modules as per Module Manufacturer's recommendations is in the scope of the EPC Contractor.
- v. Any civil works required for preparing the storage facility is in the scope of the EPC Contractor. The Contractor shall satisfy themselves of the quality of the unloaded PV Modules before storage. Unpacking of pallets, Inspection and Re-packing of PV Modules are in the scope of the EPC Contractor. Any damage to the PV Modules after taking over by EPC Contractor shall be responsibility of the EPC Contractor. The EPC Contractor shall obtain necessary insurance cover for the same. The insurance cover shall be effective from the date of delivery of the modules at site.
- vi. Module Mounting Structure (MMS) with necessary hardware suitable for mounting PV Modules.
- vii. In case solar cables are connected to DC cable via Insulation Piercing Connector (IPC), instead of SCB, String Isolation Box (SIB) along with mounting structure shall be provided.
- viii. Solar Cables of appropriate size and rating from PV Modules to SCB / IPC / String Inverter along with straight/Y-connectors/branch connectors, ferrules, conduits, cable ties and other materials required for cable laying and termination at both the ends. Power Conditioning Units (Central / String Inverter) of appropriate rating. DC Cables of appropriate size and rating from IPC to SIB (in case IPC is used) along with cable termination kits, ferrules / tags, conduits, cable ties and other materials required for cable laying and termination at both the ends.
- ix. AC Combiner Box / LT Switchgear panel of appropriate rating with adequate number of inputs for pooling of power from String Inverter to Inverter transformer.
- x. AC Cables (LT & HT) of appropriate size and rating along with cable termination kits, ferrules / tags, conduits, cable ties and other materials required for cable laying and termination at both the ends.
- xi. Inverter transformers of appropriate rating including fire protection system. 33 kV Switchgear Panels / 33KV outdoor yard including Vacuum / SF6 Circuit Breakers, Current Transformers, Voltage Transformers, Relays and other accessories for complete protection at the inverter stations. In case 33Kv Switchgear panels are used, the same shall be placed on elevated platform with overhead canopy.
- xii. Any other equipment / system required to comply with the relevant Procedures / Regulations issued by CEA/ CERC/ any other statutory body for connectivity to the Grid.

- xiii. The Contractor shall provide provision to integrate Special Protection Scheme (SPS), if required, in case the RLDC requires the same. In that event, details of SPS and its setting shall be worked out in consultation with RLDC & RPC.
- xiv. Fibre Optic based communication system comprising of OPGW cable (having minimum 12 fibres) and hardware fittings for the transmission line and FOTE (STM16) terminal equipment, FODP, approach cables and other associated equipment/accessories at Solar Plant Pooling Substation and interconnecting substation as per CTU specifications. The communication system shall facilitate for telemetry data communication, voice communication and tele-protection
- xv. Uninterrupted Power Supply (UPS) including Batteries, Distribution Boards, Cables and associated equipment. Battery Bank, Battery Charger, Distribution Boards, Cables and associated equipment. LT Power and Control Cables including end terminations and other required accessories.
- xvi. Communication cables including end terminations and other required accessories. Supervisory Control and Data Acquisition (SCADA) and Power Plant Controller (PPC) for remote monitoring/control of plant facilities.
- xvii. Data Acquisition System and communication infrastructure to transfer real time data to SLDC / RLDC.
- xviii. Earthing system including earth strip/cables, earth electrodes, earth enhancing compound and all other associated materials for complete earthing of the plant. Lightning Protection System for entire plant area. LED luminaries with diffuser for illumination, lighting poles, distribution boxes and power supply cables along with required conduits, fittings, etc
- xix. CCTV cameras with monitoring station along with mounting poles, power supply cables, communication cables, network switches, conduits, fittings, etc. ,
- xx. Fire detection and fire protection system in buildings/containers, inverter / transformer yard and switchyard.
- xxi. Testing instruments as specified. Mandatory spares as specified. Supply of site office (Portable Cabin type) for Owner during construction.
- xxii. Any other equipment / material not mentioned but required to complete the Solar Power Plant facilities in all respect.
- xxiii. **Weather Monitoring system:** Weather Monitoring Station shall include but not be limited to the following:
  - Pyranometers - for Horizontal and Tilted Plane
  - Ultrasonic Anemometer (Wind Speed and Direction)
  - Temperature Sensor - Ambient and Module Surface
  - Power Source to the all Sensors

- Data Logger
- Any other equipment/ material, not mentioned but required to complete the Solar Power Plant facilities in all respect.

#### **1.4. Installation, testing and commissioning:**

##### **i. Module Mounting Structures (MMS):**

- The Contractor shall design, fabricate, supply and install module mounting structures with all required accessories like clamps, nuts, bolts, cable ties etc., The structures can be of fixed/ seasonal tracker are accepted.
- Modules shall be mounted on a non-corrosive support structure (EPDM rubber gasket /Stainless Steel Star Washer). The frames and leg assemblies of the array structures shall be made of hot dip Galvanized steel as per ASTM A123 (Column Post, Purlin, Rafter, Bracing etc). Galvanisation thickness shall not be less than 80 microns. If Galvalume is proposed by contractor, then minimum thickness of any member shall not be less than 1.2 mm thickness irrespective of design calculation (Min thickness shall not be less than 1.2 mm in any case). Material grade shall be as per IS:2062-2011 & BIS 15961-2012, HDG Steel. All nuts and bolts (fasteners) shall be made very good quality stainless steel of grade SS 304 required for module fixing and for other components of MMS, superstructure or switchyard, inverter room, control room, etc. in the plant premises the nuts and bolts (fasteners) shall be of Galvanised MS material with minimum Grade HDG: 5.6.

##### **ii. Civil Works:**

- The Contractor shall design and construct appropriate civil foundations for MMS, prefabricated structures/RCC, transformers, switchyard equipment, feeder bay etc.
- The following prefabricated are to be planned and constructed by the Contractor Solar PV project locations
- Prefabricated/engineered / RCC Inverter rooms.
- Prefabricated/Pre-engineered Control room Cum Conference room with Conference Room, Office Room, SCADA monitoring room, Store room, Control Room, Toilet units for ladies and Gents, Passage and Pantry unit.
- Pre-fabricated/engineered Watchman's cabin - 04 Nos.
- Security: Security cabin shall be provided at the entry of each pocket (i.e. if utilized for installing Solar PV Project) of project site.
- Chain-Link Fencing and Boundary Wall: The Contractor shall provide chain-link fencing of the entire plant boundary for the plant sites.

- Roads: The Contractor shall provide Road (Internal and Approach) of Water Bound Macadam type for both plant site with proper access for cleaning of the modules.
- Main Gate: The Contractor shall provide main gate of structural steel material of appropriate design at the entry of both plant sites. Also, necessary arrangement has to be made by Contractor to erect the main gate on pylon stone.
- Site levelling: The Contractor shall level the site if required, so as to compact the plant in minimum possible area and also minimize shading losses because of solar PV module structures. Removal of debris and bush-cutting is mandatory.
- Any other necessary civil works required for completion of the project shall be done by the contractor within due timeline.

**iii. Electrical Work/Installations:** Consisting of installation of solar PV modules, grid-tied String inverters, Inverter Duty Transformers, meters, control panel, 33 kV switchgear for evacuation. interconnection through wires, cables, bus bars, etc.; plant lighting system, automatic weather station, SCADA and remote web-based communication & monitoring hardware, software etc.; plant and human safety and protection equipment including danger signs etc. but not limited to following:

- Installation of PV Modules on Module Mounting Structure and interconnection of PV Modules.
- Installation, Testing and Commissioning of String Combiner Box / String Isolation Box in case of Central Inverter configuration.
- Installation, Testing and Commissioning of Power Conditioning Units String Inverter). Laying of Solar cables from PV Modules to String inverter / IPC along with
- Installation of PV Modules on Module Mounting Structure and interconnection of PV Modules. Installation, Testing and Commissioning of String Combiner Box.
- Installation, Testing and Commissioning of Power Conditioning Units. Laying of Solar cables from PV Modules to SCB / String inverter / IPC along with
- Installation, Testing and Commissioning of Telemetry System for communication of Plant Data to SLDC / RLDC. Earthing of PV Modules, Module Mounting Structures, PCU, Switchgear panels, Transformers, and all other electrical equipment. Installation of lightning protection system for entire plant facilities.
- Installation of illumination system including all required accessories and laying of power supply cables. Installation, Testing and Commissioning of Weather Monitoring Station along with laying of required power supply and communication cables.
- Installation of CCTV cameras on strategic locations including all required accessories, laying of power/communication cables and installation of monitoring

- station. Installation of fire detection and fire protection system for buildings/containers, transformer yard and switchyard.
- Pre-commissioning checks and tests for all equipment. Synchronization and Commissioning of plant.
  - Any other works related to installation, testing and commissioning not mentioned but required to complete the Solar Power Plant facilities in all respect.
- iv. Evacuation of Power & Metering Point:** For this project, the evacuation voltage shall be at 33 kV AC (three phase) wherein evacuating point cum metering point shall be installed at 33 kV bay in JBVNL's Power Substation Viz. Approx. 05 – 07 km away from the site. ABT Meter to measure net power evacuation shall be installed at 33 kV switchyard at generating end and at metering bay of JBVNL's Power Substation.
- v. Solar PV Module Cleaning System:** Cleaning frequency shall be decided by the Bidder to meet the guaranteed generation. For this, the Contractor shall construct and operate 2500 litre /MW capacity readily available HDPE water storage tank. The Contractor also has to drill a bore for catering water demand and construct pipeline network for carrying water to storage tank, Water tank to PV array yard, provide electric panel and pump for bore & total water cleaning system (One standby pump). For module cleaning, the contractor can provide new tanker with pump; water jet and hose pipe or establish a pipeline network with valves. Bidder may also consider Robotic/dry Cleaning.
- vi. Cable Trenches:** Construction of RCC cable trenches with cable trays and covers in inverter and control rooms, and for PV array Yard/Field earthen excavated cable trench with alternate layers of sand and brick as per relevant IS from PV arrays to inverter room to control room to switchyard shall be provided by the Contractor. Contractor can also propose elevated structural cable tray.
- vii. Communication system:** The Contractor shall provide complete plant SCADA with SCADA server having string level monitoring capabilities over remote server. Contractor shall lay the cable in appropriate cable trench, connect with suitable connectors and terminate to the SCADA server inside control room. The Contractor shall also provide necessary internet connection through GPRS enabled modem along with LAN connectivity for data communication over remote server and shall bear the cost of the same during the Contract period including O&M. The Contractor shall provide necessary provision of RTU for communication with SLDC. The Contractor shall submit the below mentioned Technical Data Sheet for String RTU, TCP String, Central RTU in the prescribed format. Internet connection shall be in the name of JREDA. However, all the charges to be paid by the Contractor during the O&M period including the initial one time cost. Plant monitoring shall be done through SCADA place in the control rooms of each plot, JREDA shall decide to designate one control room as a master control room for monitoring/ controlling and access of all other plants.

**viii. Plant Safety Equipment:** The Contractor shall provide appropriate numbers of foam type fire extinguishers / CO2 extinguishers, sand buckets and transformer discharge rod at Inverter Rooms, Control Room, Security Cabin and Switchyard/Substation. Further, all high voltage places to be provided with danger sign boards with appropriate size and material to last for 25 years.

#### **1.5. Statutory Requirements:**

- All construction, operation and maintenance procedures shall be carried out through appropriate relevant standards, regulations laid by JREDA / JUVNL / JUUNL / JBVNL / MNRE and / or any other agency as and when applicable. Further, this shall comply with the applicable labour laws. The Bidder shall make himself aware of such requirements and shall not solely depend on the Company to avail full information.
- Obtaining statutory approvals /clearances/ compliances on behalf of the Employer from various Departments, not limited to, the following:
  - Pollution control board clearance, if required
  - Mining Department, if required
  - Forest Department, if required
  - All other approval as and when, as necessary for setting up of the solar power plant including CEIG/ CEA, power evacuation, etc. as per the suggested guidelines.
- All royalties and taxes as required to be paid for excavation of earth / rocks / sand shall be borne by the Contractor.
- All other statutory approvals and permissions and their respective compliances, not mentioned specifically but are required to carry out hassle free Construction and O&M of the plant.
- Adequate and seamless insurance coverage during EPC and O&M period to mitigate all risks related to construction and O&M of the plant to indemnify the Employer.

#### **1.6. Final Commissioning**

The commissioning procedure shall be as per JREDA/ JUVNL/ JBVNL/ Chief Electrical Inspector to Government (CEIG) requirements. The Contractor shall also ensure the following:

- i. Pre-commissioning checks and tests for all equipment.
- ii. Synchronization and Commissioning of plant to the grid.
- iii. Successful achieving of Operational Acceptance Test (OAT) presence of JREDA officials and completion certificate issue by JREDA upon completion of OAT
- iv. Obtaining written certificate of commissioning of the facility and permission to connect to the grid from the office of the Chief Electrical Inspector of the state

and any other authorized representative from Government of India (GoI)/ GoJ/ JBVNL.

- v. Inspection and successful electrical commissioning certificate from the Company.
- vi. Obtaining all certificates required by JBVNL from agency appointed by them.
- vii. Satisfactory completion certificate towards completion of all other contractual obligations by the Contractor as stipulated from the Company.

**1.7. Operation and Maintenance (O&M):** The scope of work includes Operation and Maintenance (O&M) of the plant for twenty-five (25) years, wherein the plant shall generate at least equivalent to the guaranteed Performance of Plant as per NEEGG. The Bidder shall submit in the Bid a comprehensive project execution schedule as well as Operation and Maintenance (O&M) schedule with resource planning in the form of Gantt chart and shall be liable for abiding by the schedule. It is the responsibility of the Contractor to perform the necessary maintenance/ timely replacement of all Civil /Mechanical or Electrical components of the project during this O&M period such that the guaranteed performance of the plant is not compromised. Any damage to CIVIL/ ELECTRICAL/ MECHANICAL components of the plant is to be reworked/ replaced/ supplied without any extra cost and time by the Contractor during complete O&M period. The Operation and Maintenance shall be comprehensive. The maintenance service provided shall ensure project functioning of the Solar PV system as a whole and Power Evacuation System to the extent covered in the Contract. All preventive/ routine maintenance and breakdown/ corrective maintenance required for ensuring maximum uptime shall have to be provided. Accordingly, the Comprehensive Operation and Maintenance shall have two distinct components as described below:

- i. **Preventive / Routine Maintenance:** This shall be done by the Contractor regularly and shall include activities such as cleaning and checking the health of the Plant, cleaning of module surface, tightening of all electrical connections, and any other activity that may be required for proper functioning of the Plant as a whole. Necessary maintenance activities, preventive and routine for Transformers and associated switchgears also shall be included.
- ii. **Breakdown/ Corrective Maintenance:** Whenever a fault has occurred, the Contractor has to attend to rectify the fault, the fault must be rectified within 24 hrs time from the time of occurrence of fault failing which the Contractor will be penalized as per terms and conditions of this Tender.
- iii. The date of Comprehensive Operation and Maintenance Contract period of the Plant shall begin on the date as defined in the NIB of this Tender. Detailed scope of comprehensive operation & maintenance has been described in Chapter 5 of this document. However, operation of the Power Plant means operation of system as per bidding schedule and workmanship in order to keep the project trouble free covering the guarantee period.

- iv. To provide a detailed training plan for all O&M procedures to Employer's nominated staff, which shall have prior approval from the Employer.
- v. Employ and coordinate the training of contractors' personnel who will be qualified and experienced to operate and monitor the facility and to coordinate operations of the facility with the grid system.
- vi. To maintain accurate and up-to-date operating logs, records and monthly Operation & Maintenance reports at the facility. Contractor shall keep the measured daily data at regular intervals and provide the same to Employer in electronic form, compatible in CSV format. The right to use the data shall remain with the Employer.
- vii. Procurement of spare parts, overhaul parts, tools & tackles, equipment, consumables, etc. required for smooth operation and maintenance of the plant as per prudent/ standard utility practices, OEM recommendations and warranty clauses for the entire O&M period
- viii. To upkeep all administrative offices, roads, tool room, stores room, equipment in clean, green and workable conditions.
- ix. To carry out periodic overhauls or maintenance required as per the recommendations of the original equipment manufacturer (OEM) and to furnish all such periodic maintenance schedules at the time of plant commissioning/ start of O&M contract.
- x. Handover the system to maintain an inventory of spare parts, tools, equipment, consumables and supplies for the facility's operation along-with required details of recommended spares list with all associated information regarding replacement records, supplier details, tentative cost, storage details, specifications on the basis of replacement frequency and mean time between failures and mean time to restore at the culmination of penultimate year under O&M period.
- xi. Continuous monitoring the performance of the Solar Power Plant and regular maintenance of the whole system including Modules, PCU's, transformers, overhead line, outdoor/indoor panels/ kiosks etc. are necessary for extracting and maintaining the maximum energy output from the Solar Power Plant.
- xii. The period of Operation and Maintenance will be deemed to commence from the date of commissioning and successively the complete Solar Photovoltaic Power Plant to be handed over to the O&M contractor for operation and maintenance of the same. O&M contract shall further be extended on the mutually agreed terms and conditions for the mutually agreed period.
- xiii. The Contractor shall ensure that all safety measures are taken at the site to avoid accidents to his or his sub-contractor or Employer's Workmen. This will include procurement of all safety gadgets during Construction and O&M period including

but not limited to, rubber mats of appropriate grade, PPE, rubber gloves and suitable shoes etc.

- xiv. The contractor shall be responsible for all the required activities for the successful running, committed energy generation & maintenance of the Solar Photovoltaic Power Plant covering:
- Deputation of qualified and experienced engineers and technicians at the facility.
  - Deputation of Security personnel for the complete security of plant.
  - Successful running of Solar Power Plant for committed energy generation.
  - Co-ordination with CTU/other statutory organizations as per the requirement on behalf of Employer for Joint Metering Report (JMR), furnishing generations schedules as per requirement, revising schedules as necessary and complying with grid requirements.
  - Monitoring, controlling, troubleshooting maintaining of logs & records, registers.
  - Furnishing generation data monthly to Employer/Owner by 1st week of every month for the previous month to enable Employer raise commercial bills on consumers.
  - Periodic cleaning of solar modules as approved by the Employer and water quality as per the recommendations of OEM.
  - Replacement of Modules, Invertors/PCU's and other equipment as and when required during the O&M period without additional cost to Employer.

### **1.8. Comprehensive Operation and Maintenance Contract**

- i. The Bidder shall separately quote in Annexure-4 for Operation and Maintenance of the power plant for Twenty-five (25) Years, wherein the plant should perform at a minimum annual NEEGG derated every year by not more than 1% referring to the installed DC capacity of the plant indicated by the Bidder. Any damage to CIVIL/ELECTRICAL/MECHANICAL components of the plant is to be reworked/replaced/supplied without any extra cost and time by the Contractor during maintenance period. This means after completion of O & M period every component of the plant should be in good and working condition.
- ii. Operation part consists of deputing necessary manpower necessary to operate the Solar Photovoltaic Power Plant at the full capacity. Operation procedures such as preparation to starting, running, routine operations with safety precautions, monitoring etc., shall be carried out as per the manufacturer's instructions to have trouble free operation of the complete system.
- iii. The Contractor shall ensure continuous, un-uninterrupted Plant Operation and Monitoring per NIB clause, for the period commencing from Plant Commissioning to the signing of the O&M Agreement.

- iv. The Employer shall enter into an O&M Agreement with the Contractor as per Annexure H: Operation & Maintenance Agreement subsequent to Plant Operational Acceptance. Daily work of the operation and maintenance in the Solar Photovoltaic Power Plant involves periodic cleaning of Modules including periodic tilt angle change as and when required, logging the voltage, current, power factor, power and energy output of the Plant at different levels. The operator shall also note down time/ failures, interruption in supply and tripping of different relays, reason for such tripping, duration of such interruption etc. The other task of the operators is to check battery voltage-specific gravity and temperature. The operator shall record monthly energy output, down time, etc.

## 1.9. Security Services

The contractor shall maintain vigilance for the security of the Solar Power Plant at his own cost, including deputation of security personnel. The security services shall be maintained during currency of the O&M Contract. The security staff may be organized to work on suitable shift system; proper checking & recording of all incoming & outgoing materials vehicles shall be maintained. Any occurrence of unlawful activities shall be informed to Employer immediately. A monthly report shall be sent to Employer on the security aspects. Any other activities required for completion of project, but not specified in the above shall be in the scope of contractor. The Contractor must provide the BOM of the plant as per the design during the time of submission of design basis report. The detailed technical specifications of major equipment to be followed strictly and are described in the technical specification section.

**Disclaimer:** Any civil / electrical / other work, which is not mentioned or included in this Tender document but necessary for the construction and O&M of 09 MW Ground mounted Solar PV Plant shall be borne by the Contractor. The Contractor shall, unless specifically excluded in the Contract, perform all such works and /or supply all such items and materials not specifically mentioned in the Contract/ Tender Document but can be reasonably inferred from the Contract as being required for attaining completion, commissioning and performance of the facilities, delivering NEEGG and maintaining the plant & achieving NEEGG during O&M period of 09 MW Ground mounted Solar PV Plant as if such work and / or items and materials were expressly mention in the Contract without any extra cost implication and liability to JREDA. All specifications mentioned in this Tender indicates minimum technical requirement. The Contractor may propose alternate specifications or design though the final acceptance of the same is subject to the Company's discretion.

## 2. Estimated Timeline of Project Completion

- 2.1. The contractor shall complete the entire project within 12 months from the date of WO/LOA. However, the contractor shall provide the O&M service till 25 years from date of COD of the plant. The Contractor shall provide full Programme of the supply in detail and delivery schedule along with work schedule thereto. Strict adherence and guaranteed delivery schedule mentioned in terms and conditions shall be the essence of the Contract and delivery schedule must be maintained. The work must be completed as per the Timeline mentioned below.

Sr.	Stage	Reference from Zero Date (“D”); Zero date shall be date of signing of contract
1.	Issue of Letter of Intent (LOA/Work Order) and signing of contract agreement	D
2.	Commencement of site development work	D+30
3.	Completion of fencing work of the project area.	D+45
4.	Completion of site developmental work	D+55
5.	Commencement of Civil Work	D+60
6.	Approval of major drawings	D+75
7.	Completion of supply of major balance of system (MMS, String Inverters, Inverter Duty/Power Transformers, cables etc.)	D+100
8.	Completion of supply of 100% Solar PV modules	D+120
9.	Completion of Erection and interconnection of 100% Solar PV Modules	D+150
10.	Completion of Civil Work & Erection of MMS	D+180
11.	Completion of Civil Work for Inverter Room, Control room, Switchyard & general civil work	D+180
12.	Installation and interconnection of all DC & AC circuit	D+210
13.	Interconnection of entire Plant & Testing	D+240
14.	Commissioning of Entire Plant in line with the procedure elaborated in the relevant regulations and Completion of all Facilities of the Plan as per Tender Specification	D+300
15.	Operational Acceptance Test	D+330
16.	Commercial Operation of the plant after completion OAT	D+365

**2.2.**The Contractor shall also provide a Bar/ PERT Chart indicating completion schedule for various items involved in the work within the stipulated completion period and the Contractor should strictly adhere to that schedule.

**2.3.**The issue of LoI shall be considered as the Zero Date

**2.4.**The Bar/ PERT Chart provided by the Contractor shall submitted to JREDA for approval prior to commencement of the execution of the Project. All comments and modifications provided by JREDA shall be incorporated and adhered to by the Contractor in the Timeline, Bar/ PERT Chart, detailed execution plan, etc. for execution of the Project.

**2.5.**This schedule shall be prepared so as to ensure the commissioning of complete plant within 180 days from issue of LoI.

**2.6. Partial commissioning of the solar PV plant shall not be considered.**

**3. Contract Price**

The bidder shall quote price as per schedule of items of work. The contract price shall be firm and binding and shall not be subject to any variation during the contractual completion period. The price shall be including GST and of all other taxes, duties and levies and 25 years CMC etc. as on the opening date of tender. However, bidder shall need to provide taxes and duties with the price bid. The price shall also include designing, manufacturing, inspection, supply, transport, insurance, handling etc. All applicable charges for taking necessary clearance such as commercial tax, road permit etc. wherever required are also deemed to be included in the contract price.

**4. Location of Site (s)**

The location of the project shall be as mentioned in the below table:

<b>Locations</b>	<b>Land area in (Acre)</b>	<b>Capacity of the power plant to be developed (MW)</b>	<b>Co-ordinates of Locations</b>	<b>Respective JBVNL / JUSNL S/s with approximate distance from location.</b>
Vill.: Parta, Block.: Haidarnagar, Dist.: Palamu	50	09 MW	Latitude: 24.5280661 Longitude: 83.9204249	JBVNL, 33/11 KV Deori S/s @ Approx. 05 – 07 KM

**5. Payment terms and conditions:**

The Total project cost is divided into two parts as mentioned below:

**Part-I: Payment on Design, Supply, Installation and Commissioning**

**Part-II: Comprehensive Maintenance Contract (CMC) service of 25 years**

**Bidders are required to quote their rate/price separately as format provided in the annexure-2 (Price bid format); further, the quoted cost for CMC service for 25 Years shall not be less than 35% ( annual O&M cost should not be less than 1.4% of the entire project cost) of the entire project cost (Design, Supply, Installation, Testing, commissioning, and CMC for 25 years).**

<b>Payment terms as per LOA/Work Order project value</b>	
<b>Part-I: Payment on Design, Supply, Testing, Installation and Commissioning</b>	
<b>70% (On Supply and Delivery of Goods)</b>	70 % of the 1 <sup>st</sup> part of the Project/Contract value excluding CMC cost shall be paid against supply and delivery of goods/equipment in full/complete and in good condition as certified by Consignee. Payment against the supply of items shall be as per follows: <ul style="list-style-type: none"> <li>• 40% of EPC cost (Part-1) against supply and delivery of SPV modules to work site.</li> <li>• 15% of EPC Cost (for Part-1) on supply and receipt of material following items:</li> </ul>

	<p>I. MMS Structure, Inverters, DC Cable, Junction boxes etc.) at site.</p> <p>II. Other Balance of System (BOS) such as Danger boards, Signages, Fire extinguishers, Drawings and manuals etc.</p> <p>III. All Required Civil Materials</p> <ul style="list-style-type: none"> <li>• 15% of EPC Cost (Part-1) on supply and receipt of material following items:             <ol style="list-style-type: none"> <li>I. Transformer and its components and other sub-station development related components.</li> <li>II. Supply of Balance of System includes all equipment, materials, spares, accessories, 33 kV Switchyard including 2 nos. of 33 kV Bays at plant level,) etc.</li> <li>III. Monitoring System, SCADA, CCTV and other safety &amp; security items.</li> <li>IV. Any Other items not listed above.</li> </ol> </li> </ul> <p>JREDA Officials subject to submission of following documents:</p> <ol style="list-style-type: none"> <li>a) Original Commercial invoice raised from the state of Jharkhand for the supply made in triplicate (1+2).</li> <li>b) Copy of duly raised delivery challan /E-way bill/ transportation challan /lorry receipt/dispatch clearance.</li> <li>c) Duly filled Annexure-14 should be submitted in three sets (one for Consignee record, one for JREDA Hq. and one for JREDA Executive Engineer).</li> <li>d) Photographs of all the equipment (materials) at destination with signature &amp; seal of Consignee/JREDA Officials. This record should be kept in the office of Consignee for verification.</li> <li>e) Submission of the Insurance Documents and Warranty and Guarantee Certificates of the Components.</li> </ol>
<p style="text-align: center;"><b>20%</b> <b>(On complete Installation/ Erection of the components including all civil works)</b></p>	<p>20% of the 1<sup>st</sup> part of the Project/contract value excluding CMC cost shall be paid against complete installation and erection of the followings:</p> <ul style="list-style-type: none"> <li>• Upon complete erection of Module Mounting Structure at site</li> <li>• Upon complete erection of String Inverters at site</li> <li>• Upon erection and acceptance of installation of all Solar PV modules on module mounting structures at site</li> <li>• Upon completion of all necessary civil works including fencing, boundary and sub-station construction, transformer bay etc.</li> <li>• Upon complete delivery of Balance of Systems including transformers, cables etc. at site.</li> <li>• Upon completion of any other necessary works required before OAT.</li> </ul>

	<p>Above works shall be inspect by the JREDA officials before release of payment and bidders required to submit following documents before processing payments:</p> <ol style="list-style-type: none"> <li>a) Original Commercial invoice raised from the state of Jharkhand for the service (I&amp;C) made in triplicate (1+2).</li> <li>b) Joint inspection report jointly signed by JREDA official and developer.</li> <li>c) Submission of the Insurance Documents and Warranty and Guarantee Certificates of the Components.</li> </ol>
<p style="text-align: center;"><b>10% On successful achieving Operational Acceptance Test (OAT) &amp; Commissioning</b></p>	<p>10% of the 1<sup>st</sup> part of the Project/contract value excluding CMC cost shall be paid against achieving of Operational Acceptance Test and Successful commissioning of plant or on COD.</p> <p>Above works shall be inspect by the JREDA officials before release of payment and bidders required to submit following documents before processing payments:</p> <ol style="list-style-type: none"> <li>a) Original Commercial invoice raised from the state of Jharkhand for the service (I&amp;C) made in triplicate (1+2).</li> <li>b) Joint inspection report for OAT and Commissioning of the plant jointly signed by JREDA official and developer.</li> <li>c) Submission of OAT certificate issued by JREDA upon report of developer.</li> <li>d) Commissioning certificate</li> </ol>
<p><b>Part-II: Comprehensive Maintenance Contract (CMC) service of 25 years</b></p>	
<p><b>Payment shall be released on annual basis on completion of successful CMC services.</b></p> <p><b>Developer/Contractor shall raise invoice to JREDA on annual basis to claim the CMC amount.</b></p>	<ul style="list-style-type: none"> <li>• Developer shall also require to submit CMC report on monthly basis to JREDA</li> <li>• The payment shall be released after submission of following documents in prescribed format.             <ol style="list-style-type: none"> <li>a) Copy of Original Commercial invoice raised at the time of supply in triplicate (1+2).</li> <li>b) Submission of annual report of CMC (combined for 12 months) as per Annexure-10.</li> </ol> </li> </ul> <p><b>Rights to award Transfer/Award CMC work:</b> In case agency fails to comply CMC report as per Work Order i.e.</p> <ol style="list-style-type: none"> <li>a) Fails to submit CMC report or fails to attend/resolve complain after two notices issued by JREDA or two months whichever is earlier, 2<sup>nd</sup> part of the work order will be transferred to any of the technically qualified agency under that same NIB on quotation basis. The submitted performance bank guarantee of the agency will be forfeited along with necessary action as per prevailing rules.</li> </ol>

**Note:**

- i. The Contractor shall submit all the invoices related Project and invoices of the O&M to The Director, JREDA, Ranchi. All material shall be consigned to Director, JREDA, Ranchi, Jharkhand.
- ii. The O&M payment for works shall be released on quarterly basis.
- iii. Contract Value/Work Order Value of Works means the Contract value of the Works (all Supply, erection/installation testing and commissioning, insurance, O&M works) part of the EPC Contract Price/Work Order Value.
- iv. Commercial Operation Date” (COD): with respect to the Project/Unit shall mean the date on which the project /unit is commissioned (certified by JREDA) and available for commercial operation and such date as specified in a written notice given at least 10 days in advance by the EPC Contractor to JREDA.
- v. The Contractor shall submit the bill / invoice for the work executed showing separately GST, and any other statutory levies in the bill / invoice.
- vi. All taxes and deductions shall be applicable as per prevailing income tax and other statutory rules and provisions in force.
- vii. While making payment for each invoice, amount of GST and applicable cess will be kept under retention till submission of documentary proof of payment of GST or till reflection of payment of GST pertains to respective bill amount in GST Return for concern Order after due verification. TDS will be applicable as per the Govt. Notification on the total order value of supply including Taxes & Duties, GST, etc.

## 6. Security Deposit for Contract Period

Successful bidder shall submit a security deposit @10% of the total contract order value of Supply, Erection, Installation, and commissioning including CMC value in the form of DD/BG/FDR (BG format in Annexure-8) within thirty (30) days from the date of issue of Letter of Intent (LoI)/LOA. Contract security cum Performance Guarantee shall be valid for a period of one year (12 months) from the date of issue of LoI or till the date of successful completion of Operational Acceptance Test (OAT) or COD whichever is earlier; if required, the PBG shall have to be extended for further 3 or more months beyond the due date of successful completion of OAT test. If Bank Guarantee not submitted within the stipulated period from the date of issuing the work order, then JREDA shall cancel the work order.

- 6.1.** The Security Deposit shall be refunded/released to the bidder after 60 days from successful achieving the OAT or COD of the plant as mentioned below:

Bidders	Deposit Validity	Refund Timeline
10 % of the Contract Value	Minimum 1 Year or till successful achieving of Operational Acceptance Test or COD	after 60 days from successful achieving

	(If contract period is extended due to delay in OAT/COD of the project, the bidder shall submit equal amount of PBG for the extended period)	the OAT or COD of the plant.
--	--	------------------------------

- 6.2.** The Security Deposit for Contract Period will have to be maintained by the bidder with JREDA till the completion of the execution period or till COD.
- 6.3.** In case the Contractor fails execute the project within due timeline i.e., 12 months shall attract delay charges @ 0.5% per week on the total Contract value maximum up to 10% of the work order value, calculated on pro-rata basis accordingly. However, total project completion period shall remain same. Further, JREDA has rights to extend the execution timeline in case of any unforeseen reason/circumstances/events.
- 6.4.** This Bank Guarantee must include and reflect in SFMS (Structural Financial Management System) facility, as per JREDA Bank Details Which is as:  
***Name of Bank: State Bank of India***  
***IFSC Code: SBIN0009010***  
***Branch Details: Ashok Nagar Branch, Ranchi***
- 6.5.** If Bidder fails to carry out the EPC work as per the provisions of the tender documents, then such Bidder's EMD amount shall be encashed/forfeited and may be blacklisted for future awards of work.
- 6.6.** Non submission of Contract Performance Guarantee within the time frame, shall lead to forfeited of EMD amount and cancellation of the work order.

## **7. Performance Security for CMC Period of 25 Years**

- 7.1.** The Contractor shall undertake comprehensive operation and maintenance (O&M) activities for a period of twenty-five (25) years from date of COD. The Contractor shall submit the O&M Bank Guarantee in form of DD/BG/FDR to JREDA within 30 days from the date of start of O&M period as specified in the NIB of this Tender in favour of the Director, Jharkhand Renewable Energy Development Agency, Ranchi, Jharkhand. The O&M Performance Security shall be 5% of the Contract Value valid up to an aggregate period of Twenty-Five (25) years from the initiation of O&M period. The minimum validity of the Bank guarantee shall be five (5) years and shall be renewed subsequently every five (5) years prior to Forty-Five (45) days of its expiry till 25 years. The format of the O&M Bank Guarantee is given in Annexure-8: Format of O&M Bank Guarantee.
- 7.2.** The successful bidders must submit the performance security in form of DD/BG/FDR for entire CMC period i.e., 25 Years as mentioned in the below table.

<b>Bidders</b>	<b>PBG Validity</b>	<b>Refund Timeline</b>
5 % of the Total Contract Value (INR)	Bidder shall submit Performance Security with minimum 5 years	<b>Every 5 Years</b> Performance Security shall be refunded within 30 days from

	<p>validity years) in each 5 years till completion of entire 25 years. The bidder needs to submit new Performance Security at least before 45 days from expiry of existing Performance Security in every five years till 25 years.</p>	<p>date of expiry of existing Performance Security in every 5 years. Performance Security shall be released in 5 years basis subject to successful completion of the CMC in each year.</p>
--	--	--

- 7.3. The Performance Security will have to be maintained by the bidder with JREDA till the completion of the CMC period.
- 7.4. This Bank Guarantee must include SFMS (Structural Financial Management System) as per JREDA Bank Details Which is as:  
*Name of Bank: State Bank of India*  
*IFSC Code: SBIN0009010*  
*Branch Details: Ashok Nagar Branch, Ranchi*
- 7.5. If Bidder fails to carry out CMC the work to him as per the provisions of the tender documents, then such Bidder's Performance Security amount shall be encashed and may be blacklisted for future awards of work.
- 7.6. Non submission of Performance Security within the time frame, shall lead to forfeited of contract security amount and cancellation of the CMC order.

**8. 25 Years Comprehensive Maintenance Contract (CMC)**

- 8.1. The Grid Connected SPV Power Plant capacity of 9 MW (AC) contract price includes the provision of 25 years mandatory Comprehensive Maintenance Contract (CMC). To ensure long term sustainability of the system, the bidder must provide his representatives name, full address, mobile number and photographs to JREDA with one hard copy as well as the names and contact details of all technicians must also be provided within 15 days of issuance of the LOA/Work Order. Failure to do shall invite penalty and action. Refer to Scope of Works clause for detailed O& M works to accomplished by contractor.
- 8.2. The Comprehensive Maintenance Contract shall include servicing & replacement guarantee for parts and components (such as Electrical items, electronics items, Inverter, PV modules, Substation's components, AC system, DC system, Transformers, Monitoring system, SCADA system, Safety system, security system components and other hardware) for twenty-five years from the date of COD . PV modules shall be warranted for 25 years. The date of CMC maintenance period shall begin on the date of actual commissioning (COD) of SPV Power Plant. It is mandatory for the contractor to carry out CMC regularly and submit report to JREDA monthly as per the format for CMC and schedules mentioned in this tender. Failure to submit monthly CMC reports timely shall invite penalty and action.
- 8.3. Penalty during O&M period against breakdown of other Infrastructure of Plant facilities that

don't affect the generation of power directly, such as but not limited to, civil infrastructure, water supply system/network, other Infrastructure developed by the Contractor as a Scope of Work for the Project (Section-V: Scope of Works & Technical Specifications) shall be penalised @ Rs.1000/day, for non-compliance with PM Schedule (Initiation/Completion of Scheduled maintenance Activity as agreed under this Contract) beyond 48 hours. Cumulative value of such penalty shall be limited to 5% of yearly O&M cost.

## **9. Net Electrical Energy Generation Guarantee (NEEGG)**

- 9.1.** The Bidder shall be required to quote the Net Electrical Energy Generation Guarantee (NEEGG) for Twenty-five (25) year's period. The Bidder shall give NEEGG per annum after considering proposed configuration and all local conditions, solar insolation, wind speed and direction, air temperature & relative humidity, barometric pressure, rainfall, sunshine duration, grid availability and grid related all other factors and losses due to near shading, incidence angle modifier, irradiance level, temperature loss, array loss, module quality loss, module array mismatch loss, soiling loss and various inverter losses etc. To assess/ verify feasibility of quoted NEEGG, Bidders are required to provide computation documents along with considered factors based on which NEEGG has been computed.
- 9.2.** Bidders are expected to undertake their own study of solar profile and other related parameters of the area and make sound commercial judgment about power output i.e. Net Electrical Energy Guaranteed Generation. The Site information and solar data provided in this Tender except the reference radiation for the twelve (12) months is only for preliminary information purpose. No claim or compensation shall be entertained on account of this information. It shall be the responsibility of the Bidder to access the corresponding solar insolation values and related factors of solar plant along with expected grid availability. The Bidder should access all related factors about the selected Site for the Project and then quote the NEEGG for the proposed Project.
- 9.3.** The Contractor shall be responsible for achieving NEEGG. For any shortfall in NEEGG corresponding to the offer, the compensation shall be recovered from the Contractor as per SCC, Clause No.10. The Contractor shall maintain the Plant equipment including its repair, replacement, overhauling, etc., so as to give the agreed NEEGG per year, for which JREDA shall pay the agreed O&M Contract Price and the applicable taxes.
- 9.4.** The Bids with NEEGG of less than **16,514,495 kWh** for the First Year for 9 MW(AC) Ground Mounted Solar Project shall be summarily rejected.
- 9.5.** The NEEGG quoted for each consecutive year should have maximum 1% annual degradation factor in NEEGG. If the bidder anticipates any degradation of the modules during the first year, it shall be taken care of to provide additional capacity of solar PV modules to meet guaranteed generation at the end of first year to avoid liquidated damages/compensation on account of Performance Guaranteed Generation.
- 9.6.** This NEEGG shall be used for the evaluation of the Bids as specified in above clauses.

#### **10. Penalty for Loss of Generation during O&M**

For each Contract Year, the Contractor shall demonstrate “Actual Delivered Energy” at the Metering Point as compared to the ‘Base NEEGG’ for the particular year as mentioned in this RfP. If for any Contract Year, it is found that the “Actual Delivered Energy” is less than ‘Base NEEGG’ for the particular year, the Contractor shall pay the compensation to JREDA equivalent to Rs. **[JREDA’s PPA\*1.50] per kWh** of under generation. In addition, JREDA will also recover from the Contractor, the full penalty (including the charges of Renewable Energy Certificate) imposed by the Company’s Power Purchaser on the Company due to less generation, as per agreement between JREDA and Power Purchaser. All penalties shall be recovered from payments yet to be made by JREDA to the Contractor and/ or from the Bank Guarantees available with JREDA. Liquidated damage on underperformance shall be charged on the NEEGG considering the actual weather data received at the plant size.

#### **11. Preventive/Routine Maintenance**

This shall be done by the supplier/contractor at least twice in every month and shall include activities such as, cleaning and checking the health of the SPV system, cleaning of module surface, tightening of all electrical connections, regular checks to identify any leakage of electricity, cleaning & AC and DC system and any other activity that may be required for proper functioning of the Solar Photovoltaic Power Plant. Necessary maintenance activities, preventive and routine for Transformers and associated switchgears also shall be included. The maintenance record should be kept properly and to be submitted at JREDA office time to time. CMC documents should be certified by Beneficiary.

#### **12. Breakdown / corrective Maintenance**

Whenever a fault has occurred, the Contractor has to attend to rectify the fault, the fault must be rectified within 24 hrs time from the time of occurrence of fault failing which the Contractor will be penalized as per terms and conditions of this Tender.

#### **13. Liquidated Damages for Delay in Completion & CMC**

If the contractor fails to deliver any material as project site or any part of the equipment or complete the work within the time fixed under the contract or any extension thereof granted to him by JREDA and/or to fulfill his obligations in time under the contract, he shall be liable to pay to JREDA @0.5% per week maximum up to 10% of work value delayed beyond contract period. The same will be applicable if monthly CMC report will not be submitted within a week of due date.

## **SECTION-6: TECHNICAL SPECIFICATIONS**

**NIB No. 12/JREDA/SSP/PAL/2024-25**

## 1. Technical Specification

All components of the Solar PV plant shall be in accordance with technical specifications given in relevant IS/ IEC/BIS Standards. The design and commissioning also shall be as per latest IS/ IEC/ BIS standards. The following are some of the technical measures required to ensure quality of the major components used in grid connected solar power Projects.

## 2. Minimum assured items/Components services and technical specifications

### 2.1.Solar Photovoltaic (SPV) modules

- i. In line with MNRE ALMM list (10th May 2023 and its updated list via its OM No. 283/41/2024- GRID SOLAR. dated 24th May 2024) the contractor shall ensure to meet the minimum efficiency requirement i.e., more than 20 % for crystalline-silicon technology based Solar PV modules and it also mandatory to procure PV modules as listed in ALMM Annexure -1 of above OM and amended from time to time.
- ii. The Contractor shall employ solar PV module of Crystalline-Si (Poly / Multi or Mono / Single) solar technology only. The Contractor shall provide detail Technical Data Sheets, Certifications of Standard Testing Conditions (STC: defined as Standard Testing Condition with air mass AM1.5, irradiance 1000W/m<sup>2</sup>, and cell temperature 25°C) as per the latest edition of IEC 61215 and as tested by IEC / MNRE recognized test laboratory. The Bidder shall also specify the minimum guaranteed energy output of solar PV module as per the Site Condition in the Bid. PV module must be registered with BIS.
- iii. The PV modules to be employed shall be of minimum 72 cell configuration with rated power of module  $\geq 540$  Wp as certified for solar PV module power performance test as prescribed by latest edition of IEC 61215 and as tested by IEC / MNRE recognized test laboratory. The maximum tolerance in the rated power of solar PV module shall have maximum tolerance of +3%. No negative tolerance in the rated capacity of solar PV module is allowed.
- iv. All modules shall be certified IEC 61215 2nd Ed. (Design qualification and type approval for Crystalline Si modules), IEC 61730 (PV module safety qualification testing @ 1000 V DC or higher). IEC 62804 Certified PV modules should be PID free, documents for the same should be submitted with conditions of the PID test should be for a humidity of 85 % and a cell temperature of 85<sup>0</sup> C at 1000Volts , IEC 62716 , IEC 61701.
- v. The certified Bill of Material (BOM) to be used in the PV Modules should be the same as used during the IEC certification of reference PV Module certified by renowned agency like TUV, UL, etc.
- vi. All photovoltaic modules should carry a performance warranty of >90% during the first 10 years, and >80% during the next 15 years. Further, module shall have performance warranty of > 97% during the first year of installation and degradation of PV module shall not be more than 1% in any particular year.

- vii. SPV module shall have module safety class-II and should be highly reliable, light weight and must have a service life of more than 25 years.
- viii. The PV modules shall be equipped with IP67 or higher protection level junction box with min. 3 by pass diodes of appropriate rating and appropriately sized output power cable of symmetric length with twist locking connectors.
- ix. The SPV module shall be made up of high transitivity glass & front surface shall give high encapsulation gain and the module shall consists of impact resistance, low iron and high transmission toughened glass. The module frame shall be made of corrosion resistant material, which shall be electrically compatible with the structural material used for mounting the modules.
- x. The SPV modules shall have suitable encapsulation and sealing arrangements to protect the silicon cells from environment. The encapsulation arrangement shall ensure complete moisture proofing for the entire life of solar modules.
- xi. The module frame should have been made of Aluminum or corrosion resistant material, which shall be electrolytically compatible with the structural material used for mounting the modules with sufficient no. of grounding/installation.
- xii. All materials used for manufacturing solar PV module shall have a proven history of reliability and stable operation in external applications. It shall perform satisfactorily in relative humidity up to 95% with temperature between -40°C to +85°C and shall withstand adverse climatic conditions, such as high speed wind, blow with dust, sand particles, saline climatic / soil conditions and for wind 170 km/hr on the surface of the panel.
- xiii. The Bidder shall provide to the Company in the Bid, power performance test data sheets of all modules. The exact power of the module shall be indicated if the data sheet consists of a range of modules with varying output power.
- xiv. JREDA or its authorized representative reserves the right to inspect the modules at the manufacturer’s site prior to dispatch. JREDA shall only bear the cost of travel for their own employee/authorized representative/consultants. Contractor has to bear travelling cost for their personnel. However, all the cost related to testing facilities shall be borne by the Contractor.
- xv. The Bidder is advised to check and ensure the availability of modules prior to submitting the Tender Document.

<b>Solar PV Module / Panel Technical Standards to be followed</b>	
IEC 61215 and IS 14286	Design Qualification and Type Approval for Crystalline Silicon Terrestrial Photovoltaic (PV) Modules
IEC 61701:2011	Salt Mist Corrosion Testing of Photovoltaic (PV) Modules

IEC 61853- 1:2011 / IS 16170-1:2014	Photovoltaic (PV) module performance testing and energy rating –: Irradiance and temperature performance measurements, and power Rating.
IEC 62716	Photovoltaic (PV) Modules – Ammonia (NH <sub>3</sub> ) Corrosion Testing (as per the site condition like dairies, toilets etc.)
IEC 61730-1,2	Photovoltaic (PV) Module Safety Qualification – Part 1: Requirements for Construction, Part 2: Requirements for Testing
IEC 62804	Photovoltaic (PV) modules – Test method for detection of potential induced degradation. IEC 62804-1: Part 1: Crystalline Silicon

## 2.2.Power Conditioning Unit (PCU)/ Inverter

### i Codes and Standards:

The PCU shall conform to all applicable IEC standards. Where an applicable IEC standard is not available, IS/ any applicable international standard shall be referred to as best practice.

IEC-61683	Energy efficiency requirements
IEC 61000	Emission/ Immunity requirement
IEEE 519	Recommended Practices and Requirements for Harmonic Control in Electrical Power Systems.
IEC 60068-2-1, 2, 6, 14, 27 & 30	Environmental Testing
IEC 62116	Testing procedure—Islanding prevention measures for power conditioners used in grid-connected photovoltaic (PV) power generation systems
IEC 62109-1 & 2	Safety of power converters for use in photovoltaic power systems
EN 50530	Overall efficiency of grid connected photovoltaic inverters
BDEW 2008	Technical Guidelines for Generating plant connected to Medium voltage network
IEEE 1547	Standard for interconnecting distributed resources with electrical power systems.
IEC 60529	Ingress protection test
Grid Connectivity	CEA Technical Standards for Connectivity to the Grid Regulations 2007 with 2013 and 2019 as amended and revised from time to time.
Any Other	As per the Solar Photovoltaics, Systems, Devices and Components Goods (Requirements for Compulsory Registration) Order, 2017, Inverters used in the grid connected solar power projects shall be registered with BIS and bear the Standard Mark as notified by the Bureau of Indian Standards

## ii **General Requirements of String Inverter:**

- The minimum euro efficiency of the String Inverter as per IEC 61683 shall be 98%. The bidder shall specify the conversion efficiency at following load conditions i.e. 25%, 50%, 75% and 100% during detail engineering, which shall be confirmed by type test reports.
- The String Inverter shall remain connected to the grid as per Central Electricity Authority Technical (standards for connectivity to the grid) regulation 2007 with all latest amendments and its components shall be designed accordingly.
- In case auxiliary supply of String Inverter is met internally, then it should have sufficient power backup to meet the LVRT requirement. Bidder needs to submit the detail auxiliary supply arrangement for String Inverter during detail engineering stage.
- The String Inverter shall be capable of operating in the frequency range of 47.5 Hz to 52 Hz and shall be able to deliver rated output in the frequency range of 49.5 Hz to 50.5 Hz.
- The monitoring/measurement of DC inputs and AC output shall be done using transducers/instruments having sensor accuracy of 0.5 class or better.
- Internal Surge Protection Device (SPD) shall be provided in the String Inverter on DC and AC side. It shall consist of Metal Oxide Variaster (MOV) type arrestors. The discharge capability of the SPD shall be at least 12.5kA at 8/20 micro second wave as per IEC 61643-12.
- The String Inverter shall be capable of supplying reactive power as per grid requirement (manual intervention through SCADA) during solar generation hours. However, reactive power support, below 0.95 power factor, might be as the behest of active power.
- The String Inverter shall have protection against any sustained fault in the feeder line and against lightning discharge in the feeder line.
- The Contractor shall ensure by carrying out all necessary studies that the String Inverter will not excite any resonant conditions in the system that may result in the islanded operation of PV plant and loss of generation. In case there is excitation of any resonant condition in the system during PV plant operation that may result in the islanding/tripping of the PV plant and affect the power transfer, it shall be the responsibility of contractor to rectify the design and carryout required modification in the equipment of his supply.
- The String Inverter must be self-managing and stable in operation.
- In case of grid failure, the String Inverter shall be re-synchronized with grid after revival of power supply. Bidder to furnish the time taken by String Inverter to be re-synchronized after restoration of grid supply during detailed engineering.
- The String Inverter shall include appropriate self-protective and self-diagnostic feature to protect itself and the PV array from damage in the event of String Inverter component failure or from parameters beyond the String Inverter's safe operating range due to internal or external causes. The self-protective features shall not allow signals from the String Inverter front panel to cause the String Inverter to be operated in a manner which may be unsafe or damaging. Faults due to malfunctioning within the String Inverter, including commutation failure, shall be cleared by the String Inverter protective devices.
- String Inverter shall have active power limit control, reactive power and power factor control feature. Plant operator shall be able to provide (manual intervention) Active power,

reactive power and power factor control/limit set point through SCADA HMI and local control display unit (or Laptop computer). String Inverter shall be provided with remote start and stop facility from SCADA HMI. All required hardware and software required for this purpose shall be provided by Bidder.

- String Inverter shall have necessary limiters in build in the controller so as to ensure safe operation of the String Inverter within the designed operational parameters.
- String Inverter shall have thermal overloading protection to prevent failure of switching devices (i.e. IGBT) and other components of Inverter. String Inverter controller shall automatically regulate/limit the power output in order to reduce the String Inverter cabinet and switching devices temperature. Bidder to submit the String Inverter power vs ambient temperature curve during details engineering stage. String Inverter shall be able to provide inverter inside cabinet and IGBT's (switching device) temperature (in soft analog value) to SCADA system for remote monitoring, storing and report generation purpose.
- String Inverter shall have the following feature,
  - a) AC & DC overcurrent protection.
  - b) Synchronization loss protection.
  - c) Over temperature protection.
  - d) DC & AC under and over voltage protection.
  - e) Under & over frequency protection.
  - f) Cooling system failure protection
  - g) PV array ground fault monitoring & detection
  - h) PV array insulation monitoring
  - i) LVRT
  - j) Anti-islanding protection
  - k) Grid monitoring
- One number of laptop having latest configuration with fully loaded/programmed with required licensed software shall be supplied for String Inverter configuration and troubleshooting purpose. Laptop shall be supplied with complete set of hardware & software accessories. Laptop detailed configuration must ensure suitability for the required applications. Supplied Laptop shall be protected with the latest anti-virus software and shall be provided 3 Years onsite warranty including its battery. At least two sets of communication cable for Laptop to String Inverter communication shall be provided.
- String Inverter shall be provided with Mobile user interface facility for monitoring of inverter by plant O&M personal for better O&M and highest yield from PV plant. Also, bidder can provide the same facility through plant SCADA system.
- String Inverter shall have AC and DC side monitoring capability and reporting to SCADA system (measured analog and digital value measured within String Inverter). Any special software if required for these purposes shall be provided for local and remote monitoring and report generation.
- DC Overloading: Maximum PCU DC overloading shall be limited to its design PV Array power to String Inverter nominal AC power ratio. Bidder needs to submit all the relevant technical documents/test report from String Inverter manufacturer (OEM) during detailed engineering stage in support of declared String Inverter design DC overloading capacity.

### iii Earthing of String Inverters:

The String Inverter shall be earthed as per manufacturer recommendation. During detail engineering the Bidder needs to submit the details earthing arrangement of String Inverter and system earth pit requirement during detail engineering stage. The detail specification for panel earthing for safety has been mentioned elsewhere in this specification.

### iv Operating Modes of String Inverters:

- a) **Low Power Mode:** - The String Inverter shall be able to wake-up automatically when PV array open circuit voltage value is equal/more than preset value in the String Inverter program. Once it starts generation the String Inverter shall automatically enter maximum power mode.
- b) **Maximum Power Point Tracking (MPPT):** In order to maximize the energy collection from solar PV array, the String Inverter shall have inbuilt maximum power point tracker (MPPT) controller and MPPT shall be able to operate the PV array at its maximum power point by adjusting output voltage of PV array system according to atmospheric condition. String Inverter MPPT controller shall ensure that it operates the PV array system at its global maximum power point and it shall not trap into PV array local maximum power point during cloudy atmospheric condition. The String Inverter shall operate within its MPPT operating input DC voltage range (window). The String Inverter MPPT operating DC voltage range shall be large enough so that it shall be able to satisfactorily operate the PV modules exposed to the maximum ambient temperature of 50°C or any other condition. In case the solar PV array operating maximum power point voltage falls below (or above) the String Inverter MPPT operating voltage range, then the String Inverter controller shall automatically adjust the String Inverter input voltage so that String Inverter shall not enter into sleep mode. If the PV array output power falls below the String Inverter minimum preset power value then String Inverter shall automatically switch to sleep mode. In case, PV modules connected to Inverter are in Flickering shading zone of Wind turbines, Suitable MPPT algorithm shall be adopted for those Inverters to optimize Energy Yield.
- c) **Sleep Mode:** String Inverter shall automatically go into sleep mode when the output voltage of PV array and/or output power of the String Inverter falls below a specified limit. During sleep mode the inverter shall disconnect from grid. Inverter shall continuously monitor the output of the PV array and automatically start when the DC voltage rises above a pre-defined level. During evening and night (non solar generation hours) the String Inverter shall be in sleep mode in order to minimize the internal power loss. Maximum loss in sleep mode shall be less than 0.05% of String Inverter rated power.
- d) **Standby Mode:** In standby mode the String Inverter DC & AC contactor are open, inverter is powered on condition and waiting for start command.

**String Inverter shall meet the following technical parameter:**

Parameter	Specification
Rated Input power DC	As per design
Max Input Voltage	1000V or 1500V as per application
Rated Power AC output Voltage	As per design
Nominal output voltage frequency	50Hz
Continuous operating frequency range	47.5 Hz to 52 Hz
Continuous operating AC voltage range	± 10% rated AC voltage
European efficiency Minimum 98%	European efficiency Minimum 98%
Operating power factor range	Operating power factor (adjustable) shall be 0.9 Lead to 0.9 Lag.
Current THD value	< 4% at nominal load
Operating ambient temperature	0 to 50 ° C
Humidity	95 % non-condensing
Maximum Noise level (at 1 meter distance)	75 dBA for outdoor type String Inverter
DC Injection	<0.5 % at rated current
Degree of Protection	String Inverter – IP 65

**v String Inverter Details:**

- The string inverter enclosure protection class shall be IP 65 or better protection.
- The string inverter should be placed inside a canopy shed with at least 25 cm in all direction, if installed in open. Alternatively, the Bidder can also install the inverter on the column post of the module mounting structure, below the modules. In such case, the canopy is not required and the column and foundation shall be designed accordingly.
- String inverter shall have suitable communication port (RS485/TCP-IP/PLC) for SCADA integration. All necessary hardware, software and accessories used for communication with SCADA (including Data logger if supplied) at both the ends shall be provided by the bidder.
- String inverter shall have string monitoring capability and reporting to SCADA system. Any special software if required for this purposes shall be provided for remote monitoring and report generation.
- Anti-PID device along with all hardware and communication cable/device shall be provided in case negative grounding of PV string provision is not available in string inverter. Data logger used in Anti-PID device shall be integrated with SCADA system.
- DC fuse requirement for PV string at string inverter end shall be as per string manufacturer/system requirement and same shall be finalized during detail engineering stage.
- Provision for AC electrical isolation device (such as MCB/MCCB/Isolator) inside string shall be as per string inverter manufacturer practice.
- Local Display unit for viewing important parameters, configuration and troubleshooting purpose shall be provided as per string inverter manufacture practice.

**vi Type Testing:**

During detailed engineering, the contractor shall submit all the type test reports including temperature rise test and surge withstand test carried out within last ten years from the date of techno-commercial bid opening for Owner's approval. These reports should be for the test conducted on the equipment similar to those proposed to be supplied under this contract and the test(s) should have been either conducted at an independent laboratory or should have been witnessed by a client. However if the contractor is not able to submit report of the type test(s) conducted within last ten years from the date of techno-commercial bid opening, or in the case of type test report(s) are not found to be meeting the specification requirements, the contractor shall conduct all such tests under this contract at no additional cost to the owner either at third party lab or in presence of client/owners representative and submit the reports for approval.

**2.3.Cables and Wires**

- i. All cables and connectors for use for installation of solar field must be of solar grade which can withstand harsh environment conditions for 25 years and voltages as per latest IEC standards. (Note: IEC standards for DC cables for PV systems is under development, the cables of 1000-1800 volts DC. DC cables for outdoor installations should comply with the EN50618 / TUV 2PFG 1169/09.07 or equivalent IS for service life expectancy of 25 years.
- ii. Wires with sufficient ampacity and parameters shall be designed and used so that maximum voltage-drop at full power from the PV modules to inverter should be less than 1.5% (including diode voltage drop). PV Modules should be connected with USE-2/RHW-2 cables array to junction box conductors and junction box to photovoltaic disconnecter with the THHN/THWN-2 sunlight resistant with 90°C wet rated insulation cable. Due consideration shall be made for the de-rating of the cables with respect to the laying pattern in buried trenches / on cable trays, while sizing the cables. The Contractor shall provide voltage drop calculations in excel sheet.
- iii. All cables shall be supplied in the single largest length to restrict the straight-through joints to the minimum number. Only terminal cable joints shall be accepted. No cable joint to join two cable ends shall be accepted. All wires used on the LT side shall conform to IS and should be of appropriate voltage grade. Copper conductor wires of reputed make shall be used. Armoured Aluminium cable connecting SMB and Inverter and also for IT applications are allowed.
- iv. All cables shall be armoured except Solar Cables. Solar cable shall be laid through MMS / DWC Conduits.
  - v. OFC cable shall be laid in DWC conduits.
  - vi. Ethernet cables shall be CAT-6.
- vii. All wires used for connecting the modules and array should conform to the NEC standards. Modules should be connected with USE-2/RHW-2 cables array to junction box conductors and junction box to photovoltaic disconnecter with the THHN/THWN-2 sunlight resistant with 90°C wet rated insulation cable.
- viii. All high voltage cables connecting the main junction box/string inverters to the transformers should be PVC insulated grade conforming to IS 1554 and cables shall also conform to IEC 60189 for test and measuring the methods.
- ix. Irrespective of utilization voltage and current rating all type of power cables shall be minimum of 1100 V grade PVC insulated conforming to IS 1554 / IS 694 for working voltage less than

150 V control cable shall be of minimum 500 V grade, the control and power cable has to be laid separately. All LT XLPE cables shall confirm to IS: 7098 Part I. All HT XLPE Cables (33kV) Shall confirm IS: 7098 PART-2 & IEC -60287, IEC-60332 and the Contractor to submit technical data sheet, Voltage drop calculation, Power Loss Calculation and type test report for the approval of client / consultants.

- x. The cables shall be adequately insulated for the voltage required and shall be suitably color coded for the required service. Bending radius for cables shall be as per manufacturer's recommendations and IS: 1255.
- xi. All indoor (Installation Type) cables shall be FRLSH type.

**Table 0-1 Relevant Codes & Standards for Cable**

Sr.	Item	Relevant IS	Relevant IEC
1	Conductors of Insulated Cables	IS: 8130 - 1984	IEC: 228
2	Impulse tests on cables and their accessories		IEC: 230
3	Extruded solid dielectric-insulated power cables for rated voltage from 1 KV upto 30 KV.		IEC: 502
4	Test methods for insulations and sheaths of electric cables and chords.		IEC: 540
5	Test on cable over a sheath which has special protective functions and are applied by extrusion.		IEC: 229
6	Calculations of continuous current rating of cables (100% load factor).		IEC: 287
7	Cross-linked polyethylene insulated PVC sheathed cable for voltage from 3.3 KV upto 33 KV.	IS: 7098 (Part II)	
8	PVC insulation & sheath of electrical cables.	IS: 5831 - 1984	
9	Mild steel wires, formed wires and tapes for armouring of cables.	IS: 3975	
10	Electrical test methods for electric cables partial discharge test.		IEC: 885(2) - 1987 (Part II)
11	Methods of test for cables.	IS: 10810	
12	Common test methods for insulating and sheathing materials of electric cables.		IEC: 811
13	Impulse test on cables & other accessories		IEC: 230
14	Cable termination for gas insulated switchgear.		IEC: 859

**xii. Technical specification of LT XLPE cables**

- **General Constructional Features**

The medium voltage cables shall be supplied, laid, connected, tested and commissioned in

accordance with the drawings, specifications, relevant Indian Standards specifications, manufacturer's instructions. The cables shall be delivered at site in original drums with manufacturer's name, size, and type, clearly written on the drums.

- A. Material:** Medium voltage cable shall be XLPE insulated. PVC sheathed, aluminum or copper conductor, armored conforming to IS: 7098 Part I.
- B. Type:** The cables shall be circular, multi core, annealed copper or aluminum conductor, XLPE insulated and PVC sheathed, armored.
- C. Conductor:** Uncoated, annealed copper, of high conductivity upto 4 mm<sup>2</sup> size, the conductor shall be solid and above 4 mm<sup>2</sup>, conductors shall be concentrically stranded as per IEC: 228.
- D. Insulation:** XLPE rated 90° C. extruded insulation.

**E. Core Identification:**

Two core	:	Red and Black
Three core	:	Red, Yellow and Blue
Four core	:	Red, Yellow, Blue and Black
Single core	:	Green cable with Yellow strips for earthing

Black shall always be used for neutral.

**F. Assembly:** Two, three or four insulated conductors shall be laid up, filled with non-hygroscopic material and covered with an additional layer of thermoplastic material.

**G. Armour:** Galvanised steel flat strip / round wires applied helically in single layers complete with covering the assembly of cores.

- For cable size upto 25 Sq. mm. : Armour of 1.4 mm dia G.I. round wire
- For cable size above 25 Sq. mm. Armour of 4 mm wide 0.8 mm thick G.I strip

**H. Sheath:** The cable shall be rated extruded for XLPE 90 deg.c. Inner sheath shall be extruded type and shall be compatible with the insulation provided for the cables.

Outer sheath shall be of an extruded type layer of suitable PVC material compatible with the specified ambient temp 50 deg. C and operating temperature of cables. The sheath shall be resistant to water, ultraviolet radiation, fungus, termite and rodent attacks. The colour of outer sheath shall be black. Sequential length marking required at every 1.0 meter interval on outer sheath shall be available. The contractor has to furnish resistance / reactance / capacitances of the cable in the technical datasheet.

**I. Rating:** 1100 Volts or higher.

**xiii. Technical Specification Of HT XLPE Cables**

- **General Constructional Features**

**A. Conductors:**

The conductor shall be of circular stranded Aluminum confirming to IS: 8130 & IEC: 228. It shall be clean, reasonably uniform in size & shape smooth & free from harmful defects. Any other form of conductor may also be accepted if in line with modern trends.

**B. Semi-Conductor Barrier Tape/Tapes:**

The semi-conducting barrier tape/tapes shall be provided over the conductors.

**C. Conductor Screen:**

The conductor screen shall consist of an extruded layer of thermosetting semi-conducting compound which shall be extruded simultaneously with the core insulation.

**D. Insulation:**

The insulation shall be super clean XLPE compound applied by extrusion and vulcanized to form a compact homogenous body.

**E. Insulation Screen:**

- a. Each insulation have an insulation screen in two parts consisting of:
- b. A water barrier tape/Non-metallic semi-conducting swellable tape part and a metallic screen part.
- c. The non-metallic part shall be directly applied upon the insulation of each core and may consist of an impregnated but nylon/PVC tape or a similar approved material or, an extruded semi-conducting material extruded simultaneously with the conductor screen and insulation (triple extrusion).
- d. The semi-conductor shall be readily strippable and must not be bonded in such a manner that it has to be shaved or scraped to remove.
- e. The metallic part shall consist of a copper tape helical applied with a 30% overlap over the water barrier tape/blocking tape. A binder tape of copper shall be applied over the copper wire metallic screen.

**F. Laying Up:**

- a. The cores shall be identified on the non-metallic part of the insulation screen by legible printing on the length of each conductor or, by the inclusion of a marker tape.
- b. The cores shall be laid up with a right hand direction of lay.
- c. Binder tape/Moisture barrier:  
During layup, a suitable open spiral binder may be applied, at the manufacturer's discretion, before the application of an extruded inner covering.

**G. Fillers:**

Fillers shall be polypropylene.

**H. Inner Covering/Sheath:**

The inner covering shall be extruded over the laid up cores to form compact and circular bedding for the metallic layer.

**I. Metallic Layer:**

The metallic layer shall be galvanised steel wire.

**J. Outer Sheath:**

The tough outer sheath, black colored best resisting PVC polyethylene compound type ST-2 as per IS: 5831 for the operating temperature of the cable shall be provided over the armour as specified in relevant standards by extrusion process.

**K. Cable Marking:**

a. Embossing on outer sheath:

The following particulars shall be properly legible embossed on the cable sheath at the intervals of not exceeding one meter throughout the length of the cable. The cables with poor and illegible embossing shall be liable for rejection.

- JREDA Solar
- Voltage grade
- Year of manufacture
- Manufactures name
- Successive Length
- Size of cable
- ISI mark

b. Packing and marking shall be as per IS 7098 (part I)/1988 amended up to date.

c. Cables inside the control room and in the switchyard shall be laid in Galvanized Cable Trays mounted on mild steel supports duly painted, in constructed trenches with RCC raft and brick sidewalls and provided with removable RCC covers.

d. Cable terminations shall be made with suitable cable lugs & sockets etc, crimped properly and passed through brass compression type cable glands at the entry & exit point of the cubicles.

e. All cable/wires shall be provided with Punched Aluminium tags only. The marking on tags shall be done with good quality letter and number ferrules of proper sizes so that the cables can be identified easily.

f. The wiring for modules interconnection shall be in the GI pipe /HD Pipe of approved make.

g. Data sheets of individual cable sizes (HT & LT) shall be submitted for approval by the Company. Drum numbers and drum length details shall be submitted with each consignment.

h. Cable end terminations and joint kits shall comply with the latest version of the relevant IS standard.

i. The cable ends shall be terminated with adequate size copper lugs and sockets etc, single/double compression cable glands. Cable glands shall be of robust construction capable of clamping cable and cable amour (for armoured cables) firmly without injury to insulation. The metallic glands shall be earthed at two locations. Suitable lock type crimping lugs shall be used for cable end terminations. Where cables are raising from ground, suitable PVC pipe guarding shall be provided for cable raising with sealing of the guarding PVC pipe including a suitable clamp.

j. HT cable termination kits and straight through joints shall be selected as per the cable specifications. Installation shall be as per the instructions given in the manufacturer's manual. Heat shrinkable type kits only shall be used for HT and LT cables.

k. Data sheets of the joints and kits shall be submitted for approval by JREDA.

1. Short Circuit rating of HT cables shall be 25 kA for 3 sec or suitable to fault calculation, whichever is higher.

#### 2.4.Clamps and Connectors

- i. The bus-support clamps, spacers, T-connectors and various equipment connectors shall be supplied as per the enclosed drawings. The material to be used for these items shall be generally as per the technical specification of mentioned in NIB.
- ii. The materials shall be of the best workmanship, and all the sharp edges and corners shall be rounded off. The thickness of tinning, wherever applicable, shall be not less than 10 microns. The minimum thickness of pads made of copper shall be 10 mm and those made out of Aluminum/Aluminum Alloy, shall be 12 mm, unless otherwise indicated in the specifications.
- iii. All the clamps and connectors shall be designed to carry a continuous current not less than 125% of the rated current of the conductor (twin/single as the case may be)/equipment terminal to which these are to be connected. Temperature rise of the connector under the above condition shall not be more than 50% of the temperature of the main conductor/equipment terminal.

**Table 0-2 Clamps & Connectors**

Sr.	Application	Material
1.	Bolted type connection	
2.	For connection to ACSR/AAAC/ Aluminium terminal	Aluminium Alloy conforming to designate A6 as per IS 617
3.	For connection to copper terminals, with crimping facility to connect ACSR/AAAC jumper	Electrolytic grade copper, forged and tinned
4.	Crimping type connection	
5.	For connection to ACSR/AAAC jumper	Electrolytic grade aluminium

- iv. All the fasteners (i.e., nut-bolts, washers, check-nuts, etc.) used in the clamps and connectors shall be of non-magnetic stainless steel. The straight bolts shall be fully threaded, and the U-bolts shall be threaded up to 30 mm from the ends. For connectors made out of Aluminum/Aluminum Alloy, the bolts shall be of 12 mm diameter, and for copper connectors the bolts shall be of 10 mm diameter.
- v. The clamps and connectors meant for ACSR and AAAC (525 sq.mm) shall have the same crimping dimensions. It shall be possible to use the same clamp/connector for ACSR or AAAC, as would be required, without any modification/change at site.
- vi. The length of bolt shall be chosen such that after fully tightening the nut and check-nut, minimum 5 (five) threads of the bolt shall project outside the nut/check-nut.
- vii. As an alternative to the various types of clamps and connectors detailed under 2.0 above, the Contractors may offer connectors of Power Fired Wedge Pressure Technology (PFWPT). However, the same needs to be specified in the Bid.
- viii. Connectors of PFWPT type shall meet the general requirements for various connections/joints as indicated in the relevant drawings.
- ix. PFWPT type connectors shall comprise of:

**a. Tapered 'C' - shaped spring member**

**b. Wedge for connecting solid/stranded conductor, along with handle, suitable for connection between:**

- Aluminium & Aluminium
  - Copper & Copper
  - Aluminium & Copper
  - Aluminium & Al. Alloy
  - Copper & Al. Alloy
  - Al. Alloy & Al. Alloy
- x. Components of the PFWPT type connectors shall be made of Aluminum Alloy suitably heat-treated to ensure that the required Mechanical & Electrical parameters are in line with ANS 1 specification no. C 119.4-1991. The connectors shall have 'self-cleaning' capability during application. The connector shall ensure stable and low contact resistance under varying load conditions and the thermal cycling effects.
- xi. The special tools and tackles required for installation of the PFWPT type connectors shall be identified in the offer. One set of these bolts and tackles shall be included in the scope of supply.
- xii. The Contractor shall furnish the following information in their bill of material:
- a. Availability of the PGWT connectors indigenously.
  - b. Unit rate of each item
  - c. Notwithstanding anything stated above, the final decision regarding acceptance of the type of clamps and connectors (conventional/PFWPT type) shall rest with JREDA

## **2.5. Structural Steel Work**

- i. The structural steelwork required for termination incoming 33 kV line/ Cable, equipment supports, lighting masts and for shielding towers together with all foundation bolts shall be included by the Bidder in its scope of work. The steel work shall be fabricated from galvanized structural sections. The height of structures for incoming line shall be as per the design developed by the Bidder and drawings submitted.
- ii. The incoming line gantry shall be designed on the basis of ACSR conductor/Cable considered in the design and also considering that TRANSCO/ DISCOM terminal tower will be located at a distance of not more than 100 meters from the incoming gantry at SPV power station switchyard. The Bidder shall take into account wind load, temperature variation etc. while designing the gantry structure. The column shall be provided with step bolts and anti-climbing devices.
- iii. The entire structural steel work shall conform to IS: 802. The Bidder shall furnish design calculations for approval by Owner before procuring the material.
- iv. The design of the switchyard towers, gantries and equipment structures shall also be designed in conformity with the standards followed by the Owner. Approval from the Owner also shall be obtained by the Bidder if required.

## **2.6.Hardware**

- i. Metal fittings of specified material for string hardware meant for power conductor and earth wire shall have excellent mechanical properties such as strength, toughness and high corrosion resistance. The suspension and tension clamps shall be made from aluminum alloy having high mechanical strength. Suspension and tension clamps offered shall be suitable for ACSR / AAAC conductor as per design.
- ii. All hooks, eyes, pins, bolts, suspension clamps and other fittings for attaching insulators to the tower or to the power conductor shall be so designed as to reduce (to a minimum) the damage to the conductor, insulator or the fitting arising from conductor vibration.
- iii. All drop-forged parts shall be free-from flaws, cracks, or other defects and shall be smooth, close-grained and of true forms and dimensions. all machined surfaces shall be true, smooth and well-finished. The thickness of all structural steel of Switchyard shall be minimum 80 microns measured at all points of the structure member when measured. No averaging is allowed. The gap between base plate of structural members and concrete top of foundation shall be filled with GP-2 grouting material of reputed make. The material of all J-bolts shall be of 8.8 Class.
- iv. All ferrous parts of hardware shall be galvanized in accordance with IS 2629. The galvanization shall withstand four dips of 1-minute duration each in copper-sulphate solution as per the test procedure laid down in the relevant ISS.
- v. The threads in nuts and tapped holes shall be cut after galvanizing, and shall be well-lubricated/greased. All other threads shall be cut before galvanizing.
- vi. Both the suspension and the tension hardware shall be of ball and socket type, and shall be with 'R' and 'W' type security clip of stainless steel or phosphor Bronze conforming to IS 2486. The tension clamps of both compression type and bolted type as shown in the relevant drawings shall be offered. Arcing horns shall be provided on the line side for both the suspension type and compression type hardware.
- vii. Size of each Danger Notice plates shall be 200 mm x 150 mm made of mild steel sheet and at least 2 mm thick, and vitreous enameled white on both sides and with inscription in signal red colors on front side as required. The inscriptions shall be in Hindi and English.

## **2.7.Fire Extinguishing System.**

- viii. The installation shall meet all applicable statutory requirements, safety regulations in terms of fire protection.
- ix. Liquefied CO<sub>2</sub> fire extinguisher shall be upright type of capacity 10 kg having IS: 2171. 7 IS: 10658 marked. The fire extinguisher shall be suitable for fighting fire of Oils, Solvents, Gases, Paints, Varnishes, Electrical Wiring, Live Machinery Fires, and All Flammable Liquid & Gas. Bidder shall provide portable fire extinguisher as given below:

<b>DCP Type (ABC type) (10 kg Cap)</b>	<b>CO<sub>2</sub> Type Hand 9 kg</b>	<b>Foam Type Hand 9 kg</b>
<b>1</b>	<b>1</b>	<b>1</b>

- x. The minimum 1 no. of fire extinguishers shall be required for each inverter rooms and as per CEA and safety guidelines required numbers of fire extinguisher shall be kept at switchyard and control room. For outdoor installations type AB fire extinguishers can be used and for all indoor applications type ABC fire extinguishers shall be used.
- xi. Sand bucket should be wall mounted made from at least 24 SWG sheet with bracket fixing on wall conforming to IS 2546.

**2.8.Lightening Protection for PV Array**

- i. The source of over voltage can be lightning or other atmospheric disturbance. Main aim of over voltage protection is to reduce the over voltage to a tolerable level before it reaches the PV or other sub-system components as per IEC 62305, IS: 2309 – 1989 (Reaffirmed – 2005), Edition 3.1 (2006-01).
- ii. Necessary foundation / anchoring for holding the lightning conductor in position to be made after giving due consideration to shadow on PV array, maximum wind speed and maintenance requirement at site in future.
- iii. The lightning conductor shall be earthed through flats and connected to the earth mats as per applicable Indian Standards with earth pits. Two earth pits shall be provided for each lightning arrester. Each lightning conductor shall be fitted with individual earth pit as per required Standards including accessories, and providing masonry Annexure with cast iron cover plate having locking arrangement, watering pipe using charcoal or coke and salt as required as per provisions of IS & Earth Resistance of Lightning System must be less than one (1) Ohm.
  - a. If necessary more numbers of lightning conductors may be provided. The Contractor is also free to provide franklin rod / Early Streamer type of lightning arrestors on the MMS structure designed in such a way not to cast shadow on the next raw of solar PV modules. The Contractor to submit necessary calculations based upon rolling sphere method for the Lightning protection system.

The Contractor shall submit the drawings and detailed specifications of the PV array lightning protection equipment to JREDA for approval before installation of system.

**2.9.AC Network**

- i. AC converted by the inverter is transmitted through the appropriate cables from the Inverter to appropriately sized Inverter transformer. In case of more than one Inverter transformer in a block, RMU shall be provided. Each individual block shall be connected to HT panel at MCR through AC cable. RMU panel should consist of adequate size indoor AC bus/ cable, which can handle the current and the voltage safely as per the relevant, IS standards. RMU panel should be equipped with adequate protection relays, fuses, annunciations and remote operating and controlling facility from the Main Control Room. Relevant national & international codes to be follows :-

**Table 0-3 Relevant National & International Code**

Sr.	Item	Relevant IS	Relevant IEC
1	Power transformer	IS 2026	IEC 76
2	Fittings & Accessories	IS 3639	
3	Climate Proofing	IS 3202	IEC 354
4	Loading of Transformer	IS 6600	IEC 296
5	Oil	IS 335	IEC 137
6	Bushings	IS 20650	IEC 144
7	Degree of Protection	IS 2147	IEC 76
8	Testing, Tolerances on guaranteed Particulars	IS 2026	IEC 76
9	Buchholz Relay	IS 3637	
10	Electrical Insulation	IS 1271	IEC 85

- ii. VCB/RMU panel shall be provided in Control Room. It shall have circuit breaker of suitable rating for connection and disconnection of String Inverter from grid. The busbar shall connect the AC distribution board to the transformer. It shall have provision to measure bus voltage, current and power of the transformer.
- iii. Bus-bars shall be of high conductivity Aluminium alloy or Copper of adequate size. The bus-bars shall be adequately supported by non-hygroscopic, non-combustible track resistant and high strength type polyester fibre glass moulded insulators. Separate supports shall be provided for each phase and neutral busbar. The bus-bars joints shall be provided with high tensile steel bolts, belleville washers and nuts, so as to ensure good contacts at the joints. The bus-bars shall be colour coded as per IS 375.
- iv. The Bidder shall submit the detailed specifications of the AC bus and panel in the Bid.
- v. The VCB/RMU panel with thermal over current and earth fault releases. The incomer shall be selected one size higher than the required rating as per Type 2 selection chart.
- vi. Removable gland plates with gaskets shall be provided in the cable alleys for glanding the power and control cables. The distance between the gland plate and the incomer terminals shall not be less than 450 mm.
- vii. The Contractor should submit theoretical design calculations and detailed explanations along with drawings shall be provided and approved by the Company.

**33kV SUBSTATION BLOCK:**

**2.10. Step-Up Transformer (Power Transformer/Inverter Duty Transformer)**

- i. The Contractor shall provide the complete turnkey design, supply, erection, testing and commissioning of transformers and transformer substation to first step-up the output of the inverter to 33 kV at the location of the inverter. Project to have 33kV Indoor/Outdoor Metering

Block. Each Step up Inverter Transformer must be connected with HV VCB/RMU Panel and cumulative of all the Step up Inverter Transformer must be connected with HV VCB/RMU panel for Metering. Provision of ABT meter to be provided at 33kV Four pole structure near evacuation point.

- ii. 3 phase, Oil Filled, 33 kV, 50 Hz, Power Transformers with min power rating 1.20 times of the selected inverter rating and associated Switchgear of approved make should be utilized. 33 KV transformers can be off-load tap change type. The transformers shall be suitable for outdoor installation with 3 phase 50 Hz 33 KV system and they should be suitable for service under fluctuations in supply voltage up to plus 10% to minus 15%. Maximum Three Winding transformer acceptable based upon Guaranteed Technical Parameter. For all category of transformers, similar rating of type test report is compulsory.

### General Standards for Transformers

IS: 2026 (Part 1 to 4)	Specifications for Power Transformer
IS: 2099	Bushings for alternating voltage above 1000 V
IS: 3639	Fittings and accessories for power transformer
IEC: 60076 (Part 1 to 5)	Specifications for Power Transformer
IS: 9921 Part 1 to 5	Alternating currents disconnectors (isolators) and earthing switches rating, design, construction, tests etc.
IS: 2705 Part 1 to 4 & IEC: 185	Current transformer
IS: 3156 Part 1 to 4	Potential Transformer
IS: 3070 part 1 to 3	Lightning arrestors
IS: 2544	Porcelain insulators for system above 1000 V
IS: 5350	Part III – post insulator units for systems greater than 1000 V
IS: 5621	Hollow Insulators for use in electrical equipment
IS: 5556	Serrated lock washers – specification
IEC: 186	Potential Transformer

- iii. Cumulative loss shall be as per IGBC guidelines. All electrical equipment and installation shall confirm to the latest Indian Electricity Rules as regards safety, earthing and other essential provisions specified for installation and operation of electrical plants.
- iv. Relevant national and international standards in this connection are mentioned in Table 5 – 6.
- v. All working parts, insofar as possible, are to be arranged for convenience of operation, inspection, lubrication and ease of replacement with minimum downtime. All parts of equipment or of duplicate equipment offered shall be interchangeable.
- vi. The quality of materials of construction and the workmanship of the finished products/ components shall be in accordance with the highest standard and practices adopted for the equipment covered by the specification.

- vii. All items of equipment and materials shall be thoroughly cleaned and painted in accordance with relevant Indian Standards. The finish paint shall be done with two coats of epoxy based final paint of colour Shade RAL 7032 of IS:5 for indoor equipment
- viii. Any fitting or accessories which may not have been specifically mentioned in the specification but which are usual or necessary in the equipment of similar plant or for efficient working of the plant shall be deemed to be included in the contract and shall be provided by the Contractor without extra charges. All plant and apparatus shall be complete in all details whether such details are mentioned in the specifications or not.
- ix. All equipment shall be designed for operation in tropical humid climate at the required capacity in an ambient air temperature of 50°C. Equipment shall be suitable for an ambient temperature of 50°C. Maximum relative humidity of 100% shall also be taken into consideration for design of equipment.
- x. The reference ambient temperatures for which the transformers are to be designed are as mentioned in below Table.
- xi. The rating and electrical characteristics of the MV / 33 kV Outdoor type transformer (typical) shall be as mentioned in below Table

**Table 0-4 Reference Weather Conditions for Transformer Design**

Sr.	Particulars	Specifications
1.	Maximum ambient temperature	50 degree C
2.	Maximum daily average ambient temp	40 degree C
3.	Maximum yearly weighted average ambient temp	40 degree C
4.	Minimum ambient air temperature: (Cooling medium shall be Air)	Minus 5 degree C
5.	CLIMATIC CONDITIONS :	
5.1	Maximum relative humidity	As per Site Conditions
5.2	Maximum wind speed	180 kmph

**Table 0-5 Rating and electrical characteristics of 33kV Power Transformer**

Sr.	Particulars	Inverter Transformer (Outdoor type)
1	Continuous kVA ratings	As per design
2	Type	Oil immersed
3	Frequency	50 Hz
4	Type of cooling	Oil Natural Air Natural
5	Winding Material	Electrolytic Copper
6	No. of phases	Three
7	Rating voltage H.V. side	33 kV
8	Highest System voltage on H.V. side	36 kV
9	Rated voltage on L.V. side	Output of solar inverter

10	Vector Group	Dyn5/ Dyn11/As per recommendation of Discom
11	Connections a) H.V. Winding b) L.V. winding	Delta Star
12	On load taps on H.V. Side (for H.V. Variation)	+ 5 to – 10.0 % (in steps of 2.5%)
13	Impedance voltage (%) as per IS 2026	4% to 8% OR as per Design
14	Minimum Creepage distance	25mm/ kV
15	Transformer connections	LV side – Bus Duct/ Busbar with weather proof Annexure, HV Side – Bushing with Annexure

### 2.11. Instrument Transformer

- i. The instrument transformers i.e. current and Potential Transformers shall be single phase transformer units and shall be supplied with a common marshalling box for a set of three single phase units. The tank as well as top metallic shall be hot dip galvanized or painted Grey color as per RAL 9002.
- ii. The instrument transformers shall be oil filled hermetically sealed units. The instrument transformers shall be provided with filling and drain plugs.
- iii. Polarity marks shall indelibly be marked on each instrument transformer and at the lead terminals at the associated terminal block. The insulators shall have cantilever strength of more than 500 kg.
- iv. Current Transformer, Voltage Transformer, Circuit Breaker and Relays should match –Local distribution JREDA requirements.

### 2.12. Current Transformer

- i. Current transformers may be either of the bushing type or wound type. The bushing types are normally accommodated within the transformer bushings and the wound types are invariably separately mounted. The location of the current transformer with respect to associated circuit breaker has an important bearing upon the protection scheme as well as layout of, substation. Current transformer class and ratio is determined by electrical protection, metering consideration.
- ii. Technical specifications – Current ratings, design, Temperature rise and testing etc. should be in accordance with IS: 2705 (part I to IV)

### Type and Rating

- a. The current transformer should be of outdoor/ indoor type, single phase, oil immersed, self-cooled and suitable for operation in 3 phase solidly grounded system.
- b. Each current transformer should have the following particulars under the site conditions for the system under design (typical values for 33 kV systems are given).
- c. General Parameters: 11/33kV CT.

- d. Each current transformer should have the following particulars under the site conditions for the system under design (typical values for 11/33kV system are given).

**Table 0-6 General parameters for 33 kV CT**

Sr.	Particulars	Details
1	Highest System Voltage (Um)	36 kV rms
2	Rated frequency	50 Hz
3	System Neutral Earthing	Effective earthed
4	Installation	Outdoor/indoor(IP 65)
5	Rated short <b>time</b> thermal current	25 kA for 1 sec or appropriate thermal current as per design calculations
6	Rated dynamic current	63 kA (Peak) appropriate dynamic current as per design calculations
7	Rated min power frequency withstand voltage (rms value)	28/70 kV
8	Rated lightning impulse withstand voltage (peak value)	70/170 kV
9		
10	Minimum Creepage distance	25 mm/kV
11	Temperature rise	As per -IS 2705/1992
12	Type of insulation	Class A
13	Number of cores	Two (2) with One (1) protection core and one (1) metering core of accuracy 0.5 class
14	CT secondary current	Protection cores – 1 Amp. Metering Core – 1 Amp (With Highest Accuracy Class)
15	Number of terminals in marshalling box	All terminals of control circuits wired up to marshalling box plus 20 terminals spare
16	CT ratio & Rated VA Burden, short time thermal rating ,class of accuracy	Minimum burden required : 1. Metering core – 40 VA 2. Protection core – 10 VA

**2.13. General Parameters of 33 kV PT**

The Bidder has to furnish the specifications of 33kV PT with the Bid.

**Table 0-7 General parameters for 33 kV PT**

Sr.	Particulars	Details
1	Highest system voltage (Um)	36 kV
2	System neutral earthing	effective earthed
3	Installation	Outdoor (IP 65)
4	System fault level	Appropriate
5	Rated min power frequency withstand voltage (rms value)	28/70 kV

6	Rated lightning impulse withstand voltage (peak value)	70/170 kV
7	Standard reference range of frequencies for which the accuracy are valid	96% to 102% for protection and 99% to 101% for measurement
8	Rated voltage factor	1.2 continuous & 1.9 for 30 sec
9	Class of Accuracy	0.5 / 3P, IS3156/1992
10	Minimum Creepage distance	25 mm/kV
11	Stray capacitance and stray conductance of LV terminal over entire carrier frequency range	As per IEC:358
12	One Minute Power frequency Withstand voltage for secondary winding	3 kV rms
13	Temp.rise over an ambient temp. of 50 deg. C	As per IS 3156/1992
14	Number of terminals in control spare.	All terminals of control circuits wired Cabinet up to marshalling box plus 10 terminals
15	Rated total thermal burden	350 VA
16	Number of cores	2 (two) – 1 for protection and one for metering with 0.5 class accuracy.
17	Rated Output, insulation level, transformation ratio, rated voltage factor	Should be provided by the Contractor.

#### 2.14. Circuit Breaker

- i. The circuit breakers shall be capable of rapid and smooth interruption of currents under all conditions completely suppressing all undesirable phenomena even under the most severe and persistent short circuit conditions or when interrupting small currents or leading or lagging reactive currents. The circuit breakers shall be 'Restrike-Free' under all operating conditions. The details of any device incorporated to limit or control the rate of rise of restriking voltage across, the circuit breaker contacts shall be stated. The over voltage across, the circuit breaker contacts shall be stated. The over voltage caused by circuit breaker while switching inductive or capacitive loads shall not exceed 2.5 times the highest phase to neutral voltage. The actual make and break times for the circuit breakers throughout the ranges of their operating duties shall be stated in the offer and guaranteed.
- ii. The arc quenching chambers shall have devices to ensure almost uniform distribution of voltage across the interrupters.
- iii. Appropriate & adequate Capacity 415V AC indoor air Circuit Breaker as per the IEC 60898 / IEC 62271 – 100 or equivalent Indian Standards along with control circuit and protection relay

- circuit, fuses, annunciators and remote operating and controlling facility from the Main Control Room.
- iv. Circuit breaker shall be C2/M1 class under all duty conditions and shall be capable of performing their duties without opening resistor. The circuit breaker shall meet the duty requirement of any type of fault or fault location and shall be suitable for line charging and dropping when used on 6 kV effectively grounded or ungrounded systems and perform make and break operations as per the stipulated duty cycles satisfactorily.
  - v. The circuit breaker shall be capable for breaking the steady & transient magnetizing current corresponding to 11/33 kV transformers. It shall also be capable of breaking line charging currents as per IEC- 62271-100 with a voltage factor of 1.4.
  - vi. The rated transient recovery voltage for terminal fault and short line faults shall be as per IEC: 62271-100.
  - vii. The Bidder shall indicate in the Bid, the noise level of breaker at distance of 50 to 150 m from base of the breaker.
  - viii. The Bidder may note that total break time of the breaker shall not be exceeded under any duty conditions specified such as with the combined variation of the trip coil voltage, pneumatic pressure etc. While furnishing the proof of the total break time of complete circuit breaker, the Bidder may specifically bring out the effect of non-simultaneity between same pole and poles and show how it is covered in the guaranteed total break time.
  - ix. While furnishing particulars regarding the D.C. component of the circuit breaker, the Bidder shall note that IEC-62271-100 requires that this value should correspond to the guaranteed minimum opening time under any condition of operation.
  - x. The critical current which gives the longest arc duration at lock out pressure of extinguishing medium and the duration shall be indicated.
  - xi. All the duty requirements specified above shall be provided with the support of adequate test reports.
  - xii. Circuit breaker shall be Vacuum type with electrically spring charged mechanism. The operating mechanism shall be anti-pumping and trip free (as per IEC definition) electrically under every method of closing. The mechanism of the breaker shall be such that the position of the breaker is maintained even after the leakage of operating media and / or gas. The circuit breaker shall be able to perform the duty cycle without any interruption.
  - xiii. Electrical tripping shall be performed by shunt trip coil. Provision shall also be made for local electrical control. 'Local / remote' selector switch and close & trip push buttons shall be provided in the breaker central control cabinet. Remote located push buttons and indicating lamps shall also be provided. The VCB coil DC supply through appropriately rated battery bank and charger to be supplied by the Contractor.

- xiv. Operating mechanism and all accessories shall be in local control cabinet. A central control cabinet for the three poles of the breaker shall be provided along with supply of necessary tubing, cables, etc.
- xv. Mounting and supporting structure for Circuit Breaker. The circuit breakers should be self-supporting type. However, if necessary for the purpose of minimum ground clearance the circuit breakers should be mounted on raised steel structures which should be included in the scope of supply of circuit breaker.
- xvi. Following information and data for design of foundations from the supplier of the circuit breaker be obtained.
- xvii. Dead weight per pole for complete circuit breaker
  - a. Static bending moments above the feet of each pole and for complete circuit breaker.
  - b. Static shear force at the foot of each pole and for complete circuit breaker
  - c. Maximum height of the steel supporting structure
  - d. Maximum diameter of the pole
  - e. Maximum horizontal force acting at upper terminal of each pole due to impact of closing/opening of the circuit breaker
  - f. Max. Impact loading in terms of equivalent static load both compression and upward due to opening/closing of the breakers. It shall be clearly stated whether these forces shall act simultaneously or at different timing.
  - g. No. of steel supporting columns provided for mounting the equipment.
  - h. The above data should represent static reactions for the worst windage or operation conditions. Circuit breakers whether of self-supporting type or on raised steel structure should ensure minimum sectional clearance (say 3500 mm for 33 kV).
  - i. Necessary connecting materials such as clamps, bolts, nuts, washers etc. and fixing bolts for mounting the equipment on the supporting structures wherever required should be obtained from the circuit breaker supplier.

**Applicable Standards:** The materials shall conform in all respects to the relevant Indian Standard Specifications/ IEC Standards, with latest amendments indicated below in Table 5 – 11.

**Table 0-8 Applicable Standards for Circuit Breakers**

Indian Standard	Title	International & Internationally recognized standard
ISS-13118/1991	General requirements for Circuit breakers for voltage above 1000 V	IEC 62271-100-1/2001
ISS-2705/1992	<b>2.15.</b> Current Transformers	

ISS-2099/1986	Bushings for alternating voltages above 1000 V	
ISS-2633/1964	Methods of testing uniformity of coating of zinc coated articles	
ISS-3231/1986	Electrical relays for power system protection	
ISS-1248/1983	Specification for Ammeters & Voltmeters	
ISS-335/1983	New insulating oils Electrical Clearances	IEC 71 (For oils in CTs)
ISS-2147/1962	Degree of protection provided by Annexures for low voltage switchgear & control gear	

- i. **General Parameters of Circuit Breaker:** General parameters: Outdoor/ Indoor Vacuum type Circuit Breaker.

**Table 0-9 General Parameters for Vacuum Type Circuit Breakers**

Sr.	Particulars	Details
1	Type of circuit breaker	Vacuum type
2	Highest System Voltage	36 kV
3	Rated operating voltage	33 kV
4	Rated frequency	50 Hz (+3% to -5%)
5	Number of poles	Three (3)
6	Rated/minimum power frequency Withstand voltage	70 kV
7	Rated lightning impulse Withstand voltage	170 kV
8	Minimum Creepage distance	25mm/ kV
9	Rated operating duty cycle	0 - 0.3 sec. - CO – 3 min. – CO
10	Rated line charging breaking	As per IEC
11	Reclosing	Single and three phase high speed auto reclosing
12	Maximum fault level	25 kA (rms) for 1 sec or appropriate design.
13	Auxiliary contacts	As required plus 6NO and 6NC contacts per pole as spare.
14	Noise level	Maximum 140dB at 50m distance from base of circuit breaker
15	Seismic acceleration	g horizontal

- ii. General Parameters of SF6 Insulated Ring Main Unit (RMU):

**Table 0-10 General Parameters for SF6 Type RMU**

Sr.	Particulars	Details
1	Type of Ring Main Unit	Metal enclosed, compact module, panel type, IEC 62271-200
2	Highest System Voltage	36 kV
3	Rated operating voltage	33kV
4	Rated frequency	50 Hz (+3% to -5%)
5	Number of poles	Three (3)
6	Rated/minimum power frequency Withstand voltage	70 kV
7	Rated lightning impulse Withstand voltage	170 kV
8	Rated Current Busbar	630A
9.	Insulation Gas	SF <sub>6</sub>
10	Minimum Creepage distance	25mm/ kV
11	Rated operating duty cycle	0 - 0.3 sec. - CO – 3 min. – CO
12	Rated line charging breaking	As per IEC
13	Reclosing	Single and three phase high speed auto reclosing
14	Maximum fault level	21 kA (rms) for 1 sec. Or appropriate as per design
15	Rated Making Capacity	52 kA
16	Rated Breaking Capacity	21 kA
17	Auxiliary contacts	As required plus 6NO and 6NC contacts per pole as spare.
18	Noise level	Maximum 140dB at 50m distance from base of circuit breaker

iii. Co-ordination of rated voltages, short circuit breaking current and rated normal current for guidance as per IS 13118 for rated voltage 33 kV and above as commonly used.

iv. Circuit Breaker protection against

- Over Current
- Earth fault
- Under voltage & over voltage protection
- Under frequency & over frequency
- SF6 gas pressure low (where applicable)
- DC supply failure

**2.16. Protective Relays**

i. The Solar PV system and the associated power evacuation system interconnections should be protected as per IEC 61727 Ed.2, norms. Over current relays, reverse power relays and earth

fault relays have to be essentially provided as per technical requirements. All relay should be numerical type & should be remote operating and controlling facility from the control room.

- ii. The numerical relays shall have RS 485 port for communication.
- iii. The operating voltage of the relays shall be 110 V DC/220 V DC as per battery bank rating.
- iv. Detailed Design calculations shall be provided on fault power computations and the philosophy of protective relaying with respect to short circuit kA calculations. Design, drawing and model of protection relay shall be approved by the Company/Electricity Authority.

#### **2.17. Earthing for PV Array**

- i. The photovoltaic modules, BOS and other components of power plant requires adequate earthing for protecting against any serious faults as guided by IEC 60364.
- ii. The earthing system shall be designed with consideration of the earth resistivity of the project area. The earth resistivity values shall be measured prior to designing the earthing system. Unless otherwise specified, earthing system shall be in accordance with IS: 3043 and IEEE 80, Indian Electricity Rules, Codes of practice and regulations existing in the location where the system is being installed.
- iii. The permissible system fault power level at 33 kV also shall be kept in consideration while designing the earthing system. Each array structure of the PV yard, LT power system, earthing grid for switchyard ,all electrical equipment ,control room ,PCU, All junction boxes, ACDB& DCDB ,all motors and pumps etc .shall be grounded properly as per IS 3043 - 1987. All metal casing / shielding of the plant shall be thoroughly grounded in accordance with Indian electricity act / IE Rules.
- iv. The earthing for array and LT power system shall be made of 3.0 m long 40 mm diameter perforated Cu/GI/ chemical compound filled, double walled earthing electrodes including accessories, and providing masonry Annexure with cast iron cover plate having pad-locking arrangement, chemical compound mix as required as per provisions of IS: 3043.
- v. Necessary provision shall be made for bolted isolating joints of each earthing pit for periodic checking of earth resistance.
- vi. Each string/ array and MMS of the plant shall be grounded properly. The array structures are to be connected to earth pits as per IS standards. Necessary provision shall be made for bolted isolating joints of each earthing pit for periodic checking of earth resistance.
- vii. The complete earthing system shall be mechanically & electrically connected to provide independent return to earth.
- viii. For each earth pit, a necessary test point shall be provided.

- ix. In compliance to Rule 11 and 61 of Indian Electricity Rules, 1956 (as amended up to date), all non-current carrying metal parts shall be earthed with two separate and distinct earth continuity conductors to an efficient earth electrode.
- x. The Contractor should submit the earthing system design calculations along with the system layout for the Company’s approval prior to the installation of the system
- xi. Unless otherwise specified, the earthing system primary and secondary grid conductors, equipment connections shall be constructed with galvanized iron flat. However the earthing of transformer neutrals, plc and inverter terminals and electronic earthing shall be provided using copper earthing conductor only.
- xii. Earthing Mesh is to prepared and installed in entire power plant.

**2.18. Lightning Protection for PV Plant & Earthing**

- i. The source of over voltage can be lightning or other atmospheric disturbance. Main aim of over voltage protection is to reduce the over voltage to a tolerable level before it reaches the PV or other sub-system components as per IEC 60099 / IS: 2309 – 1989 (Reaffirmed – 2005), Edition 3.1 (2006-01). Lightning Protection System required for Solar PV Plant, Inverter Room, and Substation Structure & Control Room within the EPC scope of work. The intent of specification can be conventional as per IS : 2309 or can be Early Streamer Emission Type depending upon Area, Protected Equipment & Technical feasibility. Necessary concrete foundation for holding the lightning conductor in position to be made after giving due consideration to shadow on PV array, maximum wind speed and maintenance requirement at site in future. We recommended going with Early Stream Emission Air Terminal Technology as per NFC 17-102 / IEC 62305-2. Level of Protection must be defining as per Rolling Sphere Method LPL-I, LPL-II, LPL-III & LPL-IV where the radius shall be of 20mtr, 30mtr, 45mtr & 60mtr respectively.
- ii.  $R_p(h)$  : Protection radius at a given height (h)  $R_p(h) = \sqrt{2rh - h^2 + \Delta(2r + \Delta)}$  (for  $h \geq 5$  m) For  $h < 5$  m, refer to the table below h : Height of the OPR tip above the surface(s) to be protected r(m) : Standardized striking distance  $\Delta(m) = 106 .\Delta T$  (OPR efficiency)

OPR radius of protection

Protection level	I (r = 20 m)			II (r = 30 m)			III (r = 45 m)			IV (r = 60 m)		
	OPR 30	OPR 45	OPR 60	OPR 30	OPR 45	OPR 60	OPR 30	OPR 45	OPR 60	OPR 30	OPR 45	OPR 60
<b>h (m)</b>	<b>Radius of protection Rp (m)</b>											
2	19	25	31	22	28	35	25	32	39	28	36	43
3	29	38	47	33	42	52	38	48	58	43	57	64
4	38	51	63	44	57	69	51	65	78	57	72	85
5	48	63	79	55	71	86	63	81	97	71	89	107
6	48	63	79	55	71	87	64	81	97	72	90	107
8	49	64	79	56	72	87	65	82	98	73	91	108
10	49	64	79	57	72	88	66	83	99	75	92	109
15	50	65	80	58	73	89	69	85	101	78	95	111
20	50	65	80	59	74	89	71	86	102	81	97	113
45	43	65	76	58	75	89	75	90	105	89	104	119
50	40	65	74	57	75	88	75	90	105	89	104	120
55	36	65	72	55	75	86	74	90	105	90	105	120
60	30	65	69	52	75	85	73	90	104	90	105	120

- ii. The lightning conductor shall be earthed through flats and connected to the earth mats as per applicable Indian Standards with earth pits. Each lightning conductor shall be fitted with individual earth pit as per required Standards including accessories, and providing masonry Annexure with cast iron cover plate having locking arrangement, chemical compound as per provisions of IS.

- iii. If necessary more numbers of lightning conductors may be provided as per design calculation
- iv. The Contractor shall submit the drawings and detailed specifications of the PV array lightning protection equipment.
- v. The design, manufacture, inspection, testing and performance of Lightning Arrester shall comply with all currently applicable statutes, safety codes, provision of latest Indian Electricity Act, Indian Electricity Rules and Regulations of Statutory Authorities.
- vi. Contractor shall provide dedicated two earth pits for Lightning Arrestor as per relevant IS standard.

#### **2.19. Isolators cum Earthing Switches, Contacts, Insulators, Busbars**

- i. This specification covers design, manufacture, testing and supply of. Manually operated 33 KV, 800 Amps Upright mounting type with manually operated with earth switch Isolators. The Isolators and Isolator-cum-Earthing Switched shall comply with the requirements of the IS: 9921 and IEC: 129 (latest edition) except specified herein. The Insulators shall comply with the requirements of IS : 2544 and IEC : 168-1988 (latest edition) for 33 kV pole mounted structure wherever required. 33kV pole mounted structure would be supplied, installed and commissioned by the Contractor wherever required.
- ii. The isolator shall be of the manual operated type with earthing switches and shall complete with all parts and accessories including insulator operating rods, mounting attachments, necessary for their efficient operation. The equipment shall confirm in all respect to high standards of engineering Equipment shall capable of performing in continuous commercial operation up to the suppliers guarantee in a manner acceptable to the client, The equipment offered shall be complete with all components necessary for its effective and trouble free operation along with associated equipment's, interlock, protection schemes, etc. Such components shall be deemed to be within the scope of the Contractor's supply irrespective of whether those are specifically brought out in this specification or not. All similar parts particularly removable ones shall be interchangeable.
- iii. Each pole shall have three Pedestal type of Insulator's stacks. Necessary arrangements shall be provided for proper alignment of the contacts. Gange operated links shall be so designed that all phases shall make and break simultaneously. The design of Isolators and Isolator-cum-Earthing Switches shall be provided for positive control of blades in all positions with minimum mechanical stress on the Insulators. Fixed guides shall be so provided that proper setting of contacts shall be obtained, when a blade is out of alignment even by 25mm in either direction. All movable parts which may be in current path shall be shunted by flexible copper conductor of adequate cross-section and capacity, which shall be furnished under bill of material.

#### **2.20. Service Condition:**

The 33 kV triple pole air break isolators are intended to be used primarily for sectionalizing 33 kV UG cable portion of the line with 33 kV overhead portion of the line.

Isolator shall confirm IS: 9921(Part 1 to 4) & IEC 600 - 129 "alternating current disconnects (Isolators) and earthing switches", and IS 9921 (Part-I to IV) "Specification for alternating current disconnects (isolators) and earthing switches for voltages above 1000V"

- a. The moving & fixed contacts shall be made of hard drawn electrolytic grade copper strips and shall be heavy duty self-aligning & high pressure type preferably which applies pressure to the contact surfaces after the blades are fully closed and release the pressure before they start to open. High pressure type contacts shall wipe the contact surfaces, while opening and closing. The contacts shall be so designed that wiping, action shall not cause securing or abrasion on the contact surfaces. The wiping action shall be sufficient to remove oxide film, formed during the operation of the switches. The pressure shall be developed by rotation of the entire blade.
- b. The temperature rise of contacts due to the flow of rated short circuit current for a period of 3 seconds shall not cause any annealing or welding of contacts.
- c. The moving contacts, if provided, shall close first and open last so that no damage is caused due to arcing whatever to the main contacts. The Successful Bidder shall give full details of such contacts with necessary drawings.
- d. The arcing contacts, if provided shall close first and open last so that no damage is caused due to arcing whatever to the main contacts. The Contractor shall give full details of such contacts with necessary drawings.
- e. The female contact and its tensioning by spring shall be such that there will, always, be a positive contact with adequate pressure to give enough contact surface for the passing of current. The springs provided should not go out of alignment or get entangled with the male contact during operation. The details of springs shall be furnished on the G.A. drawing.

## **2.21. Insulators**

The isolator shall be provided with solid core insulators.

- i. These shall be of stacking type to be used. The dimensions and other parameters unless otherwise specified shall generally conform to IS - 5350-Part-11 & IEC 273.
- ii. The cylindrical type post insulators shall be of solid core type. Insulators of similar type shall be interchangeable. The mechanical strength class for outdoor cylindrical post insulators shall be of strength class 6, corresponding mechanical strength in tension, compression and torsional shall be as per IS: 53550 Part - II. When operated at maximum system voltage, there shall be no electrical discharge. Shielding rings, if necessary shall be provided.
- iii. The parameters of the insulators required shall conform to IS: 0350 - Part - II - 1973 or IEC 273.
- iv. The cylindrical post insulators shall consist of single unit only.

- v. The insulator shall be provided with a completely galvanized steel base designed for mounting on the support. The base and mounting arrangement shall be such that the insulator shall be rigid and self-supporting and no guying or cross bracing between phase shall be necessary.

#### **2.22. Porcelain of the insulator:**

- a. The porcelain used for the manufacture of the insulators shall be homogenous, free from laminations and other flaws or imperfections that might effect the mechanical or dielectric quality and shall be thorough vitrified, tough and impervious to moisture. The glazing of the porcelain shall be uniform brown colour, with a smooth surface arranged to shade away rain water and free from blisters, burns and other similar defects. Insulators shall be interchangeable.
- b. The porcelain and metal parts shall be assembled in such a manner and with such materials that any differential thermal expansion between the metal and porcelain parts throughout the operating temperature range will not loosen the parts or electrical strength or rigidity. The assembly shall not have excessive concentration of electrical stress in any section or across leakage surfaces. The cement used shall not give rise to chemical reaction with metal fittings. The insulator shall be suitable for water washing by rains or artificial means in service conditions. Further the insulators to be supplied shall be of high- quality and should not result in mismatch and misalignment of stacks during erection and operation.
- c. Each cap shall be of a high grade cast iron or malleable steel casting or steel forging. Cap and base insulators shall be interchangeable with each other. The insulator shall conform to the requirement of the latest edition of IS: 2544, or any other equivalent standard. The Bidder should furnish the characteristics of insulators in the Bid.

#### **2.23. Busbars**

- i. The outdoor bus-bars and equipment connections shall be with ACSR conductor (Panther / suitable size as per design).
- ii. The bus-bars and the connection jumpers shall be supported on post insulators wherever required.
- iii. The ACSR bus bars are an underground system of wires strung between two supporting structures and supported by strain type insulators. The stringing tension may be limited to 500-900 kg. depending upon the size of the conductor used. These types of bus bars are suitable for earthquake prone areas.
- iv. Bus bar Material – The materials in common use for bus bars and connections of the strain type are ACSR conductor.
- v. Since aluminum oxides rapidly great care is necessary in making connections. In the case of long spans expansion joints should be provided to avoid strain on the supporting insulators due to thermal expansion or contraction of pipe.

- vi. The bus bar sizes should meet the electrical and mechanical requirements of the specific application for which they are chosen.
- vii. The isolator shall be provided with padlocking device to permit locking of the isolator in both fully open and fully closed positions.

#### **2.24. Control & Relay Panel Specifications**

- i. The control & relay panel shall be free standing, simplex type, floor mounting type, fabricated from 2 mm thick MS sheet for main Annexure and 1.6 mm thick MS sheet for internals and partitions. The main Annexure shall be mounted on a base frame fabricated out of 100x50 ISMC mild steel section.
- ii. The Annexure external finish color shade shall be decided by the Company, The internal surface shall have a glossy white finish all over.
- iii. The control & relay panel shall contain the following metering and protection devices:
  - Metering, Indications & Controls
  - Ammeter – 0 – ..... A
  - Ammeter selector switch
  - Voltmeter – 0 – 12/36 kV
  - Voltmeter selector switch
  - Load manager to display the following parameters : MW, MVA, MVArh, MVAr Cos Ø, Hz,
  - Indication lamps for R, Y, B phases, Breaker ‘ON’ (R), Breaker ‘OFF’ (G), Breaker ‘TRIP’ (A), Spring charged (W), Trip Circuit Healthy (B)
  - TNC switch, spring return to neutral position shall be provided for circuit breaker operation.
  - Local / Remote selection switch for circuit breaker operation
  - Semaphore indicators (LED type) for CB and Isolator ‘Open’ & ‘Close’ positions
  - Mimic diagram for the 33 kV systems with aluminum strips and ‘ON’ ‘OFF’ indications for isolators

#### **2.25. Low Voltage Switchgear**

- i. This specification is for the 415V TP&N Power Control Centre (PCC).
- ii. The PCC shall be rated for the maximum output of the supply transformer feeding the system.
- iii. The short circuit withstand rating (1 sec) at rated voltage of the switchgear shall be minimum of 20 kA (rms) and corresponding dynamic rating shall be 50 kA (peak).
- iv. The configuration of the PCCs shall be as per the Single Line Diagram of the system.

#### **2.26. Execution**

- i. Single front / compartmentalized, modular design, degree of protection IP52 with provision of extension on both sides.
- ii. Incomer feeders: mains incomer - Electrically operated draw out type Air Circuit Breakers (ACBs).

- iii. Outgoing feeders : Electrically operated draw out type Air Circuit Breakers (ACBs) / Moulded Case Circuit Breakers (MCCBs)
- iv. The color finish shade of switchgear Annexure for interior shall be glossy white & for exterior it shall be light grey, semi glossy shade 631 of IS: 5. If a different exterior shade is desired by the PURCHASER, the same shall be intimated to the supplier.
- v. The PCC shall be fabricated out of CRGO sheet steel; 2 mm thick for the outer shall all-round. The internal walls and separators shall be of 1.6 mm thick CRGO sheet steel.
- vi. The gland plates shall be 3 mm thick.

#### **2.27. Control & Relay Panel Specifications for 415 V TP&N Power Control Centre (PCC)**

- i. This specification is for the 415V TP&N Power Control Centre (PCC).
- ii. The PCC shall be rated for the maximum output of the supply transformer feeding the system. The short circuit withstand rating (1 sec) at rated voltage of the switchgear shall be minimum of 20 kA (rms) and corresponding dynamic rating shall be 50 kA (peak)
- iii. The configuration of the PCCs shall be as per the Single Line Diagram of the system.

#### **Execution**

##### Power Control Centers (Construction)

- a. Single front / compartmentalized, modular design, degree of protection IP52 with provision of extension on both sides.
- b. Incomer feeders: mains incomer - Electrically operated draw out type Air Circuit Breakers (ACBs).
- c. Outgoing feeders : Electrically operated draw out type Air Circuit Breakers (ACBs) / Moulded Case Circuit Breakers (MCCBs)
- d. The colour finish shade of switchgear Annexure for interior shall be glossy white & for exterior it shall be light grey, RAL 7032 of IS: 5. If a different exterior shade is desired by the PURCHASER, the same shall be intimated to the supplier.
- e. The PCC shall be fabricated out of CRGO sheet steel; 2 mm thick for the outer shall all-round. The internal walls and separators shall be of 1.6 mm thick CRGO sheet steel
- f. The gland plates shall be 3 mm thick

#### **Control Circuit**

- a. Control supply for breaker closing / tripping - 110V DC
- b. Air Circuit Breaker spring charge motor – 240 V AC, 1 phase
- c. Moulded Case Circuit Breakers – 240 V AC, 1 phase
- d. Indications, annunciation – 110V DC
- e. Space heater, sockets, etc. – 240 V AC, 1 phase

#### **Busbar and Cable Cavity**

- a. The material for main bus bars and tap off bus bars shall be electrolytic grade aluminum with HR PVC sleeved insulation

- b. Bus bars shall be suitable for short circuit rating and current suitable for all connected load.
- c. Bottom cable entry for incoming and outgoing cables
- d. A suitable gland plate shall be supplied for termination of power, control and instrumentation cables.
- e. Whenever feeders are housed in multi-tier configuration, these tiers shall be segregated by sheet metal barriers

**2.28. Control Room Electrical Wiring**

- i. Electrification of building shall be carried out as per IS 732-1989, IS 46481968 and other relevant standards. Suitable AC Distribution Board should be designed to Supply AC power in Control room.
- ii. Control room AC distribution Board theoretical design, calculations and detailed explanations along with drawing shall be provided and approved by JREDA.

**2.29. Auxiliary Power Supply**

- i. The Contractor shall install a separate 33 kV / 415 V step down transformer to supply power for internal equipment such as power for control equipment, area lighting, water pumps, and conference room fixtures, control room lighting and air-condition, etc.
- ii. This auxiliary power should be utilized directly from the internal connection before the metering point of the solar PV Plant. A separate meter can be installed for auxiliary consumption just for internal accounting purpose.

**2.30. DC Battery & Charger**

- i. Adequate capacity DC battery Bank should be provided for emergency control supply of inverters, control / protection system & emergency lighting. A appropriate capacity battery charger with relevant IS/IEC standards & protection and automatic change over system should be provided to charge the battery bank along with relay circuit, fuses, annunciations and remote operating and controlling facility from the Main Control Room.
- ii. A DC power supply Distribution panel/board should be supplied along with the Charger as per relevant IS standards. Control room DC Battery Bank & DC supply system theoretical design, calculations and detailed explanations along with drawing shall be provided and approved by JREDA.
- iii. DC Batteries the batteries shall have the following specifications
  - a. Type : Sealed LA type, storage battery
  - b. Rating : 110 V D.C., Minimum 80 Ah at 8 Hour rate of discharge
  - c. Standard : IS 1651 – 1979 ; performance as per IS 8702
  - d. Container : Plastic Resin, ABS or PP
  - e. Terminal Post : Designed suitably to accommodate external bolted connections
- iv. The battery shall be provided with epoxy paint coated exhaust fan for removal of gasses released from the battery cells.

- v. The data sheet for the battery shall be submitted along with the Bid for evaluation.

### **2.31. Earthing**

- i. Earthing bus bar shall be terminated at both ends of the switchgear to suit the connections to outside earthing conductor. All components inside the module are required to be earthed individually and are to be looped and connected to the horizontal earth bus.

#### **Terminals**

- a. CT circuit - Isolating link type terminals with shorting facility
- b. PT circuit – clip on type terminals
- c. Spare contacts shall be wired up to terminal block. 10% spare terminals shall be provided for each module

### **2.32. Specific Requirements**

1. All ACBs shall be 4 pole, electrically operated, draw-out type, with closing coil, spring charge motor, trip coil, TNC switch for close and trip, manual closing and tripping push buttons, door I/L, test and service position micro switches, emergency P.B., safety shutters, etc. The circuit breaker shall be provided with anti-pumping feature.
2. ACBs shall be complete with microprocessor release and shall be provided with over current, short circuit and earth fault protections.
3. Minimum 10% spare feeders of each rating shall be provided in the switchgear.
4. All current transformers shall have 5/1A secondary and all meters shall be suitable for 5/1 A operation.
5. All indicating lamps shall be of LED cluster type. ACB feeders shall be provided with ON, OFF, AUTOTRIP, SPRING CHARGED, TEST, SERVICE, TRIP CIRCUIT HEALTHY indications
6. All indicating instruments shall be flush mounting, Digital, 96 sq.mm size.
7. Window annunciator with hooter and accept, test, reset button shall be provided. Necessary auxiliary relays for contact multiplication shall be provided in the panel.
8. The maximum temperature of the bus bars, droppers and contacts at continuous current rating under site reference ambient temperature of 50° C shall not exceed 105° C.  
Instrumentation: Switchgear instrumentation shall be provided as follows:
  - a. Mains Incomer – Voltmeter with selector switch
  - b. Ammeter with selector switch
  - c. Power Factor meter
  - d. Frequency meter
  - e. TVM + MD meter
  - f. Potential indicating lamps
  - g. Outgoing Feeders
  - h. Ammeter with selector switch on all feeders

### **2.33. General Technical Specifications of Control Panel**

- i. The panel shall be self-supporting, free standing, floor mounted, modular type with construction having degree of protection of IP 54 as per IS 2147.
- ii. The panel shall be fabricated from 14 SWG CRCA sheet steel for frame & load bearing surfaces. Partitions may be fabricated from 16 SWG CRCA if no components are mounted on them.
- iii. The panel shall be painted with 2 coats of primer after pre-treatment and 2 coats of Polyurethane / epoxy paint with shade as decided by the Company.
- iv. Stiffeners shall be provided at corners & between modules to make panel rugged. The stiffeners will necessarily be required for relay compartments or doors where heavy components are mounted.
- v. The openable covers shall be provided with lift off type hinges, quarter turn door locks and flexible copper wire for earth connection.
- vi. The panel shall be dust and vermin proof. Synthetic or neoprene gaskets shall be provided at all openings.
- vii. The panel shall be of dead front construction suitable for front operated and back maintained functioning.
- viii. Panel shall be provided with fl. lamp of 20 w capacity operated by door operated limit switch. Panel shall also have space heaters and thermostat arrangement.
- ix. Panel shall be provided with 3 pin switch socket combined unit of 5 Amp capacity.
- x. Lifting hooks shall be provided at the top of the panel.
- xi. The hardware components used in the panel shall be hot dipped galvanized.
- xii. The control components shall be fixed on mounting plate by drilling & tapping.
- xiii. Aluminium anodized legend plates shall be provided for all the components. For components mounted on front face, legend plate from inside shall also be provided.
- xiv. Pre-treatment by 7 tank process shall be done before painting / powder coating the panel.
- xv. Panel shall have provision of drawing pocket.
- xvi. The panel shall be designed to ensure maximum safety during operation inspection, connection of cables and maintenance. Inside panel, checking and removal of components shall be possible without disturbing other units.
- xvii. Cable entries will be from bottom. The opening of cable entry shall be covered by 3 mm thick gland plates.
- xviii. The panel shall be provided with all necessary components / devices and instruments as per the enclosed schematic diagram and functional requirements.
- xix. The components such as protective relays, auxiliary relays, push buttons, switches, instruments shall be flush mounted on the front side of a panel.
- xx. The control wiring shall be done with PVC insulated flexible copper wire. For CT secondary circuits 2.5 sq.mm. wire shall be used. For control wiring 1.5 sq.mm. wire shall be used.
- xxi. Earthing bus-bar of suitable cross section shall be provided throughout the length of panel.
- xxii. The panel shall be fully wired all the terminals shall be brought out for cable connections. 10% spare terminals shall be provided on each terminal block. Separate

- terminal block shall be provided for different voltages. All wire shall have P.V.C. ferrules as per wiring diagram.
- xxiii. Proper shrouding to incoming and outgoing terminals shall be provided to ensure safety during operation, inspection and maintenance.
  - xxiv. Indicating lamps shall be with multiple LEDs & shall be suitable for the voltage specified.
  - xxv. All the components in the panel shall be properly labeled. The labels shall be made of non-rusting metal or engraved PVC material properly fixed by screws.
  - xxvi. The panel layout shall be made in such a way that it will always facilitate easy removal and reconnection of control cables without disturbing other wiring.
  - xxvii. Centre lines of control switches, push buttons and indicating lamps shall be matched so as to give neat appearance. Similarly top lines of indicating instruments and relays shall also be matched.
  - xxviii. The panel shall be provided with electrolytic grade aluminium bus-bar of suitable cross section so as to maintain max current density of 0.8 AMP/ Sq.mm.
  - xxix. Bus bars shall be provided with colour coded heat shrinkable sleeves.
  - xxx. Bus bars shall be supported by high quality epoxy insulators provided at specified distances so as to withstand to the given fault level.
  - xxxi. The bus-bar chambers shall be provided with suitable ventilation arrangements so as to limit the maximum temperature of 85°C while carrying rated current.
  - xxxii. Proper clearance of minimum 25 mm shall be maintained between phase bus bars and between bus bars.
  - xxxiii. The panel shall be inspected at manufactures works before dispatch to site at the discretion of JREDA.
  - xxxiv. All routine tests shall be carried out on the panel in presence of the Company / its representative. These tests shall include following:
    - xxxv. Verification of components ratings and operation.
    - xxxvi. High voltage measurement test.

#### **2.34. Metering System**

- i. ABT energy meter shall be approved by JBVNL to measure the delivered quantum of energy to the grid for sale. The responsibility of arranging for the meter, its inspection/calibration/testing charges etc. rests with the Contractor. All charges incurred on Meter testing, shall be borne by the Contractor. ABT energy metering system is to be approved by JBVNL.
- ii. Meter must be provided with the necessary data cables.
- iii. Separate metering system has to be provided by contractor for measurements of auxiliary consumption.
- iv. The Bidder shall provide ABT compliant meters at the interface points. Interface metering shall conform to the Central Electricity Authority (Installation and Operation Meters) Regulation 2006 and amendment thereof Commercial settlement of solar Photovoltaic Grid Interactive based power project shall be in accordance with the JREDA order.

- v. Meter shall be suitable for interfacing for synchronizing the built-in clock of the meter by GPS time synchronization equipment existing at the station either through a synchronization pulse received from the time synchronization equipment or through a remote PC synchronized to GPS clock shall also be in the scope of Bidder.
- vi. All charges for testing and passing of the meter with relevant government agency shall be borne by Bidder, JREDA will assist Bidder for necessary document as and when required.
- vii. ABT compliant Energy Meters shall have technical specification as given below (not limited to specified requirement, Bidder can provide Meter with latest facilities):
- viii. Shall be microprocessor-based conforming to IEC 60687 / IEC 62052-11/ IEC 62053-22 / IS 14697
- ix. Shall carry out measurement of active energy (both import and export) and reactive energy (import) by 3-phase, 4 wire principle suitable for balanced/ unbalanced 3 phase load.
- x. Shall have an accuracy of energy measurement of at least Class 0.2S for active energy and at least Class 0.5 for reactive energy according to IEC 60687, and shall be connected to Class 0.2 CT cores and Class 0.2 PT windings.
- xi. The active and reactive energy shall be directly computed in CT & PT primary ratings.
- xii. Shall compute the net MWh and MVARh during each successive 15-minute block metering interval along with a plus/minus sign, instantaneous net MWh, instantaneous net MVARh, average frequency of each 15 minutes, net active energy at midnight, net reactive energy for voltage low and high conditions at each midnight.
- xiii. Each energy meter shall have a display unit with a seven-digit display unit. It shall display the net MWh and MVARh with a plus/minus sign and average frequency during the previous metering interval; peak MW demand since the last demand reset; accumulated total (instantaneous) MWh and MVARh with a plus/minus sign, date and time; and instantaneous current and voltage on each phases.
- xiv. All the registers shall be stored in a non-volatile memory. Meter registers for each metering interval, as well as accumulated totals, shall be downloadable. All the net active/reactive energy values displayed or stored shall be with a plus /minus sign for export/import.
- xv. The data shall be stored before being over-written for the following parameters or as per latest guidelines:

**Table 0-11**

Sr.	Parameters	Details	Min No of Days.
1	Net MWh	15 min Block	90 days in meter
2	Average Frequency	15 min Block	90 days in meter
3	Net MVARh for > 103 %	15 min Block	90 days in meter
4	Cumulative Net MWh	At every Mid-night	30 days in meter / 90 days in PC

5	Cumulative Net MVARh for v > 103 %	At every Mid-night	30 days in meter / 90 days in PC
6	Date and time blocks of PT failure on any phase		

- Shall have a built in clock and calendar with an accuracy of less than 15 seconds per month drift without assistance of external time synchronizing pulse.
- Date/time shall be displayed on demand. The clock shall be synchronized by GPS time synchronization equipment existing at the station provided by Bidder.
- The meter shall be suitable to operate with power drawn from the PT supplies. The burden of the meters shall be less than maximum 2 VA.
- The power supply to the meter shall be healthy even with a single-phase PT supply. An automatic backup, in the event of non-availability of voltage in all the phases, shall be provided by a built in long life battery and shall not need replacement for at least 10 years with a continuous PT interruption of at least 2 years. Date and time of PT interruption and restoration shall be automatically stored in a non-volatile memory.
- Even under the absence of PT input, energy meter display shall be available and it shall be possible to download data from the energy meters.
- Shall have an optical port on the front of the meter for data collection from either a hand held meter reading instrument (MRI) having a display for energy readings or from a notebook computer with suitable software.
- The meter shall have means to test MWh and MVARh accuracy and calibration at site in-situ and test terminal blocks shall be provided for the same.
- The meter shall have a unique identification code provided by the Company and shall be permanently marked on the front of the meter and stored in the non-volatile memory of the meter.
- The Company shall have the right to carry out surprise inspections of the Metering Systems from time to time to check their accuracy.

### 2.35. SCADA and Remote Monitoring System

- The plant shall be automatically operated and shall be controlled by microprocessor based control system SCADA. There shall be simultaneous data logging, recording and display system for continuous monitoring of data for different parameters of different sub systems, power supply of the power plant at DC side and AC side.

Minimum Requirements of SCADA System for I/O Consideration						
Sr. No.	Equipment Details	Location	SCADA Requirements			
			Monitoring / Status	Control / Operation	Data Logging	Specific Remarks
1	ABT Meter	33kv Metering yard	Yes		Yes	

2	Isolators	33kv Metering yard	Yes			
3	C & R	33kv Switchyard	Yes	Yes	Yes	Relay Log
4	Inverter Duty Transformer / Power Transformer	33kv Metering yard	Yes		Yes	Marshalling Box
5	Breakers	33kv Metering yard	Yes	Yes		
6	33kV VCB Panel	MCR	Yes	Yes	Yes	MFM Meters with RS485
7	DC Battery Charger	MCR	Yes			Battery Back Up Status
8	UPS	MCR / LCR	Yes			UPS Data Log
9	Aux. Transformer	33kv Metering yard	Yes			Marshalling Box
10	Fire Alarm Panel	MCR / LCR	Yes	Yes		
11	String Inverter	PV Array Yard	Yes	Yes	Yes	Inverter Data Log
12	33kV VCB/RMU Panel	LCR	Yes	Yes	Yes	MFM Meters with RS485
13	Weather Monitoring Status	MCR	Yes		Yes	
14	Plant & Switchyard Lighting	Plant & 33kv Metering yard	Yes	Yes		Feedback through ACDB & Light ON/OFF Programming
15	CCTV	LCR / MCR / Plant / Switchyard	Yes		Yes	NVR based recording & data transmission

- ii. An integrated SCADA shall be supplied which should be capable of communicating with all inverters and provide information of the entire Solar PV Grid interactive power plant.
- iii. Computer-aided data acquisition unit shall be a separate & individual system comprising of different transducers to read the different variable parameters, A/D converter, multiplexer, de multiplexer, interfacing hardware & software, which will be robust & rugged suitable to operate in the control room Environment.
- iv. Reliable sensors for solar insolation, temperature, and other weather and electrical parameters are to be supplied with the data logger unit.
- v. The data acquisition system shall measure and continuously record electrical parameters at inverter output, 33 kV ABT meter at evacuation point, ambient temperature near array field,

- control room temperature, AC and DC side electrical parameters of each inverter, power characteristics of the HT side.
- vi. All data shall be recorded chronologically date wise. The data file should be MS Excel compatible. The data logger shall have internal reliable battery backup and data storage capacity to record all sorts of data simultaneously round the clock. All data shall be stored in a common work sheet chronologically and representation of monitored data shall be in graphics mode or in tabulation form. All instantaneous data can be shown in the Computer Screen. Provision should be available for Remote Monitoring.
  - vii. The Bill of Materials associated with the equipment must clearly indicate especially the details about the PC and Printers, etc.
  - viii. The Data Acquisition System should be housed in a desk made of steel sheet.
  - ix. SCADA shall provide following data at a 5 -15 minute interval.
    - a. Power at 33 kV ABT meter at switchyard
    - b. Ambient temperature near array field.
    - c. Wind Speed
    - d. AC and DC side Power of each inverter
    - e. Solar irradiation/isolation
    - f. Voltage of the HT Side
  - x. Any other parameter considered necessary by supplier based on current prudent practice
  - xi. SCADA shall provide 15 minute daily, monthly and annual average of following parameters:
    - Exported Energy to grid at 33 kV
    - Energy of each inverter
    - Solar Radiation
    - Temperature
  - xii. The SCADA server PC shall be of Industrial type, rugged & robust in nature to operate in a hostile environment. The Industrial PC shall have minimum Intel Core i5 processor having 2 X 2 TB HDD with 12 GB RAM. The PC shall also have 42" TFT Color monitor, DVD Drive with Writer, USB drive, Scroll Mouse and UPS for 4 hours Power back up.
  - xiii. The printer shall be of industrial type, rugged & robust in nature and of reputed make. The printer shall be equipped for printing, scanning, copying and fax for A4 & Legal paper size
  - xiv. String Monitoring System (Single String or Dual String): String Monitoring System designed exclusively String Inverter Level, allowing for protection in the case of breakdown & Monitoring the entire photovoltaic field, by means of the following checks.
    - Reading the string currents (10 channels available)
    - Reading the total voltage of the field
    - Checking the fuses positioned in the system, to protect the photovoltaic panels.
    - Checking the state of the internal protection against over-voltages.
    - Should be very low power consumption.
    - Monitoring of various parameters at string level (Single String or Dual String) should be made possible in the main control room at site by installing the suitable string Monitoring system any fault at string level could be recognizable by that system.

- A provision should be present for remote Monitoring of the power plant at string detail over the web.
- The Contractor shall provide to JREDA the detailed specifications, and all administrative rights/ privileges/ passwords to the string Monitoring system.

**2.36. Weather Station and Data logger**

- i. Contractor shall provide the data over remote web-server with rights to control or modify the same through appropriate arrangements.
- ii. Contractor shall provide necessary licensed software and hardware solution to offer Monitoring of electrical parameters of grid and solar generator monitored at individual string level over remote web server. The Contractor shall provide all necessary accessories like power supply, connection cords, sensors, active SIM card with appropriate data plan etc. so as to make the system complete in all respect.
- iii. The cost of data plan during the project and O&M shall be borne by the Contractor. At the end of the O&M, the same shall be transferred to JREDA at no extra cost.
- iv. It shall also have local data logging and communication through Bluetooth / Wi Fi and Ethernet port. Hardwire connection with Ethernet port is also acceptable.
- v. The Remote Monitoring System shall be capable of sustaining maximum – minimum temperature, rainfall, wind gusts and UV radiation. The Annexure shall be IP65 for outdoor installation.
- vi. The Remote Monitoring System shall have capability to log and send data from weather sensors.
- vii. The data shall be available for every minimum 15 minutes interval.
- viii. The system shall have sufficient internal memory storage to retain data for one complete year and shall have provision of expanding memory through external memory card / USB drive.
- ix. The system shall be able to communicate wirelessly in a close proximity
- x. The Contractor shall provide to the Company the detailed specifications, and all administrative rights/ privileges / passwords to the string Monitoring system.
- xi. The Contractor shall provide following measuring instruments with all necessary software & hardware compatible with the Data logging and web based Monitoring system. Reliable sensors for solar insolation, temperature & other weather & electrical parameters are to be supplied with data logger unit.
  - i. **Pyranometer:** The Contractor shall provide two no. of pyranometers for measuring incident global solar irradiance, one each on the horizontal surface and in the same orientation (inclination and azimuth) as the photovoltaic modules. The pyranometers shall have following specifications mentioned below:

**Table 0-12 Specification of Pyranometers**

Sr.	Particulars	Specification
1	Standard	Secondary (Class -A)
2	Spectral Response	0.31 to 2.8 micron
3	Sensitivity	Approx. 9 micro - volt/w/m2
4	Time response (95%)	Max 15 sec.

5	Non-linearity	±0.5%
6	Temperature Response	±2%
7	Temperature Response	Max ±2%
8	Tilt error	±0.5%.
9	Zero offset thermal radiation	±7 w/m <sup>2</sup>
10	Zero offset temperature change	±2 w/m <sup>2</sup>
11	Operating temperature range	- 40 deg. to +80 deg.
12	Uncertainty (95% confidence Level)	Hourly- Max-3%
13	Daily-	Max -2%
14	Non-stability	Max ±0.8%
15	Resolution	Min + / - 1 W/m <sup>2</sup>
16	Input Power for Instrument & Peripherals	230 VAC (If required)
17	Output Signal	Analogue form which is compatible with the data

- ii. Temperature Sensor: The Contractor shall provide suitable nos. of RTD type temperature sensors with required weather shield as per Indian Standards, so as to individually and simultaneously measure both, ambient temperature, and module temperature. To measure module temperature, the temperature sensors shall be located on the back of representative modules. Care must be taken to ensure that the temperature of the cell in front of the sensor is not substantially altered due to the presence of the sensor. Instrument shall have a range of -5°C to 60°C.
- iii. Anemometer and Wind Vane: The Contractor shall provide double cup anemometer on tubular type made up of hot dipped Galvanized Iron. Velocity range upto 65 m/s, accuracy limit of 0.1 m/s. the anemometer shall have valid calibration certificates which should be produced during one month of the installation.
- iv. Each instrument shall be supplied with necessary cables. Calibration certificate with calibration traceability to World Radiation Reference (WRR) or World Radiation Centre (WRC) shall be furnished along with the equipment. The signal cable length shall not exceed 20m. Bidder shall provide Instrument manual in hard and soft form.
- v. The data acquisition system shall measure, continuously record power at PV module ambient temperature near array field, cell temperature, wind velocity, AC and DC (string level) side power of each inverter, power characteristics of the HT side, fault messages, alarms etc. in Indian Standard Time.

- vi. All data shall be recorded chronologically date wise. The data file should be MS Excel compatible. The data logger shall have internal reliable battery backup and data storage capacity to record all sorts of data simultaneously round the clock. All data shall be stored in a common work sheet chronologically. Representation of monitored data in graphics mode or in tabulation form. All instantaneous data can be shown in the Computer Screen.
- vii. Provision should be available for Remote Monitoring and Data Retrieval over web server. Moreover, Successful Bidder shall also provide one no. of PC with required hardware and licensed copies of software to make it fully functional for normal operation and data logging through Bluetooth / Wi Fi / RS port from the site.
- viii. The Bill of Materials associated with the equipment must clearly indicate especially the details about the PC and other accessories.
- ix. The Data Acquisition System should be housed in appropriate Annexure to sustain outdoor environment as per generation design guidelines laid for Annexures. The same shall have provision of locking the same to prevent unauthorized operation. Remote Monitoring System (RMS) shall provide following data at a 15 minute interval.
  - Power, Current and Voltage at individual solar PV strings (Instantaneous)
  - Ambient temperature near array field, cell temperature measured at module front and back surface
  - Wind Speed
  - Cumulative AC and DC side Power of each inverter
  - Cumulative AC and DC energy of each inverter
  - Solar irradiation/isolation over horizontal and in-plane of the module
  - Voltage, frequency and other important electrical parameters etc. in the local grid.
  - Any other parameter considered necessary by supplier based on current prudent practice
- x. All data shall be recorded chronologically date wise. The data file should be MS Excel compatible. The data logger shall have internal reliable battery backup and data storage capacity to record all sorts of data simultaneously round the clock. All data shall be stored in a common work sheet chronologically. Representation of monitored data should be in graphics mode or in tabulation form. All instantaneous data should be shown in the Computer Screen.
- xi. RMS shall have feature to be integrated with the local system as well remotely via the web using either a standard modem or a GSM/WIFI modem. The Bidder shall provide compatible software and hardware so that data can be transmitted via Standard modem.
- xii. RMS shall be provided with independent solar PV based power supply along with maintenance free battery having 3 days autonomy.
- xiii. The RMS shall be compatible to the requirements for measuring and reporting the performance-ratio of the power plant.
- xiv. The contractor shall provide all administrative rights/ privileges/ passwords of the RMS system to JREDA.
- xv. The Bidder shall submit the data sheet with technical specifications of the RMS system in the Bid.

**2.37. Testing Instruments for Electrical & Electronic:**

The Contractor shall also provide required set of onsite testing instruments/equipment viz. earth resistance tester, rheostats, insulation tester, millimetres, clamp meters, CRO, Function Generator, Transformer oil BDV kit, Relay testing kit, infra-red thermal imaging hand held temperature meter, inverter testing kit etc.

**2.38. Electronic LED Display Board:**

The Contractor shall provide an electronic LED Display board that can display the Solar PV plant parameters like total generation till date, daily generation, instantaneous generation, instantaneous frequency, etc. The LED display board has to be erected at a height of 8 feet above ground level and should be large enough to be read from a distance. The LED display board is to be placed between the Control Room and the main gate, the exact location of which will be provided by the Company/ Consultant after award of the project.

Pixel pitch	16.0 mm
Brightness	6,500 nits
LED configuration	DIP / Equivalent
Pixel density	3,906/sqm 363/sqft
Viewing angle	H: 140 degrees V: -45/+15 degrees
Contrast ratio	2,000:1
Lifetime	80,000 hrs
Power consumption	Typical: 220W/sqm; 20W/sqft Max: 480W/sqm; 45W/sqft
Processing	16 bit/color
Refresh rate	4,800 Hz
Operating temperature	-20/+50 degrees Celcius; -4/+122 degrees Fahrenheit
IP rating	IP 65/54
Tile size (WxHxD) in mm	1,024 x 1,024 x 212 mm / 40.3 x 40.3 x 8.3 inches
Serviceability	Front or back
Certifications	CE, UL/ETL, FCC, CB/CEBEC, TUV GS, CCC, RoHs, WEEE

**2.39. CCTV Camera System**

The Contractor shall provide IP Based CCTV Camera for the Monitoring of Control Room, Plant Perimeter, Boundary, Entry & Exit Gates complete in all respect including necessary Camera, NVR, Switch, Active & Passive Components, Software, minimum 32” monitor etc. Minimum 08 Nos. of CCTV Camera of various Indoor / Outdoor with Night Vision Camera to install at each Project Site.

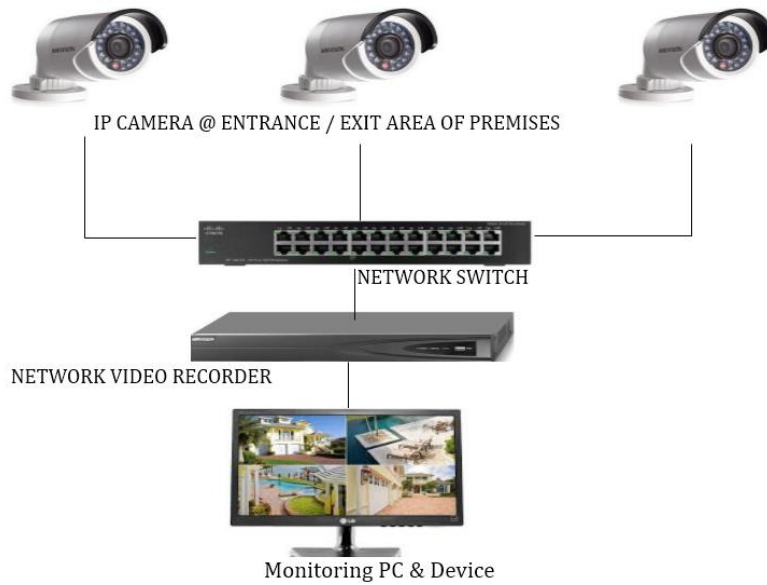

**i. Camera Specification (Outdoor) :**

1/3" CMOS HD sensor, Out Door Bullet H.264 Compression, 2 mega Pixels CMOS, 3DNR, The highest resolution can be up to 1920 × 1080 Low Lux, DWDR, Support Voice talk, 1CH Audio in/1CH Audio Out, Mobile P2P Viewing, Support Protocol: TCP, UDP, IP, HTTP, FTP, SMTP, DHCP, DNS ,ARP, ICMP, POP3, NTP and RTSP, Support ONVIF 2.0, Lens : 2.8-12mm Megapixel lens (4-9mm lens optional), IR Distance: 20-30m, POE (802.3af). Support ROI function, Built-in Micro SD/SDHC/SDXC card slot, Ingress Protection level: IP66, Video Bit Rate 32 Kbps –8 Mbps, Audio Compression G.711/G.722.1/G.726/MP2L2, Dual Stream, BLC, ROI STANDARD: ONVIF, PSIA, CGI, ISAPI ,Operating Conditions -30 °C –60 °C (-22 °F –140 °F).

**ii. Camera Specification (Indoor) :**

1/3" CMOS HD sensor, Indoor Dome fix Lens H.264 Compression, 1.3 mega Pixels CMOS, 3DNR, The highest resolution can be up to 1280×960, Shutter Speed: 1/3 s to 1/100,000s, Min. Illumination: 0.01Lux @ (F1.2, AGC ON) ,0 Lux with IR 0.028 Lux @ (F2.0, AGC ON) ,0 Lux with IR, Video Bit Rate 32 Kbps – 8 Mbps, Support Protocol: TCP, UDP, IP, HTTP, FTP, SMTP, DHCP, DNS, ARP, ICMP, POP3, NTP and RTSP, Support ONVIF 2.0, Lens : 3.6mm 1.3Mega Pixel Lens SD, 3DNR, D-WDR, Motion Detection, Privacy Mask, 24pcs LED, 20m IR distance, POE(802.3af), Support Dual stream , Impact protection : IK10, operating condition, Support ROI, BLC, Standard : ONVIF, PSIA, CGI, ISAPI, Image Settings: Rotate mode, Saturation, Brightness, Contrast adjustable by client software or web browser , H.264 Type: Baseline Profile / Main Profile.

iii. CCTV Cameras along with Monitoring stations (sufficient numbers) and all other accessories required for its proper operation must be installed to have complete coverage of following areas:

- a) Main entry: Covering all the entry/exit 24 hrs,
- b) Control Rooms: Covering Entry/Exit and activities within Control Rooms.

- iv. Contractor has to propose the locations and number of cameras required for the Plant during bidding, however client’s decision on number of cameras shall be final and quantity shall be max upto 10 numbers.
- v. Monitoring stations of the CCTV Network shall be installed in Main Control Room.
- vi. The CCTV system shall be designed as a standalone IP based network architecture. System shall use video signals from different cameras at defined locations, process the video signals for viewing on monitors at control room and simultaneously record all video streams using latest compression techniques.
- vii. Camera shall be colour, suitable for day and night surveillance (even under complete darkness) and network compatible.
- viii. It shall be possible to control all cameras i.e., PTZ auto/ manual focus, selection of pre-sets, video tour selection etc. The software shall support flexible 1/2/4 windows split screen display mode or scroll mode on the display monitor for live video.
- ix. The system shall support video analytics in respect of the following:
  - a) Video motion detection
  - b) Object tracking
  - c) Object classification
- x. Camera server shall be provided with sufficient storage space to storage recordings of all cameras at HD mode for a period of 15 days. All recordings shall have camera ID, location, date and time of recording.

**2.40. Fire Alarm System**

The contractor shall provide Fire Alarm System for LCT, MCR & Control Room as per local CFO’s guideline.

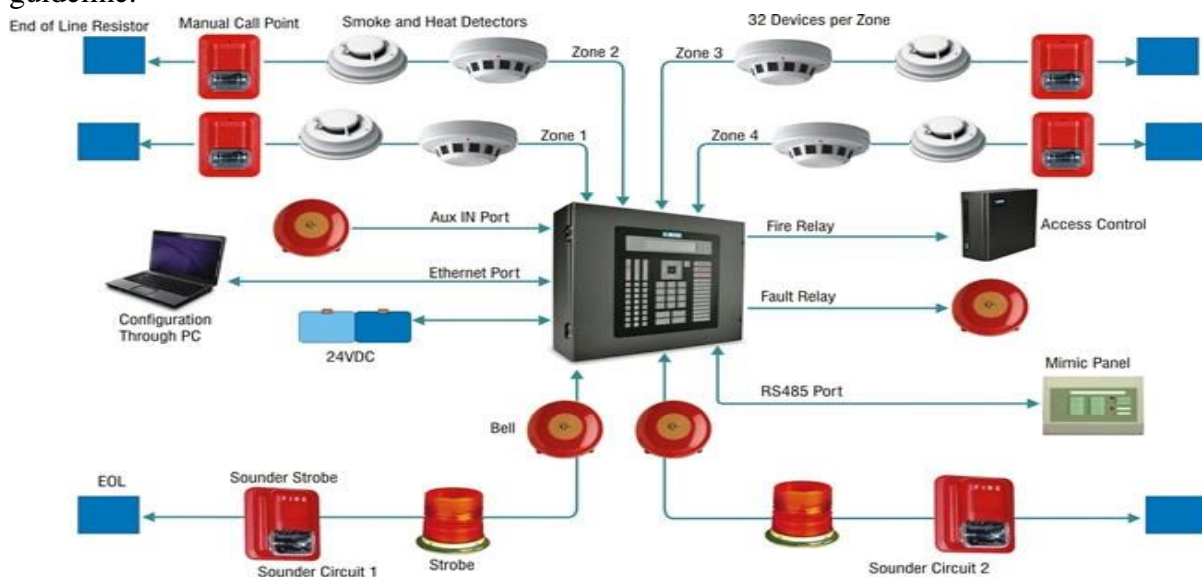

Fire Alarm Panel : Integrated Fire Detection, Alarm and Control System with Voice Evacuation (EVAC) of UL listed Microprocessor based networkable analogue addressable Main Fire Alarm Control having required loop capacity, each loop having capacity of 159 addressable detectors and 159 addressable devices. Panel capacity can be expanded to additional loops by addition of modules or integrating multiple panels. Panel costs to include power supply, 24VDC power supply automatic battery charger, 24 volts sealed lead acid batteries sufficient for 24 hours normal working and then be capable of operating the system for 2 hours during emergency conditions. The system should be complete with user-friendly programming and configuration tools, front panel operating with a full QWERTY keypad and alphanumeric 640 character LCD display. The Panel as well as detectors and devices shall be UL 9th edition Approved/Listed and in conformance with international standards such as NFPA 72 2010 edition National Fire Alarm and Signaling Code for Human Life Safety. The complete system as a solution must be supplied from the same make/OEM manufacturer components conforming to these standards. The panel shall have the capability to integrate with SCADA on open protocol.

Smoke Detector: Analog Addressable Multi-Criteria Sensing Type Detector or Heat Detector as per application must be with mounting based LED, Address Switch inclusive of detector base and complete as required. All Detectors must be UL Listed & FM Approved.

Sounder : UL Listed Directional Sounders with 20 hz to 20 khz operating frequency with minimum 8 distinct sound patterns to indicate corridors, Exit doors, Move upward, move down ward etc. to direct Occupants for fast & safe Evacuation as specified in NFPA 72 - 2007 edition complete as per all requirements of technical specifications & contracts works.

Manual Call Point / Glass Break Device: UL listed, Flush or surface mounted Manual Call Point in manufacturers prescribed matching red enamel outlet box complete. All components must be of same manufacturing origin. Monitor, Control Modules & Fault Isolators: UL listed, modules complete with mounting arrangement on junction box as per requirements of contract works.

### **3. Detailed Civil and Other Non-Electrical Work**

All material, installations, fixtures, accessories etc. to be provided shall be as per the relevant IS specifications. These shall be of best quality and of standard manufacturer as approved by the Engineer-In- Charge (EIC) on site, when there are no standard specifications.

The fresh OPC 53 grade cement (Ultratech /Ambuja /Binani /JK Lakshmi ACC/Shree Cement/Dalmia Cement) and TMT steel reinforcement bars Fe 500D (TATA /Jindal /RINL /SAIL /JSW/Electrotherm) shall be used confirming to relevant IS specifications. In case the material make is not specified, the Contractor has to refer list of the approved manufacturers of the Company. In case there non availability of approved manufactures, Company's/ Consultant's approval/consent needs to be taken.

The Contractor has to keep the full proof records of purchase and consumption along with original purchase bills of Cement and Steel as per the Company procedures and rules. The Contractor has to provide best workmanship with skilled manpower for all the civil items as per the standard specifications/ best practice as approved by the Engineer In-Charge (EIC) on site. The booklet of Standard Specifications for Civil Works will be applicable wherever there is dispute in the items of civil works. The Company will not supply any material for this work.

### **3.1. Topographical Survey:**

The Contractor shall do topographical survey of the proposed site at not more than 10 m interval with the help of Total Station or by Drone or by any other suitable standard method of survey. The formation levels of the proposed power plant have to be fixed with reference to High Flood Level of the proposed site. The ground level and plinth level of structures shall be fixed taking into consideration the highest flood level and surrounding ground profiles.

### **3.2. Soil Test:**

- i. Contractor is solely responsible to carry out detailed Geotechnical investigation to ascertain soil parameters of the proposed site for the planning / designing / construction / providing guarantee / warranty of all civil work including but not limited to foundations / piling for module mounting structures, HT lines, 33 kV switchgear equipment etc. The Contractor shall carry out soil investigation through Government approved / NABL certified soil consultant. These reports shall be furnished to the Company and Consultant prior to commencing work. All RCC works shall be provided of required grade of concrete as per relevant IS specifications as well as based on soil data considering appropriate earthquake seismic zone, wind velocity, whether effect, soil characteristics etc.
- ii. The scope of soil investigation covers execution of complete soil exploration including boring, drilling, collection of undisturbed soil sample where possible, otherwise disturbed soil samples, conducting laboratory test of samples to find out the various parameters mainly related to load bearing capacity, ground water level, settlement, and soil condition, CBR value and submission of detail reports along with recommendation regarding suitable type of foundations for Control cum conference and other foundations of the plant by considering worst case result of the bore hole from the all bore hole along with recommendation for soil improvement wherever necessary. The Contractor shall provide certificate of foundation design and Module Mounting Structure (MMS) design from competent licensed structural engineer in support of the foundation and MMS design proposed by him. The design will be done based on considering the worst result among the bore holes. The Contractor has to carry out also Electrical Resistivity Test.

### **3.3. Foundations:**

The foundations should be designed considering the weight and distribution of the structure and assembly, and a maximum wind speed that location as per IS. Seismic factors for the site also have to be considered while making the design of the foundation. All enclosed areas below plinth level have to be aback-filled with sand/ murrum or soil approved from laboratory testing that has to be compacted so as to achieve proctor density of 95%. In any case soil from excavated foundation pits cannot be used for back-filling without being approved for use after testing in Government/ NABL accredited laboratory. Minor Equipment foundations like Weather Monitoring station and Lightning Arrestor in Array field, Street light pole, Security Cabin, Watchmans Cabin, Foundation for pipe line network, String Combiner box/Array Junction Box/String Junction Box etc shall be provided with minimum reinforcement as per criteria mentioned in IS.

### **3.4. Designing of components:**

- i. The Contractor shall carry out Shadow Analysis at the site and accordingly design strings and arrays layout considering optimal use of space, material and man-power and submit all the details / design to Company for its review / suggestions / approval.
- ii. The Contractor shall obtain and study earthquake and wind velocity data for design of module mounting structure, and considering all parameters related to the weathers conditions like Temperature, humidity, flood, rainfall, ambient air etc.
- iii. RCC structures for control room, Pre-fabricated/engineered inverter rooms, Watchman's cabin, Security cabin shall be strictly as per relevant IS standards.

### **3.5. Storage, Construction Power and Water:**

The Contractor shall arrange for the temporary Power Supply, construction water and water requirement for O&M for module cleaning at the site for construction purpose at its own cost.

Cost of Electricity required during construction shall be payable by the Contractor. If contractor wants to apply for temporary connection to Discom then in such company will assist by providing supporting documents for application. Contractor by utilizing such documents can apply for temporary connection. However sole responsibility of getting temporary connection from Discom will on contractor end.

JREDA shall not provide facility for storage of material, and accommodation for labors at site. The Contractor shall make his own arrangement for the same.

### **3.6. Land Development and Cleaning:**

The Contractor shall have to level the site, as required, so as to compact the plant in minimum possible area and also to minimize shading losses because of solar PV module structures. Removal of debris and bush-cutting is mandatory. Leveling & area grading of the site is to be done if required for easy drain of surface water naturally to avoid the accumulation of rainy water in plant area. During execution of work if any hidden masonry / concrete foundation / pipe line etc. found then Contractor has to execute / remove / reroute the same without any financial implication. The bidder shall visit the site to ensure the land development work required. The Contractor has to clean the site from small trees and shrubs, removal of debris, if any; filled the depression area and excavates and level the high level areas wherever required even though contractor follows the natural ground level for entire plant execution. The Contractor can also use the natural contour of the land, if shadow is not affecting the generation. However, the Contractor shall take reasonable care to ensure that the plant is aesthetically designed. Bidder shall have to Level the uneven area of each pocket of the proposed location as per site requirement. If any hidden structure beneath land is found, bidder may leave that portion of leave such portion of land.

### **3.7. Environmental Clearance:**

The developer shall be responsible to obtained environmental clearances as required under Environmental Clearances Act' 1986 and as per Environmental Impact Assessment (EIA) Notification dated 14th Sept 2006.

### **3.8. Watchmen and Security Cabin:**

The Contractor shall provide one (1) number of pre-fabricated/engineered watchman's portable cabin near plant gate for each plant site. The minimum size of watchman's cabin shall be of 3-meter x 3.5 metre and height of 3 meter with toilet unit and appropriate roof at the top. The Contractor shall provide detailed civil, electrical and its fixtures, plumbing and its fixtures, septic tank, soak pit, and inspection chamber with sewer line. Drawings for the watchmen's cabin. The contractor shall have to provide One (1) table, Two (2) chairs and One(1) Almirah with Light and Fan of reputed make for watchmen's cabin. The Contractor shall provide 4 (Four) nos. of pre-fabricated security cabin of size 1.8 mtr. X 1.8 mtr x 2.4 mtr high with appropriate roof at top shall be provided by contractor for each site. Location of the watchman's Cabin and Security Cabin will be as directed by the Company /Consultant.

### **3.9. Area Lighting:**

- i. Area lighting arrangement shall be made to illuminate the entire site with Average 10 lux level for night hours or bad light hours. Area lighting arrangement shall have adequate numbers of galvanized lights poles along the periphery of the plant (50 mm diameter with 3 mm thick at 30 mtr interval).
- ii. The connector box shall be made of stainless steel, Dust & Vermin Proof, which is to be recessed at the base of each Yard Lighting system. The connector box shall have suitable brass or copper made connector terminal.
- iii. The lighting fixtures with control gear shall be mounted on tubular poles of approved height and mounting arrangement.
- iv. All the yard lighting towers, and lighting fixtures shall be effectively grounded using adequate size of GI earthing wires / GI earthing strips.
- v. The lighting poles shall be welded/bolted with the pole of the fencing to avoid shadow on the panels.
- vi. The Area lighting shall be provided throughout the perimeter of the plant boundary.
- vii. The control gear box (non-integral type) shall be encased in the coping.
- viii. Loop in – Loop out power cables shall be brought up to the control gear box through of adequate size for cable protection.
- ix. The cables shall be properly glanded to the control gear box gland plate.
- x. XLPE / PVC insulated armored Cu/Al cables of adequate size shall be used for interconnection and supply of power to Yard lighting systems.
- xi. Cable terminations shall be made with suitable cable lugs & sockets etc, crimped properly and passed through brass compression type cable glands at the entry & exit point of the connector box and at the entry point to MCB distribution Box for controlling the yard lighting system.
- xii. The lighting fixture should be fixed with fencing pole such that it should not cast shadow on Solar PV panel.

### **3.10. Fencing, Water Retaining Wall & Drainage:**

The Palamu site is located next to the Sone River, with a distance of around 800 meters between the site and the river. Since the proposed land is adjacent to the river, special precautions and measures need to be taken by the EPC (Engineering, Procurement, and Construction) contractor

to utilize the land effectively. This may include construct a water retaining wall of height of min. 1.5 mtr above ground and with sufficient width/thickness to retain water pressure. For design of water retaining wall proper Hydrology study, Flood Potential/Assessment and Highest Flood Level studies shall be conducted. This water retaining wall will act as barrier for ingress of water from Sone river and also act as Boundary wall. Additionally, considering the nature of the land, it might be necessary to have a proper drain system in place to drain rainwater effectively by proposing the culvert/gate arrangement. Drainage shall proposed and constructed by contractor and it shall be parallel to Peripheral roads. Drainage shall be of Random Rubble Masonry or Brick Masonry. Masonry shall be in 1:5 Mortar ration and it shall be covered by Plaster in 1:4 mortar ratio. Bottom of Drain shall be PCC in 1:3:6 grade and it shall be covered by Plater.

**3.11. Main Entrance Gate:**

An all-weather main gate with width of at least 6 meter and 2-meter height with sliding roller at bottom shall be erected at the entrance of the plant site. The gate shall be designed such that it should have aesthetic view by creating Arch type structure above the gate in which the Company's name shall be embossed.

**3.12. Roads:**

All roads of the both plant sites shall be of Water Bound Macadam Type (WBM). Its top width shall be 3.75 mtr plus shoulder on both side of 0.5 mtr width (3.75 mtr + 0.5 mtr + 0.5 mtr)

The top of the road from the natural ground shall be decided based on Hydrology and Flood Assessment report but in any case height/thickness of road shall not be less then 450 mm. Bottom Width of the road shall be decided based on the thickness and side slope proposed inn the design. The WBM road shall be provided at entire periphery (on parameter of the land boundary) of the road by keeping sufficient distance from water retaining wall/Fencing. WBM road shall also be provided for connecting the Main Gate, Inverter Rooms, Main Control Room (Control Cum Conference Room) and Switchyard. Design of the road shall be submitted to Company for Approval prior to commencement of the work. Design shall be in accordance to latest revision of MoRD/MoRTH & CBR value. At the intersection of Road to Drainage, Road to Pipeline Network, Road to Cable Corridor proper pipe culvert is to be provided. NP3 pipe shall be used for construction of Pipe Culvert. Pipe culvert have sufficient cushion of sand and reinforced concrete on its top.

**3.13. Landscaping:**

Landscaping of 0.5 mtr width surrounding the Control Cum Conference room shall be provided to get pleasing and aesthetic view of control cum conference room. Pleasing plant and Shrubs shall be grown which is suitable to climate and soil condition.

**3.14. Sintex Water Tank:**

The contractor shall provide readily available Water tank for storage purpose. Readily available Water tank shall be rested on elevated RCC platform. The height of RCC platform shall be 600 mm above the ground level. The Water tank to be installed for capacity equal to 2500 liters/MW. Readily available water tank shall have all plumbing fixtures and valve assembly. Inlet and out let pipe of water tank shall be connected to the pipeline from the bore hole, pipeline designed for module cleaning & pressure pumps and booster pumps.

**3.15. Water supply for Module Cleaning:**

The contractor shall have to drill one (1) number of bore holes of required depth which can cater the water for cleaning the module during O&M period and other requirements of the plants. Pipeline network from Bore Hole to Storage tank and from Storage tank to PV array field. Pipeline Network shall be designed such that it shall supply the water to farthest point of the PV array Field. It shall have Pressure Pump (One Operating and One Standby), Booster Pump and Valve assembly. Proper electric panel within enclosure is to be installed. If ground water is not suitable for cleaning of module then Softener or RO plant needs to be installed as per daily water requirement. The cleaning system shall consist of Pipe line shall be rested on proper reinforced foundation which should be minimum 300 mm above ground and minimum 300 mm below ground. All necessary arrangement for cleaning of the solar panels shall be in the scope of the Contractor.

### **3.16. Prefabricated/engineered Inverter Room and Control Room cum Conference Room:**

- i. All prefabricated structures shall strictly adhere to relevant IS standards towards construction, design, workmanship, materials and ergonomics. At the same time, it shall take into account the convenience and user needs.
- ii. The Contractor shall provide to the Company detailed civil, electrical, plumbing, etc. drawings and equipment specifications for the inverter/ control cum conference room and take approval from the Company/ Consultant. The drawings of panels with the make of components should be approved from the Company.
- iii. Pre-fabricated Inverter Rooms: In case contractor is adopting the central inverters for the project then the Contractor to construct pre-fabricated/engineered Inverter Rooms. The details of each are as below:

Pre-fab/Pre-Engineered Inverter Room shall be of adequate size and should be of standard manufacturer with sufficient lighting points and RCC cable trenches with oil painted edge angle and 10 mm checker plate covers and shall have exhaust chimney and also sufficient ventilation. It shall be designed for wind speed of that locations as relevant IS. All prefab inverter room shall be laid on RCC plinth with sufficient foundation, pedestal column, Plinth beam and 100mm reinforced grade slab upto outer edge of plinth beam with reinforcement as per relevant IS specifications considering seismic zone, wind and soil detail etc. Finished Kotah /Vitrified /Ceramic tile flooring and 100 mm skirting of same tiles shall be provided in inverter room. The plinth shall be minimum 600 mm high from formation level of the plant. Plinth protection shall be given throughout perimeter of width 1.2m for Inverter rooms. Sufficient steps at the entry of the room with finished Kotah on its top and ramp shall be provided for shifting the equipment in the rooms for all Inverter rooms, . Rooms shall be designed such that structural components shall not be visible from inside or outside after wall cladding work is completed. Rainwater pipe at various locations with gutter at the top shall be provided to discharge rainwater. Termite proofing agent shall be applied in Excavation pit, Plinth filling and in Plinth Protection.

Height of the control cum conference room from Flooring top to bottom of False Ceiling shall

be 3 mtr. Minimum 1 mtr gap between false ceiling and Roof the control cum conference room shall be made available for maintenance purpose. Control cum Conference Room shall be laid on RCC plinth with sufficient foundation, pedestal column, Plinth beam and 100mm reinforced grade slab upto outer edge of plinth beam with reinforcement as per relevant IS specifications considering seismic zone, wind and soil detail etc. Control cum conference room shall be of sufficient size. It shall have SCADA Room, Conference Room, Pantry Unit, Toilet unit for Gents & Toilet unit for Ladies, Battery Room Passage and Control Room for equipment with RCC cable trench. Battery room shall have Acid Resistant Tiles, while Control room, SCADA room, Conference room, Pantry and Passage/Lobby shall have 8-10 mm thick Vitrified/Ceramic tiles flooring and Toilet Units shall have Anti Skid ceramic tiles. All rooms shall have a skirting of 100 mm of same flooring tiles. All rooms shall have entry from Passage only. Pantry unit shall have sufficient space & sandwich type platform with Sink and Plumbing arrangement. For entire control cum conference room there should be Two(2) entries for the emergency exit. Control Room shall have Opening of sufficient size for equipment handling purpose which can be operated by 3mtr x 3 mtr rolling shutter. Opening of Rolling Shutter shall be facilitated by Ramp of sufficient slope. At other entries proper steps with flooring of Vitrified tiles shall be provided. Control Rooms shall have RCC cable trenches with oil painted edge angle and 10 mm checker plate covers and shall have sufficient openings for heat dissipation. Termite proofing agent shall be applied in Excavation pit, Plinth filling and in Plinth Protection. Plinth protection shall be given throughout the perimeter of width 1.2 m with rough kotah on its top.

- iv. For pre-fabricated/engineered superstructure for both Inverter Rooms and Control Cum Conference Room the Design of super-structure i.e. Steel Structure like purlin, rafter, columns, truss etc. for fixing the PUF Panels conforming to relevant IS codes and of Jindal/Tata/ RINL make. It shall include all necessary fitting like nuts, bolts, washers etc. of good quality. All structural steel shall be treated with two coats of red oxide and three coats of Oil paint (Asian Paints, Berger, Durex). The gap between base plate of structural members and concrete top of foundation shall be filled with GP-2 grouting material of reputed make. The material of all J-bolts shall be of minimum 5.6 Class.

The Insulated panels should be of required size for roof and walls. The insulated wall and roof panels shall be sandwich type. The panels shall be made out with 0.35mm thick pre coated steel sheet on both side of Poly Urethane Foam (PUF) for both wall and roof. The density of PUF shall be  $40 \pm 2$  kg/m<sup>3</sup> and thermal conductivity shall be within range of 0.019-0.021 W/m<sup>2</sup>K at 10°C. The total thickness of the panels for walls shall be 60mm and for roof is 40mm. The panels shall be joined together by tongue and groove method. The joints of the panels shall be filled with silicon or equivalent filling material. Panels shall be cuts such that the exposure of PUF and patch work is avoided. The fixing of the panels shall be such that there should not be any gaps at joints like wall and roof, wall to wall, etc. from which air and water particle can pass (Air and Water tight). Roof panel shall be extended 300mm from the eaves wall and 150mm from Gable walls. Rain water gutter shall be provided throughout the periphery with rain water pipes (CPVC/UPVC/GI Pipes) with proper clamping at regular interval. Provision of future installation of Solar panels on the top of the roof shall be done by I or C section with Small base plate assembly

- v. Control Room cum Conference Room for both Project Sites: It shall be of adequate size for fixing the panels, battery banks etc. with a) Conference room with conference table with power sockets and chairs for Six (6) person, printer cum scanner, Projector and 2 mtr x 1.5 mtr Screen and one (1) number of 2 ton Split AC of Samsung/ Voltas/ Videocon or Hitachi make; b) SCADA Room with One (1) Work station with Desktop of 48 inch,CPU & Key Board, Drower etc (Latest version) and three (3) Chairs of Godrej/ Durian/ Zuari make and one (1) number of 2 ton Split AC of Samsung/ Voltas/ Videocon or Hitachi make; d) Pantry unit of sufficient size with sandwich type of platform with refrigerator of Voltas/Samsung/LG & Sink & plumbing fixture and exhaust fan; e) Separate Toilet units for Gents with W/C, Wash Basin, Mirror, Towel Rod, Soap Dispenser and Two(2) Urinals. W/C and Urinals are separated by internal door and f) Toilet unit with W/C for Ladies with Wash basin, Towel Rod, Soap dispenser and Mirror;; g) RCC cable trenches with covers and cable trays and all openings of cable entry shall have vemin proofing; h) False ceiling shall be provided in Conference room, SCADA room, Pantry and Passage etc.; i) Lighting points and fixtures with LED Lights and Fans; and j) Plumbing fixtures with Taps, Valves etc.k) Control Room shall have sufficient LED lights, Exhaust Fans and Fans with all lighting fixture. Conference cum control room shall 1000 litre water tank and sloping roof shall have access through ladder. False ceiling of Gypsum board tiles with Armstrong suspended channel system. False ceiling shall be fixed such that at no place suspended ceiling system should be visible. All units/rooms of the Control cum Conference Room shall have marked signage of SS sheet of 1mm along with engraving words and filled with black color. All lighting points like ACDB/DCDB/Switches/Switch box along with Fans, Lights shall be installed properly of standard makes like Bajaj, Khaitan,Crompton,Havells, Phillips.

### **3.17. Air Conditioner for Control Room cum Conference Room:**

The control room shall be equipped with appropriate numbers of fans of Bajaj, Khaitan, Usha make for effective heat dissipation. The SCADA cabin shall have one (1) number split type air conditioning units of 1-ton capacity. Conference room shall have minimum 2 numbers of 1.5-ton capacity of split type of air conditioning unit. Make of the split type air conditioning units shall be of Samsung/ Voltas/ Videocon or Hitachi make.

### **3.18. Toilets:**

Two Toilet units, one for ladies and one for gents in each Control Room cum Conference Room shall be constructed for six (6) persons with following finish:

- a. Dado: dado tiles upto lintel height shall be provided in Toilet units.
- b. Door window: made out of aluminum sections, 6mm wired.
- c. Ventilators: Mechanical exhaust facility with exhaust fans above it.
- d. Plumbing fixtures : Jaquar/ DEE ESS/ Cera/ Perryware/ Kohler
- e. Sanitary ware: Hindware/ Cera or equivalent make.
- f. EWC: 390 mm high with health facet, toilet paper rolls holder and all fittings. (for ladies and gents separately).
- g. Two (2) numbers of Urinals (430 x 260 x 350 mm size) with all fittings of Cera/ Hindware make.
- h. Wash basins: 02 Nos. (550 x 400 mm) with all fittings of Cera, Hindware make.

- i. Bathroom mirrors: 02 Nos. (600 x 450 x 6 mm thick) hard board backing of Saint Gobain/ Godrej make in each bathroom.
- j. CP brass towel rail/Rod: 02 Nos. (600 x 20 mm) with C.P. brass brackets for each bathroom.
- k. 2 Nos. of Soap holder and liquid soap dispensers for each bathroom.
- l. Water Supply for Pantry & Toilets: UPVC/CPVC/GI pipe of standard make shall be used. Overhead water tank shall be of Sintex or equivalent make of 1,000-litre capacity with proper resting facility.
- m. Drainage for Toilets: Drainage pipes shall be of PVC/UPVC/CPVC/GI. Gully trap, inspection chambers, septic tank for 6 person separate for control cum conference room and also soak well to be constructed for above mentioned requirement.

### **3.19. Doors and Windows for Inverter rooms, Control room and Security Cabin:**

Doors and windows shall be made of aluminum sections. All sections shall be 20 microns anodized. Sections of door-frames and window frame shall be of 1mm thick of Jindal, Tata or make approved by client. Door shutters shall be made of aluminum sections and combination of compact sheet and clear float/ wired glass. The control room shall require a sufficient number of windows/ louvers to provide ventilation/ fresh air circulations. All fixtures like door closure, handles, locks, stoppers for doors and windows shall be of Dorma/ Kich /Godrej make. All windows of conference room shall be covered by roller blind curtains.

### **3.20. Module Mounting Structure (MMS):**

- i. The Contractor shall design and construct appropriate civil foundations for MMS.
- ii. The array structure shall be so designed that it will occupy minimum space without sacrificing the output from Solar PV panels at the same time it will withstand wind speeds of the project site location per **IS 875. Site wise wind speed to be mentioned here as per IS875**
- iii. The Contractor shall design, fabricate, supply and install module mounting structures with all required accessories like clamps, nuts, bolts, cable ties etc., The structures can be of fixed/ seasonal tracker are accepted.
- iv. Modules shall be mounted on a non-corrosive support structure (EPDM rubber gasket /Stainless Steel Star Washer). The frames and leg assemblies of the array structures shall be made of hot dip Galvanized steel as per ASTM A123(Column Post, Purlin, Rafter, Bracing etc). Galvanisation thickness shall not be less than 80 microns. Galvanization shall be measure with elcometer or the material can be sent for testing laboratory. No averaging is allowed for measuring the thickness of galvanization. Inner side galvanization with same specification of any hollow components of module mounting structure is mandatory.
- v. If Glavalume is proposes by contractor then minimum thickness of any member shall not be less than 1.2 mm thickness irrespective of design calculation (Min thickness shall not be less than 1.2 mm in any case)Material grade shall be as per IS:2062-2011 & BIS 15961-2012, HDG Steel. All nuts and bolts (fasteners) shall be made very good quality stainless steel of grade SS 304 required for module fixing, and for other components of MMS, superstructure or switchyard, inverter room, control room, etc. in the plant premises the nuts and bolts (fasteners) shall be of Galvanised MS material with minimum Grade HDG: 5.6.
- vi. Pile casting for testing shall be as per IS before approval of drawing & design. Testing of pile by

Government/NABL accredited laboratory.

- vii. The structure shall be designed for simple mechanical and electrical installation. It shall support Solar PV modules at a given orientation, absorb and transfer the mechanical loads to the ground properly. There shall be no requirement of welding or complex machinery at site and is strictly not allowed.
- viii. Seismic factors for the site to be considered while making the design of the foundation/ramming etc. or any technology. The design of array structure shall be based on soil test report of the site and shall be approved from JREDA/Consultant.
- ix. The Contractor has to plan for pilot test like pull out; lateral and compression of minimum 3,3,1 are required to be conducted for each floor at strategic location, immediately. For lateral Pile test, Anchor Pile/Support pile is to be constructed for applying the load. Load shall be applied by proper Jack assembly. Any vehicle/JCB shall not be allowed for applying load to test piles. Based on the results of above-mentioned tests, final approval for design of pile shall be provided.
- x. The material of construction, structural design and workmanship shall be appropriate with a factor of safety of not less than 1.5.
- xi. For multiple module mounting structures located in a single row, the alignment of all modules shall be within an error limit of 5 mm in vertical / horizontal line.
- xii. Modules shall be clamped / bolted with the structure properly. The material of construction shall be Al / Steel. Clamps / bolts shall be designed in such a way so as not to cast any shadow on the active part of a module.
- xiii. Module mounting structures shall also be earthed through proper separate earthing.
- xiv. The Contractor shall provide to the Company the detailed design, specifications and calculations of the MMS and take approval from the JREDA/Consultant.
- xv. The Contractor shall specify installation details of the Solar PV modules and the support structures with appropriate diagrams and drawings.
- xvi. The Module Mounting Structure design shall be certified by a chartered structural engineer and it is mandatory.
- xvii. The Contractor should design the structure height considering highest flood level at the site. The minimum clearance between the lower edge of the module and the ground shall be the higher of (i) above highest flood level at the site and (ii) minimum 500 mm.
- xviii. String Cables should be passed from Pipes and Cable-ties shall be used to hold and guide the Pipes (cables/wires) from the modules to inverters or junction boxes.
- xix. The Contractor shall provide to the Company the detailed design, specifications and calculations of the MMS.
- xx. The Contractor shall specify installation details of the Solar PV modules and the support structures with appropriate diagrams and drawings.
- xxi. The Bidder shall be permitted ramming of the module mounting structure provided that they obtain consent of JREDA. JREDA shall provide such consent once it is convinced that such ramming shall not in any way deteriorate the strength of the structure and shall not reduce the structure's strength to enjoy a working life of more than 25 years.

### **3.21. Fire Safety:**

- i. Fire Extinguisher: Liquefied CO<sub>2</sub> fire extinguisher shall be upright type of capacity 10 kg having IS: 2171. 7 and IS: 10658 marked. The fire extinguisher shall be suitable for fighting fire of Oils, Solvents, Gases, Paints, Varnishes, Electrical Wiring, Live Machinery Fires, and All Flammable Liquid & Gas.

- ii. Fire Alarm System:

Buildings shall have fire detection and alarm system installed as per relevant standards and regulations. The installation shall meet all applicable statutory requirements, safety regulations in terms of fire protection.

- The minimum 2 no. of fire extinguishers (CO<sub>2</sub> and Foam type each) shall be provided at every buildings/enclose, however Contractor must comply with existing building code for fire Protection by NFPA, IS & State Fire Protection Department.
- Sand bucket should be wall mounted made from at least 24 SWG sheet with bracket fixing on wall conforming to IS 2546 at strategic locations.
- The plan for fire extinguishing must be provided by the Contractor to Employer for the approval. No. of Bucket stands with four buckets on each stand shall be provided in the Transformer Yard.

### **3.22. Sand Buckets:**

Sand buckets should be wall mounted made from at least 24 SWG sheet with bracket fixing on wall conforming to IS 2546. Bucket stands with four buckets on each stand shall be provided in the Transformer Yard, Switchyard, Inverter Rooms, Control Cum Conference room, Security cabin and one (1) number each for the area covered by 1 MW for a plant.

### **3.23. Sign Boards:**

The signboard for nomenclature of sufficient size which can visible from a distance containing brief description of various components of the power plant like switchyard, control room, inverter room etc. as well as the complete power plant in general shall be installed at appropriate locations of the power plant. Contractor shall also provide signage for fire and safety wherever required. The Signboard shall be made of steel plate of not less than 3 mm thick. Letters on the board shall be with appropriate illumination arrangements. The Contractor shall provide to the Company, detailed specifications of the signboards. The language of instructions shall be English/ Hindi as per JREDA's approval.

### **3.24. General Guideline:**

Any civil or electrical work, which is not mentioned or included in this Tender Document but necessary for the plant shall be borne by the Bidder. Successful Bidder shall prepare all designs / drawings have based on the specifications given in the Tender and in light of relevant BIS standard. The Company reserves the right to modify the design at any stage, to meet local site conditions / project requirements. All work shall be carried out in accordance with the latest edition of the Indian Electricity Act and rules formed there under and as amended from time to time.

### **Disclaimer:**

1. Any civil / electrical / other work, which is not mentioned or included in this Tender Document but necessary for the plant shall be borne by the Bidder. All specifications mentioned in this Tender indicates minimum technical requirement.
2. The Contractor may propose alternate specifications or design though the final acceptance of the same is subject to the Company's/Consultant's discretion.
3. Unless otherwise specified, all equipment and materials shall confirm to the latest applicable Indian Standards. Equipment complying with any other International Standards will also be considered if it ensures performance of equipment equal to a superior to Indian Standard.

## **SECTION-7: BID FORMS**

**NIB No. 12/JREDA/SSP/PAL/2024-25**

## DOCUMENT CHECKLIST

### Documents to be attached during online submission of the bid

SL.No.	List of Documents	Copy Attached (Yes/No)	Ref Page No
1.	Scan Copy of Challan / Receipt of Tender Fee submission through Online Via SBI Payment gateway of Jharkhand Tender.		
2.	Scan Copy of Challan / Receipt of Earnest Money Deposit through Online Via SBI Payment gateway of Jharkhand Tender.		
3.	Self-attested copy GSTIN		
4.	Firm Registration Certificate, ESIC, PF registration certificate, and Valid Labor License of the Contractor		
5.	Self-attested copy of PAN Card		
7.	Valid Vendor registration certificate of JREDA		
8.	Test Certificates of all components as per requirement		
9.	Covering Letter as per Form-1		
10.	Information about the bidding firm as per Form-2		
11.	Declaration by the bidder as per Form-3		
12.	Power of Attorney for Signing Bid as per Form-4		
13.	Format of Power of Attorney for Joint Venture/Consortium by lead member of JV/Consortium as per Form-5		
14.	Format for Consortium/Joint Venture Agreement as per Form-6		
15.	Letter of Intent By JV/Consortium Partners to Enter into Agreement/Form JV Or Consortium as per Form-7		
16.	Authorized Contact Person for the NIB as per Form-8		
17.	Format of No Deviation Certificate as per Form-9		
18.	Financial Capability Requirement: CA Certificate indicating average minimum annual turnover of during the last three financial years from FY 2021-22, FY 2022-23 & FY 2023-24 as per Form-10		
19.	Financial Capability Requirement: CA Certificate for Net Worth As on 31 <sup>st</sup> March 2023 as per Form-11		
20.	Annual Audited Balance Sheets, Profit & Loss Statement and ITR for FY 2020-21, FY 2021-22 & FY 2022-23		
21.	Technical Capability Requirement: Details of Orders Received and Executed in Last Seven Years as per Form-12		
22.	Format Of Details of Qualified Technical Staff as per Form-13		
23.	Format Of Disclosure of PV Technology Proposed as per form-14		
24.	Format Of Declaration of Compliance as per Form-15		
25.	Declaration by the bidder towards non-Blacklisting/ Debars ( on non-judicial stamp paper)		

**FORM-1: FORMAT FOR COVERING LETTER**

NIB No: 12/JREDA/SSP/PAL/2024-25

(To be submitted in the official letter head of the company)

To,

The Director,

Jharkhand Renewable Energy Development Agency 3rd Floor, S.L.D.C. Building,  
Kusai Colony, Doranda, Ranchi - 834502.

**Sub: Request for Proposal (RfP) for Design, Engineering, Procurement & Supply, Construction, Commissioning and Comprehensive Operation & Maintenance of cumulative 9 MW (AC) Grid connected Ground Mounted Solar PV Power Plant for a period of 25 years on Government Land at Palamu District of Jharkhand**

Sir,

We, the undersigned...[insert name of the 'Bidder'] having read, examined and understood in detail the RFP Document of NIB No. **12/JREDA/SSP/PAL/2024-25** for **Request for Proposal (RfP) for Design, Engineering, Procurement & Supply, Construction, Commissioning and Comprehensive Operation & Maintenance of cumulative 9 MW (AC) Grid connected Ground Mounted Solar PV Power Plant for a period of 25 years on Government Land at Palamu District of Jharkhand**, System hereby submit our Bid comprising of Price Bid and Techno Commercial Bid. We confirm that neither we nor any of our Parent Company / Affiliate/Ultimate Parent Company has submitted Bid other than this Bid directly or indirectly in response to the aforesaid RfP.

2. We give our unconditional acceptance to the NIB No. 12/JREDA/SSP/PAL/2024-25, date 30.08.2024 and RFP Documents attached thereto, issued by JREDA as amended. As a token of our acceptance to the RFP documents, the same have been initiated by us and enclosed with the bid. We shall ensure that we execute such RFP as per the provisions of the RFP and provisions of such RFP Documents shall be binding on us.

3. We have submitted the requisite amount of Tender Fee & "Earnest Money" as per the terms and conditions mentioned in this RfP document.

4. We have submitted our Price Bid strictly as per terms & conditions of this RFP, without any deviations, conditions and without mentioning any assumptions or notes for the Price Bid in the said format(s). The tender is uploaded on [www.jharkhandtenders.gov.in](http://www.jharkhandtenders.gov.in) as per the requirement of the website separately Technical Bid & Financial Bid.

(Signature of Authorized Signatory)

Name:

Designation:

Company Seal:

**FORM-2: INFORMATION ABOUT THE BIDDING FIRM**

NIB No: 12/JREDA/SSP/PAL/2024-25

(To be submitted on the official letter head of the company)

SL. No.	Particulars	
1.	Name of the Bidder ( in case of JV/Consortium, provide each member name )	
2.	Address of Bidder with Telephone, Fax, email	
3.	Address of the Registered Office	
4.	Address of the works	
5.	GPS Co-ordinate of Registered Office	
6.	GPS Co-ordinate of Factory Campus	
7.	Name & Designation of Authorized Signatory for Correspondence	
8.	Nature of Firm (Proprietorship/Partnership Nature of Firm (Proprietorship/Partnership	
9.	Permanent Account Number (PAN)/TIN(Attach proof)	
10.	Firm's Registration Number (Attach proof)	
11.	GST Number (Attach proof)	
12.	Specify the Item Originally Manufactured by the Bidder (SPV module/Electronics/Battery)	
13.	Registration Number of the firm/co. (Copy of Registration Certificate issued by Industry Department)	
14.	Details of in-house testing facility (Attach Proof)	
15.	Office/ Dealer and Service network in Jharkhand with TIN No. (Give details)	
16.	Quoted quantity	
17.	Particulars of Earnest Money	
18.	Place where Materials will be Manufactured	
19.	Place where Materials will be Available for Inspection	
20.	Other details and remarks, if any	

Yours faithfully,

(Signature of Authorized Signatory)

Name:

Designation:

Company seal:

### FORM-3: DECLARATION BY THE BIDDER

NIB No: 12/JREDA/SSP/PAL/2024-25

(To be submitted in the official letter head of the company)

I/We \_\_\_\_\_ (here in after referred to as the Bidder) (in case of JV/Consortium, provide each member name) being desirous of tendering for the rate contract for work under the above-mentioned tender and having fully understood the nature of the work and having carefully noted all the terms and conditions, specifications etc. as mentioned in the tender document, DO HEREBY DECLARE THAT

1. The Bidder is fully aware of all the requirements of the tender document and agrees with all provisions of the tender document.
2. The Bidder is capable of executing and completing the work as required in the tender.
3. The Bidder accepts all risks and responsibilities directly or indirectly connected with the performance of the tender.
4. The Bidder has no collusion with any employee of JREDA or with any other person or firm in the preparation of the bid.
5. The Bidder has not been influenced by any statement or promises of JREDA or any of its employees, but only by the tender document.
6. The Bidder is financially solvent and sound to execute the work.
7. The Bidder is sufficiently experienced and competent to perform the contract to the satisfaction of JREDA.
8. The information and the statements submitted with the tender are true.
9. The Bidder is familiar with all general and special laws, acts, ordinances, rules and regulations of the Municipal, District, State and Central Government that may affect the work, its performance or personnel employed therein.
10. The Bidder has not been debarred or blacklisted by any SNA/ Government Dept. /PSU etc.
11. This offer shall remain valid for Six months from the date of opening of the tender.
12. The Bidder gives the assurance to execute the tendered work as per specifications terms and conditions.
13. The Bidder confirms the capability to supply and install required no. of systems per month.
14. The Bidder accepts that the earnest money be absolutely forfeited by JREDA if the Bidder fails to undertake the work or sign the contract within the stipulated period.

Yours faithfully,  
(Signature of Authorized Signatory)

Name:

Designation:

Company seal:

**FORM-4: FORMAT OF POWER OF ATTORNEY FOR BIDDING COMPANY**

NIB No: 12/JREDA/SSP/PAL/2024-25

**POWER OF ATTORNEY**

(To be on non-judicial stamp paper of appropriate value as per Stamp Act relevant to place of execution.)

NOW, THEREFORE, KNOW ALL MEN BY THESE PRESENTS,

We (name and address of the registered office) do hereby constitute, appoint and authorize Mr. / Ms. (Name and residential address) who is Presently employed with us and holding the position of..... as our attorney, to do in our name and on our behalf, all such acts, deeds and things necessary in connection with or incidental to our bid for NIB No: 12/JREDA/SSP/PAL/2024-25, including signing and submission of all documents and providing information / Bids to Jharkhand Renewable Energy Development Agency, representing us in all matters before [Insert Name], and generally dealing with Jharkhand Renewable Energy Development Agency in all matters in connection with our bid for the said Project.

We hereby agree to ratify all acts, deeds and things lawfully done by our said attorney pursuant to this Power of Attorney and that all acts, deeds and things done by our aforesaid attorney shall and shall always be deemed to have been done by us.

For:

..... Signature

(Name, Designation and Seal)

Accepted by

..... (Signature)

(Name, Designation and Seal)

(Name, Title and Address of the Attorney)

Note: The mode of execution of the Power of Attorney should be in accordance with the procedure, if any, lay down by the applicable law and the charter documents of the executants (s) and when it is so required the same should be under common seal affixed in accordance with the required procedure.

**FORM-5: FORMAT OF POWER OF ATTORNEY FOR JOINT VENTURE/CONSORTIUM**

**(On Non-judicial Stamp Paper of Appropriate value, if required as per laws of the country of the bidder, to be Purchased in the Name of Joint Venture/Consortium to rules applicable to international bidders as per their country)**

KNOW ALL MEN BY THESE PRESENTS THAT WE, the Partners whose details are given hereunder ..... have formed form a Joint Venture/Consortium ( delete which is not applicable) under the laws of ..... and having our Registered Office(s)/Head Office(s) at ..... (hereinafter called the ‘Joint Venture/Consortium’ which expression shall unless repugnant to the context or meaning thereof, include its successors, administrators and assigns) acting through M/s ..... being the Partner in-charge do hereby constitute, nominate and appoint M/s..... a Company incorporated under the laws of ..... and having its Registered/Head Office at ..... as our duly constituted lawful Attorney (hereinafter called “Attorney” or “Authorised Representative” or “Partner In-charge”) to exercise all or any of the powers for and on behalf of the Joint Venture/Consortium in regard to NIB No. 12/JREDA/SSP/PAL/2024-25 Package/Capacity 09 MW. the bids for which have been invited by Jharkhand Renewable Energy Development Agency ( JREDA) (hereinafter called the ‘Employer’) to undertake the following acts:

- To sign and submit proposal and participate in the aforesaid Bid Specification of the Employer on behalf of the “Joint Venture/Consortium”.
- To negotiate with the Employer the terms and conditions for award of the Contract pursuant to the aforesaid Bid and to sign the Contract with the Employer for and on behalf of the “Joint Venture/Consortium”.
- To receive, accept and execute the Contract for and on behalf of the " Joint Venture /Consortium”.
- To do any other act or submit any document related to the above.
- For the above purpose, the person(s) authorized by the Partner In-charge shall be the person(s) authorized to act on behalf of the “Joint Venture/Consortium” as per the Power of Attorney given to him/her/them by the Partner In-Charge,

It is clearly understood that all the partners of the joint venture/Consortium shall be liable jointly and severally for the execution of the Contract in accordance with the Contract terms and the Partner In-charge (Lead Partner) shall ensure performance of the Contract(s) and if one or more Partner fail to perform their respective portions of the Contract(s), the same shall be deemed to be a default by all the Partners.

It is expressly understood that this Power of Attorney shall remain valid binding and irrevocable till completion of the Defect Liability Period in terms of the Contract.

The Joint Venture/Consortium hereby agrees and undertakes to ratify and confirm all the whatsoever the said Attorney/Authorized Representatives/Partner in-charge quotes in the bid, negotiates and signs the Contract with the Employer and/or proposes to act on behalf of the Joint Venture/Consortium by

virtue of this Power of Attorney and the same shall bind the Joint Venture/Consortium as if done by itself.

IN WITNESS THEREOF the Partners Constituting the Joint Venture as aforesaid have executed these presents on this ..... day of ..... under the Common Seal(s) of their Companies.

For and on behalf of the  
Partners of Joint Venture/Consortium.....  
.....

The Common Seal of the above Partners of the Joint Venture/Consortium:

The Common Seal has been affixed there unto in the presence of:

**WITNESS-I**

Signature.....  
Name .....  
Designation .....  
Occupation .....

**WITNESS-II**

Signature.....  
Name .....  
Designation .....  
Occupation .....

**FORM-6: FORMAT FOR CONSORTIUM/JOINT VENTURE AGREEMENT**

**(To be stamped in accordance with Stamp Act, the Non-Judicial Stamp Paper of Appropriate Value should be in the name of the Consortium/Joint Venture)**

THIS JOINT DEED OF UNDERTAKING executed on this..... day of..... Two Thousand and..... by ..... a company incorporated under the laws of ..... and having its Registered Office at .....(hereinafter called the "Party No.1" which expression shall include its successors & executors) and M/s.....a company incorporated under the laws of ..... and having its Registered Office at ..... (hereinafter called the "Party No.2" which expression shall include its successors & executors) and M/s..... a Company incorporated under the laws of ..... and having its Registered Office at ..... (hereinafter called the "Party No.3" which expression shall include its successors & executors) for the purpose of making a bid and entering into a contract [hereinafter called the "Contract" {in case of award}] against the Tender No..... for ..... (insert name of the package along with project name) ..... of Jharkhand Renewable Energy Development Agency ( JREDA) having its registered office at 3rd Floor, S.L.D.C. Building, Kusai Colony, Doranda, Ranchi - 834502., India (hereinafter called the "EMPLOYER").

WHEREAS the Party No.1, Party No.2 and Party No.3 have entered into an Agreement dated.....

AND WHEREAS the EMPLOYER invited bids as per the above-mentioned Specification for the design, manufacture, supply, erection, testing and commissioning including 25 years O & M of Equipment/ Materials stipulated in the Tender Documents under ..... (insert name of the package along with project name) .....

AND WHEREAS Clause in Section-ITB and BDS (documents establishing the Qualification of Bidder) & Qualification Criteria to BDS forming part of the Tender Documents, inter-alia stipulates that an Undertaking of two or more qualified manufacturers as partners, meeting the requirements of Qualification Criteria to BDS, as applicable may bid, provided, the Consortium/Joint venture fulfills all other requirements under Qualification Criteria in Annexure to BDS and in such a case, the Bid Forms shall be signed by all the partners so as to legally bind all the Partners of the Consortium/Joint Venture, who will be jointly and severally liable to perform the Contract and all obligations hereunder.

The above clause further states that this Undertaking shall be attached to the bid and the Contract Performance Security will be as per the format enclosed with the Tender Documents without any restrictions or liability for either party. AND WHEREAS the bid is being submitted to the EMPLOYER vide proposal No..... dated ..... by Party No.1 based on this Undertaking between all the parties; under these presents and the bid in accordance with the requirements in Section-ITB and BDS (documents establishing the Qualification of Bidder) & Qualification Criteria in BDS, has been signed by all the parties.

**NOW THIS UNDERTAKING WITNESSETH AS UNDER:**

In consideration of the above premises and agreements all the parties of this Deed of Undertaking do hereby declare and undertake.

- i. In requirement of the award of the Contract by the Owner/EMPLOYER to the Consortium/JV Partners, we, the Parties do hereby undertake that M/s..... the Party No.1, shall act as Lead Partner and further declare and confirm that we the parties to the Consortium/JV shall jointly and severally be bound unto the Owner/EMPLOYER for the successful performance of the Contract and shall be fully responsible for the design, manufacture, supply and successful performance of the equipment in accordance with the Contract.
- ii. In case of any breach or default of the said Contract by any of the parties to the Consortium/JV, the party(ies) do hereby undertake to be fully responsible for the successful performance of the Contract and to carry out all the obligations and responsibilities under the Contract in accordance with the requirements of the Contract.
- iii. Further, if the Owner/EMPLOYER suffers any loss or damage on account of any breach in the Contract or any shortfall in the performance of the equipment in meeting the performances guaranteed as per the specification in terms of the Contract, the Party(ies) of these presents undertake to promptly make good such loss or damages caused to the Owner/EMPLOYER, on its demand without any demur. It shall not be necessary or obligatory for the Owner/EMPLOYER to proceed against Lead Partner to these presents before proceeding against or dealing with the other Party(ies), the Owner/EMPLOYER can proceed against any of the parties who shall be jointly and severally liable for the performance and all other liabilities/ obligations under the Contract to the Owner/EMPLOYER.
- iv. The financial liability of the Parties of this Deed of Undertaking to the Owner/EMPLOYER, with respect to any of the claims rising out of the performance or non-performance of the obligations set forth in this Deed of Undertaking, read in conjunction with the relevant conditions of the Contract shall, however not be limited in any way so as to restrict or limit the liabilities or obligations of any of the Parties of this Deed of Undertaking.
- v. It is expressly understood and agreed between the Parties to this Undertaking that the responsibilities and obligations of each of the Parties shall be as delineated in this RfP document (to be suitably appended by the Parties along with this Undertaking in its bid) to this Deed of Undertaking. It is further undertaken by the parties that the above sharing of responsibilities and obligations shall not in any way be a limitation of joint and several responsibilities of the Parties under the Contract.

- vi. It is also understood that this Undertaking is provided for the purposes of undertaking joint and several liabilities of the partners to the Consortium/JV for submission of the bid and performance of the Contract and that this Undertaking shall not be deemed to give rise to any additional liabilities or obligations, in any manner or any law, on any of the Parties to this Undertaking or on the Consortium, other than the express provisions of the Contract.
- vii. This Undertaking shall be construed and interpreted in accordance with the provisions of the Contract.
- viii. In case of an award of a Contract, we the parties to this Deed of Undertaking do hereby agree that we shall be jointly and severally responsible for furnishing a Contract Performance Security from a bank in favour of the Owner/EMPLOYER in the currency/ currencies of the Contract.
- ix. It is further agreed that this Deed of Undertaking shall be irrevocable and shall form an integral part of the bid and shall continue to be enforceable till the Owner/EMPLOYER discharges the same or upon the completion of the Contract in accordance with its provisions, whichever is earlier. It shall be effective from the date first mentioned above for all purposes and intents.

IN WITNESS, WHEREOF, the Parties to this Deed of Undertaking have through their authorized representatives executed these presents and affixed Common Seals of their companies, on the day, month and year first mentioned above.

Common Seal of .....  
has been affixed in my/ our presence  
pursuant to Board of Director's Resolution  
dated .....

For Lead Partner (Party No.-1)  
For and on behalf of M/s .....  
(Signature of the authorized representative)

Name .....  
Designation .....  
Signature .....

WITNESS :  
I. ....  
II. ....

Common Seal of .....  
has been affixed in my/ our presence  
pursuant to Board of Director's Resolution  
dated .....

For Lead Partner (Party No.-2)  
For and on behalf of M/s .....  
(Signature of the authorized representative)

Name .....  
Designation .....  
Signature .....  
WITNESS :  
I. ....  
II. ....

Common Seal of .....  
has been affixed in my/ our presence  
pursuant to Board of Director’s Resolution  
dated .....

For Lead Partner (Party No.-3)  
For and on behalf of M/s .....  
(Signature of the authorized representative)

Name .....  
Designation .....  
Signature .....  
WITNESS :  
I. ....  
II. ....

Note:

1. For the purpose of executing the Joint Deed of Undertaking, the non-judicial stamp papers of appropriate value shall be purchased in the name of Consortium/JV.
2. The Undertaking shall be signed on all the pages by the authorized representatives of each of the partners and should invariably be witnessed.

**FORM-7: LETTER OF INTENT BY JV/CONSORTIUM PARTNERS TO ENTER INTO AGREEMENT/FORM JV or CONSOURTIUM**

**(On Non-Judicial Stamp Paper of Appropriate Value, if required as per laws of the country of the bidder, to be Purchased in the Name of Joint Venture or equivalent to rules applicable to international bidders as per their country)**

THIS LETTER OF INTENT signed on this..... Day of..... Two Thousand and.....by..... a company incorporated under the laws of ..... and having its Registered Office at .....(hereinafter called the “Party No.1” which expression shall include its successors, executors and permitted assigns) and M/s.....a company incorporated under the laws of..... and having its Registered Office at..... (hereinafter called the “Party No.-2” which expression shall include its successors, executors and permitted assigns) and M/s. .... a Company incorporated under the laws of..... and having its Registered Office at..... (hereinafter called the “Party No.3” which expression shall include its successors, executors and permitted assigns) for the purpose of making a bid and entering into a contract [hereinafter called the “Contract” {in case of award}] against the Specification No.....for \_\_\_\_\_ (Package) \_\_\_\_\_ associated with \_\_\_\_\_ of Jharkhand Renewable Energy Development Agency ( JREDA) (hereinafter called the ‘Employer’).

WHEREAS the Party No.1, Party No.2 and Party No.3 intend to enter into a Joint Venture/Consortium Agreement

AND WHEREAS the Employer invited bids as per the above mentioned Specification for the design, manufacture, Supply of Equipment Materials stipulated in the bidding documents under \_\_\_\_\_ (Package) \_\_\_\_\_ associated with \_\_\_\_\_.

AND WHEREAS ‘Qualification Requirement of the Bidder’, Section on Evaluation and Qualification Criteria forming part of the bidding documents, inter-alia, stipulates that two or more qualified partners, meeting the requirements of ‘Qualification Requirement of the Bidder’, Section-Evaluation and Qualification Criteria, as applicable may bid, provided, they submit a Letter of Intent to enter into Joint Venture/Consortium Agreement and the Joint Venture Partners fulfil all other requirements under ‘Qualification Requirement of the Bidder’, Section on Evaluation and Qualification Criteria and in such a case, the Letter of Bid (Bid Form) shall be signed by all the proposed partners so as to legally bind all the Partners of the Joint Venture/Consortium, who will be jointly and severally liable to perform the Contract by entering into Joint Venture/Consortium Agreement as per proforma specified in this Section. Bidding Forms of the Bidding Documents which will be legally binding on all partners and all obligations hereunder.

*The above clause further states that this Letter of Intent shall be attached to the bid and the Contract performance guarantee will be as per the format enclosed with the bidding document without any restrictions or liability for either party.*

AND WHEREAS the bid is being submitted to the Employer vide proposal No.....dated..... by Party No.1 based on this Letter of Intent between all the parties; under these presents and the bid in accordance with the requirements of ‘Qualification Requirement of the Bidder’, Section on Evaluation and Qualification Criteria, has been signed by all the parties.

NOW THIS UNDERTAKING WITNESSETH AS UNDER:

In consideration of the above premises and agreements all the parties of this Letter of Intent do hereby declare and undertake:

In requirement of the award of the Contract by the Employer to the Joint Venture/Consortium Partners, we, the Parties do hereby undertake that M/s..... the Party No.1, shall act as Lead Partner and further declare and confirm that we the parties to the Joint Venture/Consortium shall jointly and severally be bound unto the Employer for the successful performance of the Contract and shall be fully responsible for the design, manufacture, Supply, and successful performance of the equipment in accordance with the Contract for which we shall enter into Joint Venture/Consortium Agreement as per proforma specified in this Section IV. Bidding Forms of the Bidding Documents which will be legally binding on all partners:

If the Contract is awarded to Joint Venture/Consortium then in case of any breach or default of the said Contract by any of the parties to the Joint Venture, the party(s) will be fully responsible for the successful performance of the Contract and to carry out all the obligations and responsibilities under the Contract in accordance with the requirements of the Contract.

Further, if the Employer suffers any loss or damage on account of any breach in the Contract or any shortfall in the performance of the equipment in meeting the performances guaranteed as per the specification in terms of the Contract, the Party(s) of these presents will promptly make good such loss or damages caused to the Employer, on its demand without any demur. It shall not be necessary or obligatory for the Employer to proceed against Lead Partner to these presents before proceeding against or dealing with the other Party(s), the Employer can proceed against any of the parties who shall be jointly and severally liable for the performance and all other liabilities/obligations under the Contract to the Employer.

The financial liability of the Parties of the Deed of Undertaking to the Employer in the event of award of Contract on the Joint Venture/Consortium, with respect to any of the claims arising out of the performance or non-performance of the obligations set forth in the Deed of Undertaking, read in conjunction with the relevant conditions of the Contract shall, however not be limited in any way so as to restrict or limit the liabilities or obligations of any of the Parties of the Deed of Undertaking.

It is expressly understood and agreed between the Parties to this Letter of Intent that the responsibilities and obligations of each of the Parties shall be suitably appended by the Parties along with Letter of Intent in its bid). It is further undertaken by the parties that the above sharing of responsibilities and obligations shall not in any way be a limitation of joint and several responsibilities of the Parties under the Contract in the event of award on Joint Venture/Consortium.

It is also understood that this Letter of Intent is provided for the purposes of undertaking joint and several liabilities of the partners to the Joint Venture for submission of the bid and performance of the Contract if awarded and that this Letter of Intent shall not be deemed to give rise to any additional liabilities or obligations, in any manner or any law, on any of the Parties to this Letter of Intent or on the Joint Venture, other than the express provisions of the Contract.

***This Letter of Intent shall be construed and interpreted in accordance with the provisions of the Contract.***

***In case of an award of a Contract, we the parties to this Letter of Intent do hereby agree that we shall enter into Joint Venture/Consortium Agreement as per proforma specified in this Form-6 within 30 days from declaration of L1. Bidding Forms of the Bidding Documents which will be legally binding on all partners, and we shall be jointly and severally responsible for furnishing a Contract***

***performance security from a bank in favor of the Employer in the currency/currencies of the Contract.***

It is further agreed that this Letter of Intent shall be irrevocable and shall form an integral part of the bid. It shall be effective from the date first mentioned above for all purposes and intents.

IN WITNESS WHEREOF, the Parties to this Letter of Intent have through their authorize representatives executed these presents and affixed Common Seals of their companies, on the day, month and year first mentioned above.

**For Lead Partner (Party No.-1)**

For and on behalf of M/s .....  
Common Seal of .....  
Has been affixed in my/ our presence pursuant to Board of Director’s Resolution dated .....

Name .....  
Designation .....  
Signature ..... (Signature of the authorized representative)

**WITNESS:**

- I. ....
- II. ....

**For Lead Partner (Party No.-2)**

For and on behalf of M/s .....  
Common Seal of .....  
Has been affixed in my/ our presence pursuant to Board of Director’s Resolution dated .....

Name .....  
Designation .....  
Signature ..... (Signature of the authorized representative)

**WITNESS:**

- I. ....
- II. ....

**For Lead Partner (Party No.-3)**

For and on behalf of M/s .....  
Common Seal of ..... Has been affixed in my/ our presence pursuant to Board of Director’s Resolution dated .....

Name ..... Signature .....  
(Signature of the authorized representative)

WITNESS:

- I. ....
- II. ....

Designation .....

**FORM-8: AUTHORIZED CONTACT PERSON FOR THE NIB**

NIB No: 12/JREDA/SSP/PAL/2024-25

[On the letterhead of Bidding Company]

1	Contact Person name for the NIB ( Incase of JV/Consortium, Lead member representative details shall be furnished)	
2	Designation	
3	Contact No. (phone & mobile)	
4	Fax No.	
5	e-mail ID	
6	Corresponding address with pin code	
7	Remarks	

Signatory)

(Signature of Authorized

Name:

Designation:

Company

Seal:

**FORM-9: FORMAT OF NO DEVIATION CERTIFICATE**

(To be submitted on the Letter Head of the Bidding Company)

NIB No: 12/JREDA/SSP/PAL/2024-25

Date:

To

The Director,

Jharkhand Renewable Energy Development Agency (JREDA)

3rd Floor, SLDC Building,

Kusai Colony, Doranda

Ranchi-834 002, Jharkhand

Sub: Request for Proposal (RfP) for Design, Engineering, Procurement & Supply, Construction, Commissioning and Comprehensive Operation & Maintenance of cumulative 9 MW (AC) Grid connected Ground Mounted Solar PV Power Plant for a period of 25 years on Government Land at Palamu District of Jharkhand.

Dear Sir,

We, \_\_\_\_\_ (Bidder's name), confirm our acceptance to all terms and conditions mentioned in the Tender Document, and all subsequent clarifications, in totality and withdraw all deviations raised by us, if any.

\_\_\_\_\_

SEAL AND SIGNATURE OF BIDDER

Date: \_\_\_\_\_

## FORM-10 FORMAT FOR FINANCIAL REQUIREMENT – ANNUAL TURNOVER

NIB No: 12/JREDA/SSP/PAL/2024-25

[On the letterhead of Bidding Company or Letter head of the CA firm]

To,

Date:

Director,

Jharkhand Renewable Energy Development Agency (JREDA)

3rd Floor, SLDC Building, Kusai, Doranda, Ranchi- 834002 (Jharkhand)

Dear Sir,

Sub: Request for Proposal (RfP) for Design, Engineering, Procurement & Supply, Construction, Commissioning and Comprehensive Operation & Maintenance of cumulative 9 MW (AC) Grid connected Ground Mounted Solar PV Power Plant for a period of 25 years on Government Land at Palamu District of Jharkhand.

### 1. (Applicable in case of Bidder being a single company- Bidding Company)

We certify that the [Insert name of Bidding Company/ Affiliate or Parent, as applicable] has a Average Annual Turnover of INR [ ] (Indian Rupees \_\_\_\_\_) or equivalent USD, computed as per instructions in RFP, based on unconsolidated audited annual accounts for the last three (3) immediately preceding financial years FY 2020-21, FY 2021-22 & FY 2022-23.:

S. No.	Name of Bidding Company/ Affiliate or Parent whose financial capability is to be considered.	Relationship with the Bidding Company*	Avg. Annual Turnover (INR Crore)
1			
2			

\*The column for 'Relationship with Bidding Company' is to be filled only when the financial capability of Affiliate or Parent is used for meeting the Average Annual Turnover requirement

*(Signature & Name of the person  
authorised by as per PoA or Board)*

*(Signature and Stamp of Statutory  
Auditor/chartered accountant)*

**Company Rubber Stamp**

### Note to Bidders:

- Along with the above format, in a separate sheet, please provide details of computation of Average Annual Turnover duly certified by the statutory auditor/chartered accountant
- Bidder to furnish copy of unconsolidated audited annual accounts of the Financial Year

ending on 31 March (or immediately preceding Calendar Year or the accounting year as adopted by the foreign Bidder in accordance with the laws of the respective country) of itself or its Affiliate/Parent whose credentials are used for meeting the Average Annual Turnover requirement.

- iii. Documentary evidence to establish the relationship of an Affiliate/ Parent, duly certified by the chartered accountant/statutory auditor is required to be attached with the format.
- iv. Audited consolidated annual accounts of Bidder/Affiliate/Parent may be used as per relevant Clause of this RFP.

**2. Applicable in case of Consortium/JV**

**(To be filled by each Member of the Consortium separately on its letterhead including the Lead Member)**

**Name of Member: [Insert name of the Member]**

Average Annual Turnover requirement to be met individually or collectively by the Members of the Consortium, subject to the Lead Member demonstrating at least 50% of the Average Annual Turnover required for qualification.

We certify that the [Insert name of Member/ Affiliate or Parent, as applicable] has a Average Annual Turnover of INR [ ] (Indian Rupees ) or equivalent USD, computed as per instructions in RFP, based on unconsolidated audited annual accounts for the last three (3) immediately preceding financial years FY 2020-21, FY 2021-22 & FY 2022-23.:

Name of Consortium/JV Member	Name of Company /Affiliate or Parent whose Average Annual Turnover is to be considered	Relationship with Member of the Consortium/JV	Avg. Annual Turnover (in INR Million)	Equity Commitment in the Consortium (%)
(1)	(2)	(3)	(5)	(6)
Lead Member		Self		
		[Affiliate/Parent]		
Member 1		Self		
		[Affiliate/Parent]		
[Member 2]		[Self]		
		[Affiliate/Parent]		
				100%

Exchange Rates considered (if applicable)

USD to INR: USD 1 = INR.....

Other Currency..... (Bidder to specify the other currency) 1..... = INR.....

Certificate from the Banker in respect of the Exchange rate is enclosed at Appendix----

*Requirements. Further, documentary evidence to establish the relationship of an Affiliate/Parent, duly certified by the company secretary/chartered accountant is required to be attached with the format.*

We are submitting in a separate sheet, details of computation of Average Annual Turnover duly certified by Statutory Auditor or a Chartered Accountant. The detailed sheet is enclosed at Appendix-

We are enclosing the certified copies of Balance sheet, Profit & Loss Account, Schedules and Cash Flow Statements and Bank statement by bank and other documents in support thereof for confirmation of balance in cash & bank as per the stipulations of the RFP as under:

S. No.	Document Description	Enclosed at Appendix
1		
2		
3.		

*(Signature & Name of the person authorised by as per PoA or Board)*

*(Signature and Stamp of Statutory Auditor/chartered accountant)*

**Company Rubber Stamp**

Date:

**Note: Bidders are advised in their own interest to furnish the detailed computation sheet by Statutory Auditor or Chartered Accountant for determination of Average Annual Turnover along with supporting documents referred therein as per the requirements of RFP without which no claim for Average Annual Turnover shall be considered.**

**Note to Bidders:**

- i. Along with the above format, in a separate sheet, please provide details of computation of Average Annual Turnover duly certified by the statutory auditor/chartered accountant.
- ii. Bidder to furnish copy of unconsolidated audited annual accounts of the last three (3) immediately preceding financial years FY 2021-22, FY 2022-23 & FY 2023-24. (or immediately preceding Calendar Year or the accounting year as adopted by the foreign Bidder in accordance with the laws of the respective country) of itself or its Affiliate/Parent whose credentials are used for meeting the Average Annual Turnover requirement.
- iii. Documentary evidence to establish the relationship of an Affiliate/ Parent, duly certified by the chartered accountant/statutory auditor is required to be attached with the format.

**FORM-11: FORMAT FOR FINANCIAL REQUIREMENT - NET WORTH CERTIFICATE**

NIB No: 12/JREDA/SSP/PAL/2024-25

[On the letterhead of Bidding Company]

To,

Date:

Director,

Jharkhand Renewable Energy Development Agency (JREDA)

3rd Floor, SLDC Building, Kusai,

Doranda, Ranchi- 834002 (Jharkhand)

Dear Sir,

Sub: Request for Proposal (RfP) for Design, Engineering, Procurement & Supply, Construction, Commissioning and Comprehensive Operation & Maintenance of cumulative 9 MW (AC) Grid connected Ground Mounted Solar PV Power Plant for a period of 25 years on Government Land at Palamu District of Jharkhand

**1. (Applicable in case of Bidder being a single company- Bidding Company)**

We certify that the [Insert name of Bidding Company/ Affiliate or Parent, as applicable] has a Net Worth of INR [ ] (Indian Rupees \_\_\_\_\_ ) or equivalent USD, computed as per instructions in RFP, based on unconsolidated audited annual accounts for which qualification is sought by the Bidder as set out in [till 31.03.2023]

S. No.	Name of Bidding Company/ Affiliate or Parent whose financial capability is to be considered.	Relationship with the Bidding Company*	Net Worth (INR Crore)
1			
2			

\*The column for ‘Relationship with Bidding Company’ is to be filled only when the financial capability of Affiliate or Parent is used for meeting the Net Worth requirement

*(Signature & Name of the person authorized by as per PoA or Board)*

*(Signature and Stamp of Statutory Auditor/chartered accountant)*

*Company Rubber Stamp*

**Note to Bidders:**

- v. Along with the above format, in a separate sheet, please provide details of computation of Net

Worth duly certified by the statutory auditor/chartered accountant.

- vi. Bidder to furnish copy of unconsolidated audited annual accounts of the Financial Year ending on 31 March (or immediately preceding Calendar Year or the accounting year as adopted by the foreign Bidder in accordance with the laws of the respective country) of itself or its Affiliate/Parent whose credentials are used for meeting the Net Worth requirement.
- vii. Documentary evidence to establish the relationship of an Affiliate/ Parent, duly certified by the chartered accountant/statutory auditor is required to be attached with the format.

**2. Applicable in case of Consortium/JV**

**(To be filled by each Member of the Consortium/JV separately on its letterhead including the Lead Member)**

**Name of Member: [Insert name of the Member]**

Net Worth shall be positive to be met individually by the Members of the Consortium/JV, subject to the Lead Member.

We certify that the [Insert name of Member/ Affiliate or Parent, as applicable] has a Net Worth of INR [ ] (Indian Rupees) or equivalent USD, computed as per instructions in RFP, based on unconsolidated audited annual accounts for the immediately preceding financial year prior to Proposal Due Date.

Name of Consortium/JV Member	Name of Company /Affiliate or Parent whose Net Worth is to be considered	Relationship with Member of the Consortium/JV	Net Worth (in INR Million)	Equity Commitment in the Consortium/JV (%)
(1)	(2)	(3)	(5)	(6)
Lead Member		Self		
		[Affiliate/Parent]		
Member 1		Self		
		[Affiliate/Parent]		
[Member 2]		[Self]		
		[Affiliate/Parent]		
				100%

Exchange Rates considered (if applicable)

USD to INR: USD 1 = INR.....

Other Currency..... (Bidder to specify the other currency) 1..... = INR.....

Certificate from the Banker in respect of the Exchange rate is enclosed at Appendix----

*Requirements. Further, documentary evidence to establish the relationship of an Affiliate/Parent, duly certified by the company secretary/chartered accountant is required to be attached with the format.*

We are submitting in a separate sheet, details of computation of Net Worth duly certified by Statutory Auditor or a Chartered Accountant. The detailed sheet is enclosed at Appendix-

We are enclosing the certified copies of Balance sheet, Profit & Loss Account, Schedules and Cash Flow Statements and Bank statement by bank and other documents in support thereof for confirmation of balance in cash & bank as per the stipulations of the RFP as under:

S. No.	Document Description	Enclosed at Appendix
1		
2		
3.		

.

*(Signature & Name of the person authorised by as per PoA or Board)*

*(Signature and Stamp of Statutory Auditor/chartered accountant)*

### **Company Rubber Stamp**

Date:

**Note: Bidders are advised in their own interest to furnish the detailed computation sheet by Statutory Auditor or Chartered Accountant for determination of Net Worth along with supporting documents referred therein as per the requirements of RFP without which no claim for Net worth shall be considered.**

### **Note to Bidders:**

- i. Along with the above format, in a separate sheet, please provide details of computation of Net Worth duly certified by the statutory auditor/chartered accountant.
- ii. Bidder to furnish copy of unconsolidated audited annual accounts of the last three (3) immediately preceding financial years FY 2021-22, FY 2022-23 & FY 2023-24. (or immediately preceding Calendar Year or the accounting year as adopted by the foreign Bidder in accordance with the laws of the respective country) of itself or its Affiliate/Parent whose credentials are used for meeting the Net Worth requirement. In the event the Bidding Company or any Member of Consortium was incorporated on or after 1 April 2024.
- iii. Documentary evidence to establish the relationship of an Affiliate/ Parent, duly certified by the chartered accountant/statutory auditor is required to be attached with the format.

## FORM-12: PROJECT EXPERIENCE REQUIREMENT

### Details of Orders Received and Executed in Last Years

NIB No: 12/JREDA/SSP/PAL/2024-25

Details of Orders Received & Executed by the Bidder for Supply of **SPV Power Plant** to SNA/ Govt./ Private Organization during Last Seven Years.

SL. No.	Name of Client (with name and contact information of Contact Person)	Details of Work	PV Project AC/ DC Capacity (in MW)	Details of Performance / Completion certificate	Page number of the Work order/ purchase order submitted	Page number of the Performance / Completion certificate submitted

Yours faithfully,

(Signature of Authorized Signatory)

Name:

Designation:

Company Seal:

Note:

- (a) Attach Photocopies of Purchase Orders/Work Order/LOA
- (b) Attach Photocopies of Certificate of Satisfactory Performance and Commissioning certificate Issued by Concerned Nodal Agency/*PSU*/Govt. Organization/Private Organization
- (c) Separate sheet may be used for giving detailed information in seriatim duly signed with page number. Proof of work order/purchase order/LOA and corresponding performance certificate and Commissioning should be submitted/enclosed in the bid.
- (d) If Performance Certificate/Commissioning certificate is not submitted for any project experience, that project experience shall be not counted for the evaluation.

**FORM-13: FORMAT OF DETAILS OF QUALIFIED TECHNICAL STAFF**

(On the bidder’s letterhead)

Sr. No.	Name	Relevant Qualification	Additional Certifications	Total Years of Relevant Experience	Remarks
1.					
2.					
3.					
4.					
5.					
6.					

*Note: Kindly submit copies of resumes and appropriate certifications with this sheet.*

*Additional sheets may be used to provide accurate information.*

**FORM-14: FORMAT OF DISCLOSURE OF PV TECHNOLOGY PROPOSED**

(On the bidder’s letterhead)

<b>PV MODULE</b>		
Type	:	Select One: <input type="checkbox"/> Poly-crystalline Silicon <input type="checkbox"/> Mono-crystalline Silicon
Manufacturer	:	
Model Number	:	
Module Capacity	:	..... Wp ( More than 540 Wp)
No. of Cells per Module	:	
No. of Modules	:	
<b>PV INVERTER</b>		
Type	:	Confirm Type of Inverter: <input type="checkbox"/> String Inverter
Configuration	:	Select One: <input type="checkbox"/> Independent Operation <input type="checkbox"/> Master-Slave Operation <input type="checkbox"/> Other, Please specify.....
Manufacturer	:	
Model Number	:	
Inverter Capacity	:	..... kW
Number of Inverters	:	
<b>MODULE TRACKING</b>		
Type	:	Select One: <input type="checkbox"/> Fixed <input type="checkbox"/> 1-Axis Manual Seasonal <input type="checkbox"/> 1-Axis, Fixed Tilt, Automatic, Daily Tracking <input type="checkbox"/> 1-Axis, Azimuth, Automatic, Daily Tracking <input type="checkbox"/> 2-Axis, Automatic, Tracking <input type="checkbox"/> Other, Please specify .....

**Note:** Name of 4 (four) PV module Manufacturers and String Inverter Manufacturers is to be provided by the Bidder and if the Bidder is awarded the Contract then out of these Manufacturers of PV modules and String Inverters, the Contractor has to supply the material.

**FORM-15: FORMAT OF DECLARATION OF COMPLIANCE**

**Date:**

To,

**The Director,**

Jharkhand Renewable Energy Development Agency (JREDA)

3<sup>rd</sup> Floor, SLDC Building,

Kusai Colony, Doranda

Ranchi-834 002, Jharkhand

**Sub: Request for Proposal (RfP) for Design, Engineering, Procurement & Supply, Construction, Commissioning and Comprehensive Operation & Maintenance of cumulative 9 MW (AC) Grid connected Ground Mounted Solar PV Power Plant for a period of 25 years on Government Land at Palamu District of Jharkhand**

Dear Sir,

This is to certify that I, \_\_\_\_\_, am the duly authorized signatory appointed on behalf of my organization to submit this Bid. The authorization letter is attached herewith. I agree to all the terms and conditions set forth in this Tender Document.

If awarded the job, the Scope of Work shall also conform to the terms and conditions, as well as specifications indicated in the Tender Document and as finally indicated by the Evaluation Committee.

I further certify that all the information provided in this document is accurate to the best of my knowledge.

Signature: \_\_\_\_\_

Designation: \_\_\_\_\_

Name: \_\_\_\_\_

Organization: \_\_\_\_\_

Address: \_\_\_\_\_  
\_\_\_\_\_

Email: \_\_\_\_\_

\_\_\_\_\_

Phone: \_\_\_\_\_

## **SECTION-8: ANNEXURES**

**NIB No. 12/JREDA/SSP/PAL/2024-25**

## **ANNEXURE-1: FORMAT OF PRICE BID**

**(To be submitted in.pdf file with price and .xls BOQ format bid only. Do Not submit with Technical Part)**

NIB No: 12/JREDA/SSP/PAL/2024-25

To,  
The Director,  
Jharkhand Renewable Energy Development Agency (JREDA)  
3rd Floor, SLDC Building,  
Kusai Colony, Doranda  
Ranchi-834 002, Jharkhand

**Sub: Request for Proposal (RfP) for Design, Engineering, Procurement & Supply, Construction, Commissioning and Comprehensive Operation & Maintenance of cumulative 9 MW (AC) Grid connected Ground Mounted Solar PV Power Plant for a period of 25 years on Government Land at Palamu District of Jharkhand**

Dear Sir,

I, \_\_\_\_\_,

submitting the Financial Proposal for the Bid for “Request for Proposal (RfP) for Design, Engineering, Procurement & Supply, Construction, Commissioning and Comprehensive Operation & Maintenance of cumulative 9 MW (AC) Grid connected Ground Mounted Solar PV Power Plant for a period of 25 years on Government Land at Palamu District of Jharkhand.”, on EPC basis through the Tender Document No-12/JREDA/SSP/PAL/2024-25, confirming that:

- I agree to all the terms and conditions set forth in this Tender Document. If awarded the Project, the implementation of the Project shall also conform to the terms and conditions, as well as specifications indicated in the Tender Document and as finally indicated by the Evaluation Committee.
- Rates quoted in this Bid is for destination prices inclusive of all taxes (unless stated otherwise), levies, duties, packing, forwarding, freight, insurance, loading, unloading, supply, installation, commissioning, and any/all charges for successful Engineering, Supply & Installation, Construction, Comprehensive Operation and Maintenance of “Project” at the Site. The break-up of taxes considered are also furnished in price bid.
- Rates quoted in this Bid are INCLUSIVE of taxes and duties. The statutory variation in taxes

shall be admissible in accordance with relevant clause of Taxes and duties of Tender Document. Under no circumstances shall escalation in the prices of this Tender Document be entertained.

- The details quoted herein stand valid for at least 12 months from the date of opening of the Price Bid.

**Price Quote for Total contract EPC Cost including O&M Cost for 25 Years CMC of 9 MW(AC) SPV Project**

Plant Size	Total Quoted Cost (including GST and including of all other taxes and charges) (In Rs.)		NEEGG for 9 MW (AC) in kWh Shall be more than minimum NEEGG
	In Words	In Figure	
<b>9 MW (AC) Grid connected Solar PV Plant including 25 years CMC</b>			

**Note:**

- i) Above quoted price for **Solar Power Plants** is complete in all respect as per Technical Specifications inclusive of all GST, duties, other taxes, packing, forwarding, transit insurance, loading & unloading, transportation & other charges etc. FOR destination at project location as mentioned in this RfP and inclusive of installation, testing, commissioning, operation & maintenance for 25 years, performance testing and training.
- ii) **Total Quoted Cost (including GST and including of all other taxes and charges) shall be sum of the rate quoted in annexure 2 & 3. In case any discrepancy or variation in the total amount in Annexure 1 from the quoted amount in annexure 2 & 3, the respective bid shall be rejected.**
- iii) **The price bid shall be submitted online only in BOQ format. If any bidder submits the price bid in technical part shall be rejected.**
- iv) Certified that cost quoted for **Solar Power Plants** are as per specifications, terms & conditions mentioned in the bid document.
- v) The bidder shall bid NEEGG more than the minimum NEEGG as defined in this RfP.
- vi) Price will be quoted in complete numeric figure and words.
- vii) More than once cost by same bidder shall be rejected.
- viii) JV/Consortium member shall bid single cost in a form of single bid. More than one bid by the any member shall be rejected.

(Signature of Authorized Signatory)

Name:

Designation: Company Seal:

**ANNEXURE-2: FORMAT FOR PRICE BREAKUP FOR SUPPLY & SERVICES**

(To be submitted in.pdf file with price bid only on letterhead. Do Not submit with Technical Part)

NIB No: 12/JREDA/SSP/PAL/2024-25

S. No.	Items/Service Name	Make	Quantity	Per quantity Rate (Including GST and including of all other taxes and charges) (In Rs.)	Total Cost (Including GST and including of all other taxes and charges) (In Rs.)
1	PV Module				
2	Grid Tied Inverter				
4	Module Mounting Structure				
5	DC Cable				
6	AC Cable				
7	Distribution Boards & Junction Boxes (AC & DC)				
8	Earthing Kit				
9	Lightening Arrestor				
10	Transformer and its components				
11	Other Balance of System (BOS) such as Danger boards, Signages, Fire extinguishers, Drawings and manuals etc.				
12	Supply of Balance of System includes all equipment, materials, spares, accessories, 33 kV Switchyard including 2 nos. of 33 kV Bays at plant level,) etc.				
13	Civil Materials				
14	Monitoring System, SCADA, CCTV and other safety & security items				
15	Any Other items not listed above				
<b>A</b>	<b>Total for Supply Items</b>	<b>In Figure:</b>			
		<b>In Words:</b>			

Request for Proposal (RfP) for Design, Engineering, Procurement & Supply, Construction, Commissioning and Comprehensive Operation & Maintenance of cumulative 9 MW (AC) Grid connected Ground Mounted Solar PV Power Plant for a period of 25 years on Government Land at Palamu District of Jharkhand

S. No.	Items/Service Name	Make	Quantity	Per quantity Rate (Including GST and including of all other taxes and charges) (In Rs.)	Total Cost (Including GST and including of all other taxes and charges) (In Rs.)
16	All Civil works (including Retaining Wall min. 1.5 KM)				
17	All General work required for complete installation and commissioning of the system but not limited to erection, commissioning, testing etc. of entire plant including MMS, 33 kV Switchyard including 2 nos. of 33 kV Bays at Plant Level				
18	Installation, Testing and Commissioning charge				
19	Any other works not mentioned above				
<b>B</b>	<b>EPC Work and Installation, Testing &amp; Commissioning</b>	<b>In Figure:</b>			
		<b>In Words:</b>			
<b>C</b>	<b>Total EPC Cost: Supply + Installation and Commissioning (A+B)</b>	<b>In Figure:</b>			
		<b>In Words:</b>			

### ANNEXURE-3: PRICE QUOTE FOR O&M CONTRACT

(To be submitted in.pdf file with price bid only on letterhead. Do Not submit with Technical Part)

NIB No: 12/JREDA/SSP/PAL/2024-25

Sr. No.	Head	Annual Rate for Comprehensive O&M for 9 MW (AC) excluding GST (A)	GST Amount (B)	O&M charges including GST for 9 MW (AC) (C=A+B)	NEEGG for 9 MW (AC) (D)	Discounting factor for NPV @ 8.30% (E)	NPV of O&M charges for 9 MW (AC) (F=CxE)
		(In Rs.)	(In Rs.)	(In Rs.)	(In kWh)		(In Rs.)
1.	O & M for 1 <sup>st</sup> Year.					1	
2.	O & M for 2 <sup>nd</sup> Year.					0.9234	
3.	O & M for 3 <sup>rd</sup> Year.					0.8526	
4.	O & M for 4 <sup>th</sup> Year.					0.7873	
5.	O & M for 5 <sup>th</sup> Year.					0.7269	
6.	O & M for 6 <sup>th</sup> Year.					0.6712	
7.	O & M for 7 <sup>th</sup> Year.					0.6198	
8.	O & M for 8 <sup>th</sup> Year.					0.5723	
9.	O & M for 9 <sup>th</sup> Year.					0.5284	
10.	O & M for 10 <sup>th</sup> Year.					0.4879	
11.	O & M for 11 <sup>th</sup> Year.					0.4505	
12.	O & M for 12 <sup>th</sup> Year.					0.4160	
13.	O & M for 13 <sup>th</sup> Year.					0.3841	
14.	O & M for 14 <sup>th</sup> Year.					0.3547	
15.	O & M for 15 <sup>th</sup> Year.					0.3275	
16.	O & M for 16 <sup>th</sup> Year.					0.3024	
17.	O & M for 17 <sup>th</sup> Year.					0.2792	
18.	O & M for 18 <sup>th</sup> Year.					0.2578	

19.	O & M for 19 <sup>th</sup> Year.					<b>0.2381</b>	
20.	O & M for 20 <sup>th</sup> Year.					<b>0.2198</b>	
21.	O & M for 21 <sup>st</sup> Year.					<b>0.2030</b>	
22.	O & M for 22 <sup>nd</sup> Year.					<b>0.1874</b>	
23.	O & M for 23 <sup>rd</sup> Year.					<b>0.1731</b>	
24.	O & M for 24 <sup>th</sup> Year.					<b>0.1598</b>	
25.	O & M for 25 <sup>th</sup> Year.					<b>0.1475</b>	
<b>D</b>	<b>Total (Words and Figures)</b>						

1. EPC cost & O&M Cost for 25 Years with taxes and duties shall be considered for evaluation of bid.
2. EPC cost & O&M Cost for 25 Years with Taxes and duties the total amount shall be same as filled in the BoQ Excel. (if Total Amount vary from excel price or, bid shall be considered as non-responsive).
3. The quoted cost for CMC service for 25 Years shall not be less than 35% of the entire project cost (Design, Supply, Installation, Testing, commissioning and CMC for 25 years).
4. The Rate for Comprehensive O&M including all taxes for subsequent year shall not be more than 5.72% of the previous year. E.g., The Rate for Comprehensive O&M including all taxes of 3rd Year shall not be more than 5.72% of the 2nd Year.
5. No variation due to change in forex rate shall be admissible.
6. Payment shall be made in Indian National Rupees (INR) only. Bidder(s) has to quote their rate in INR only.
7. Arithmetical errors will be rectified on the following basis: If there is a discrepancy between words and figures, the amount written in words will prevail.
8. GST on supply & Works shall be considered in confirmation with Govt. Of India Notification No. 24/2018-Central Tax (Rate) dtd 31.08.2018.
9. While making payment for each invoice, amount GST and applicable CESS will be kept under retention till submission of documentary proof of payment of GST or till reflection of payment of GST pertains to respective bill amount in GST return for concern order after due verification.

10. All applicable taxes including GST and any surcharge or cess thereon are included in the quoted number.

Signature: \_\_\_\_\_ Designation: \_\_\_\_\_

Name: \_\_\_\_\_

Address: \_\_\_\_\_

\_\_\_\_\_ Seal of Organization:

\_\_\_\_\_ Phone:

Email: \_\_\_\_\_

#### ANNEXURE 4: BID EVALUATION CRITERIA (BEC)

The Evaluated Bid Value (EBV) shall be calculated using the following parameters:

Parameters Quoted by the Bidder:

- i. Quoted EPC Contract Price,
- ii. Quoted Annual Net Electrical Energy Generation Guarantee (NEEGG) at the metering point of the Plant for each year during the O&M period (of 25 years),
- iii. Quoted O&M Contract Price for each year during the O&M period (of 25 years),

Parameters assumed constant for evaluation of each Bidder:

- iv. Discount Factor of 8.30% annually.

The Evaluated Bid Value (EBV) shall be calculated using the abovementioned parameters as follows:

<b>Step 1</b>		: Quoted EPC Contract Price at the zero <sup>th</sup> (0 <sup>th</sup> ) year
<b>Step 2</b>		: Net Present Value (NPV) of 25 years of O&M Cost quoted by the Bidder
<b>Step 3</b>	ADD	: EPC Contract Price and NPV of O&M for 25 years
<b>Step 4</b>		: Summation of quoted NEEGG for 25 years
<b>Step 5</b>	DIVIDE	(Sum of EPC Contract Price and NPV of each year O&M Contract Price for 25 years) by (Summation of quoted NEEGG for 25 years) i.e. (Step3/Step4)

The Evaluated Bid Value (EBV) shall be the Net Present Value (NPV) as calculated above.

**Evaluated Bid Value (EBV) =**

$$\frac{\text{Total EPC Cost + NPV of each year O\&M Contract Price of 25 years}}{\sum \text{NEEGG of 25 years}}$$

The Bidder with the lowest EBV in Rs./ kwh shall be the Successful Bidder. Bidder with lower EBV in Rs./kWh shall be L-1 and Bidder higher than that shall be the L-2 and so on.

## **ANNEXURE 5: PROCEDURE FOR PERFORMANCE TESTING**

### **Part A: Solar PV power plant Net power generation**

1. The Contractor shall quote the 'Net Electrical Energy Generation Guarantee' for annual basis considering the Reference Global Average Radiation indicated in this Tender.
2. The Contractor shall demonstrate "Actual Delivered Energy" at metering point as compared to the 'Base NEEGG' for every year from the date of starting of O&M Period.
3. The quoted NEEGG for any year shall be permitted with maximum 1 % degradation factor in previous year generation.
4. The quoted NEEGG will be used for the calculating CUF.
5. The Bidder shall clearly mention the technology used i.e., fixed/tilt or seasonal tracker (please specify) as per Table given in Form-14.

### **Operational Acceptance Test Procedure Performance Ratio (PR) - Test Procedure**

1. Performance Ratio as determined through the PR Test Procedure specified here should not be less than 0.75 for Operational Acceptance Test.
2. The Performance Ratio Test to prove the guaranteed performance parameters of the power plant shall be conducted at site by the Contractor in presence of the Company. The Contractor's Engineer shall make the plant ready to conduct such tests. The Operational Acceptance Test shall be commenced, within a period of one (1) month after successful Commissioning and, there will be continuous Monitoring of the performance for 30 days. Any extension of time beyond the above one (1) month shall be mutually agreed upon. These tests shall be binding on both the parties to the contract to determine compliance of the equipment with the guaranteed performance parameters. This Monitoring will be performed on the site under the supervision of the Company/ Company's engineer.
3. The test will consist of guaranteeing the correct operation of the plant over 30 days, by the way of the efficiency rate (performance ratio) based on the reading of the energy produced and delivered to the grid and the average incident solar radiation. During this period of 30 days. If the PR of these 30 days is above 75%, then Operational Acceptance Test (OAT) shall be considered successful.
4. PR shall be demonstrated against the installed DC Capacity.

5. The Efficiency or performance ratio (PR) of the PV Plant is calculated as follows (according to IEC 61724)

$$\text{Performance Ratio (PR)} = Y_A / Y_R$$

Where;

$Y_A$  = Final (actual measured) PV system yield in kilo-watt hours at the point of measurement during the testing period, and

$Y_R$  = Reference yield calculated as the product of the insolation on the plane of the collector (i.e. PV modules) in kWh/ m<sup>2</sup> during the testing period and the installed DC capacity of the plant in kW.

= [Insolation on the plane of the collector (i.e. PV modules) in kWh/ m<sup>2</sup> during the testing period] x Area of the collector of Installed DC Capacity x Installed DC Capacity  
= (kWh/m<sup>2</sup>) x m<sup>2</sup> x Installed DC Capacity

### Monitoring System for PR Verification

The following instrumentation will be used to determine the Solar Plant Performance:

- Power Meter at the delivery point.
- Power Meter for each inverter for reference only.
- One nos. calibrated pyranometer to determine irradiance on the plane of array (with a target measurement uncertainty of  $\pm 2$ ).
- One nos. calibrated pyranometer to determine irradiance on horizontal plane (with a target measurement uncertainty of  $\pm 2$ )
- Two nos. thermocouples to measure module temperature with a measurement uncertainty of  $\pm 1$  °C.
- Shielded ventilated thermocouple with a measurement accuracy of  $\pm 1$ °C.
- An anemometer mounted on a 10m mast to measure wind speed (without additional shadowing on modules).
- Data measurement shall be witnessed in the format mutually agreed before the start of PR test by the employer and the contractor jointly for the said period.
- The Contractor shall show the specified PR for Operational Acceptance.

### Part C: The procedure for Performance Guarantee Test (PGT) - cum- Final Acceptance Test- shall be as follows:

1. A weather station with a calibrated pyranometer shall be installed by the Contractor at the location mutually agreed by the Contractor and JREDA. The test report for the calibration shall be submitted by the Contractor for approval by JREDA. The calibration should be traceable to

- a national/international laboratory. The output of this pyranometer for shall be logged in the SCADA system.
2. In case the pyranometer is found to be working erratically then immediately the Contractor shall take necessary steps to rectify and/or recalibrate the instrument to the satisfaction of JREDA. However, for the dispute period for which such error has occurred and until the instrument is recalibrated to the satisfaction of JREDA, data from any one of the following list of sources as decided by JREDA will be used:
    - i. A separate pyranometer installed by the Company near the site, if available
    - ii. Average of two closest solar power projects, as identified by JREDA
    - iii. Nearest MNRE weather station
  3. “Actual Delivered Energy” from the plant supplied by the Contractor shall be noted for every month and summed up for entire year. For this purpose, the net delivered energy at the metering point shall be taken into account.
  4. The measured value of energy at step (3) shall be compared with ‘*Base NEEGG*’ and hence with ‘*Base CUF*’ value. “*Base NEEGG/ CUF*” for a month is calculated by using the NEEGG quoted in the offer by the Contractor adjusted with a correction factor to take into account the actual average global solar radiation measured by the calibrated pyranometer for that year.
  5. Further, if the plant is not able to achieve the calculated *Base NEEGG/ CUF* during PGT and O&M period and there is a shortfall in energy generation, then the Contractor shall be penalized as per relevant Clause of the Tender.
  6. The Contractor shall share with JREDA all the radiation, generation, etc. parameters details and all other factors necessary for JREDA to corroborate the estimate. JREDA has the right to cross verify data submitted by the Contractor by all possible means/sources.

**Following factors may be noted for computing the Base NEEGG/ CUF:**

1. Effect due to variation in annual insolation shall only be considered for computing the Base NEEGG/ CUF.
2. Effect due to variation of meteorological parameters e.g. ambient temperature, wind speed, humidity etc. shall not be considered.
3. **Generation loss due to grid outage:** The measured global solar radiation of the period of the outage of the power evacuation system shall be excluded to calculate average global solar radiation for the period of PGT and O&M.

**Illustration:**

If the GHI of a year is more or less then the reference GHI then Base NEEGG will be calculated as follows:

Base NEEGG = (Actual GHI x NEEGG guaranteed by contractor on reference GHI)/ (Reference GHI)

NEEGG guaranteed by Contractor = 92,57,201 KWh

Reference GHI= 1745.2 KWh/m<sup>2</sup> per annum

**For Example:**

**Case A) for higher GHI:**

If Actual GHI = 2000 kWh/m<sup>2</sup> per annum then Base NEEGG will be:

$$\text{Base NEEGG} = (2000 \times 92,57,201) / 1745.2$$

$$\text{Base NEEGG} = 1,06,08,757 \text{ KWh/ Annum}$$

**Case B) for lower GHI:**

If Actual GHI = 1600 kWh/m<sup>2</sup> per annum then Base NEEGG will be:

$$\text{Base NEEGG} = (1600 \times 92,57,201) / 1745.2$$

$$\text{Base NEEGG} = 84,87,005 \text{ KWh/ Annum}$$

**ANNEXURE-6: DELIVERY REPORT FORMAT**

NIB No: 12/JREDA/SSP/PAL/2024-25

**Certificate of Delivery of Grid Connected Ground mounted SPV Power Plant received by the Consignee/ JREDA Official as Proof of Compliance by the Supplier**

Name & Designation of  
Consignee:..... Name of  
Department:.....  
.... Address of Department

Certified that we have received following materials and handed over to supplier for installation of Grid Connected SPV Power Plants:

Sr. No.	Details of Item	Quantity	Make	Model	Item Sr. No.

Signature & Seal of Supplier

Signature of Consignee along with Seal/JREDA Official:.....

Date.....

**Certificate of JREDA Representative**

Certified that above-mentioned materials have been inspected as per the specification and handed over to the Supplier at site for installation & commissioning.

Signature & Seal of JREDA Representative

**ANNEXURE-7: PROJECT COMPLETION CERTIFICATE**

NIB No: 12/JREDA/SSP/PAL/2024-25

**Certificate of Installation & Commissioning of the SPV Power Plant Certificate**

Name of Consignee:.....  
Designation:-..... Name of  
Department:.....Address of  
Department:..... This is to certify  
that Solar Power Plant of ----- MW have been installed and commissioned successfully by M/s  
.....,on Dated..... in ..... Building.  
The contractor M/S-----has passed the Operational Acceptance Test on  
dated----- as per JREDA requirement and This Solar Power Plant is working  
satisfactorily from last 6 months days.

Signature & Seal of Supplier

Signature of Consignee along with Seal.....

Date.....

Signature & Seal of JREDA Representative.....

**ANNEXURE-8: DECLARATION FORMAT ASSOCIATED WITH IMPLEMENTATION OF ALMM ORDER**

NIB No: 12/JREDA/SSP/PAL/2024-25

(on the letter head of the bidder)

**To Whomsoever this may concern**

1. We hereby declare that we are fully aware of the binding provisions of the ALMM order and the List as issued by MNRE through its OM No. 283/22/2023- GRID SOLAR/Pt. dated 10<sup>th</sup> May 2023 and its updated list via its OM No. 283/41/2024- GRID SOLAR. dated 24th May 2024 thereunder, while quoting the rate in [*Name of the tender*]
2. We understand that the Updated List (Solar PV Modules) of ALMM Order, of the OM No. 283/41/2024- GRID SOLAR. dated 24th May 2024 and will be updated by MNRE from time to time. We also understand that the Modules to be procured for this project, shall be from the above list ALMM order applicable on the date of invoicing of such modules.
3. We further understand and accept that we shall be liable for penal action, including but not limited to blacklisting and invocation of Performance Bank Guarantee, if we are found not complying with the provisions of ALMM Order, including those mentioned above.

Name:

Designation:

Organization:

Date:

(Signature and Stamp)

**ANNEXURE 9: FORMAT OF PERFORMANCE BANK GUARANTEE**

**For 25 Years CMC Period**

*[To be on non-judicial stamp paper of Rupees One Hundred Only (INR 100/-) or appropriate value as per Stamp Act relevant to place of execution, duly signed on each page.]*

Ref.: \_\_\_\_\_

Bank Guarantee No.: \_\_\_\_\_

Date: \_\_\_\_\_

To,

**The Director,**

Jharkhand Renewable Energy Development Agency (JREDA)  
3<sup>rd</sup> Floor, SLDC Building,  
Kusai Colony, Doranda  
Ranchi-834 002, Jharkhand

**PERFORMANCE BANK GUARANTEE FOR CONTRACT PERFORMANCE**

WHEREAS Jharkhand Renewable Energy Development Agency, incorporated as a society act in year 2001 under the administrative control of the Department of Energy, Govt. of Jharkhand, having its Registered Office at 3<sup>rd</sup> Floor, SLDC Building, Kusai Colony, Doranda, Ranchi, Jharkhand (India) (Hereinafter referred to as the "Company" which expression shall unless repugnant to the context include its successors, executors, administrators, legal representatives and assigns) is setting-up a **09 MW Grid-Connected Ground mounted Solar Photovoltaic Power Plant at Haidarnagar, Palamu, Jharkhand (India)** (Hereinafter referred to as "Project").

WHEREAS the Company has placed a Letter of Intent No..... dated ..... as also a Contract dated..... (hereinafter called the CONTRACT) on; M/s ..... registered in India under the Companies Act, 1956, having its Registered Office..... (Hereinafter referred to as the "Contractor") for setting up of the said Project on the terms, specifications and conditions specified therein for **Design, Engineering, Procurement & Supply, Construction, Commissioning**

**and Comprehensive Operation & Maintenance of cumulative 9 MW (AC) Grid connected Ground Mounted Solar PV Power Plant for a period of 25 years on Government Land at Palamu District of Jharkhand** which shall include any amendments/alterations made in the Tender Document thereto before the date of submission of the Tender by the Company, which has been unequivocally accepted by (the “Contractor”).

AND WHEREAS in conformity with the provisions of Clause No. ....of the said CONTRACT, the “Contractor” has agreed to furnish an unconditional Bank Guarantee for an amount equivalent to 10% of the EPC Contract Price i.e. Rs..... for the timely completion and faithful execution of the Contract and successful completion of the Performance Guarantee Tests of plant equipment to demonstrate the guaranteed values.

AND WHEREAS the Company has agreed to accept a Bank Guarantee for Rs ..... from ..... Bank having its Head Office at .....

Through its Branch..... (hereinafter referred to as the “Bank” which expression shall unless repugnant to the context include its successors and permitted assigns).

In consideration of the above, the “Bank” hereby unconditionally and irrevocably guarantees and undertakes as a direct responsibility, to pay to the Company merely on demand any amount not exceeding Rs. .... without any demure, reservation, recourse, contest or protest and / or without reference to the “Contractor”.

Any such demand made by the “Company” on the “Bank” shall be conclusive and binding notwithstanding any difference between Company and the Contractor or any dispute pending before any Court, Tribunal, Arbitrator or any other authority. The bank undertakes not to revoke this guarantee herein contained and shall continue to be enforceable till the Company discharge this guarantee.

The decision of the Company as to whether the “Contractor” has fulfilled its obligation or not under the CONTRACT shall be final and binding on the “Bank” and the “Contractor”.

The Company shall have the fullest liberty without affecting in any way the liability of “the Bank” under this guarantee from time to time to extend the time for performance of the Contract by the “Contractor”. The Company shall have the fullest liberty without affecting this guarantee, to postpone from time to

time the exercise of any powers vested in them or of any right which they might have against the “Contractor”, and to exercise the same at any time in any manner, and either to enforce or to forebear to enforce any covenants contained or implied in the Contract between the Company and “the Contractor” or any other course of remedy or security available to the Company. The Bank shall not be released of its obligations under these presents by any exercise by the Company of its liberty with reference to matters aforesaid or any of them or by reason of any other act or forbearance to other acts of omission or commission on the part of the Company of any other indulgence shown by the Company or by any other matter or thing whatsoever which under the law would, but for this provision, have the effect of relieving the Bank.

The Bank also agrees that the Company at its opinion shall be entitled to enforce this guarantee against the Bank as a principle debtor, in the first instance without proceeding against “the Contractor”, and notwithstanding any security or other guarantee that the Company may have in relation to “the Contractor's” liabilities.

This Guarantee shall be valid for a period of ..... (Refer NIB) months from ..... i.e. up to ..... The Guarantee herein contained shall be a continuing Guarantee and shall not be affected by any change in the constitution of the “Bank” or of the “Contractor”. This Guarantee shall be in addition to and shall not affect or be affected by any other security now or hereafter held by the Company and Company at its discretion and without any further consent from the Bank and without affecting the liability of the “Bank” and other indulgence to or make other arrangements with the Contractor and nothing done or omitted to be done by the Company in pursuance of any authority contained in this guarantee shall affect or discharge the liability of the Bank.

However, it has been agreed between the Contractor and the Company that there shall be only one composite Bank Guarantee for Performance Guarantee valid for a period of twenty four (24) months from the date of issue of Letter of Intent (LOI) or timeline referred in of *NIB, Table B* whichever is later, as per the terms of the referred Tender Document.

NOTWITHSTANDING anything herein before above contained, the liability of the Bank under this Guarantee shall be restricted to Rs..... <10% of the EPC Contract Price> and the Guarantee shall remain in force up to and including \_\_\_\_\_.

This Bank Guarantee shall be revalidated automatically till the Contract Performance Guarantee is extended.

Bank undertakes not to revoke this guarantee during its currency except with the previous expressed consent of the Company in writing and agrees that any change in the constitution of the Bank or the Contractor shall not discharge our liability hereunder.

IN WITNESS WHEREOF we have set our hands and seal hereunder at this..... day of ..... at .....

For, \_\_\_\_\_ Bank,

Signature: \_\_\_\_\_

Name: \_\_\_\_\_

Designation: \_\_\_\_\_

Address: \_\_\_\_\_

Power of Attorney No. \_\_\_\_\_

Banker's Stamp and Full address

Dated this \_\_\_\_\_ day of \_\_\_\_\_, 20xx

**This is a tentative format for the PBG submission, JREDA may modify this as per requirements, Bidders need to approve this format from JREDA before issuing the final PBG.**

**ANNEXURE-10: FORMAT FOR MONTHLY O&M AND CMC REPORT**

**NIB No: 12/JREDA/SSP/PAL/2024-25**

[On the letterhead of Bidding Company]

To,

The Director,

Jharkhand Renewable Energy Development Agency 3rd Floor, S.L.D.C. Building,  
Kusai Colony, Doranda, Ranchi – 834002.

**Sir,**

**Sub: Request for Proposal (RfP) for Design, Engineering, Procurement & Supply, Construction, Commissioning and Comprehensive Operation & Maintenance of cumulative 9 MW (AC) Grid connected Ground Mounted Solar PV Power Plant for a period of 25 years on Government Land at Palamu District of Jharkhand**

Date of Installation.....

JBVNL Dispatch Order No..... Dated.....

Place of Supply.....

Project Capacity:

Address of the site:

<b>Component</b>	<b>Activity</b>	<b>Description</b>	<b>Date</b>	<b>Name / Signature</b>	<b>*Remarks</b>
PV Module	Cleaning	Immediately clean any bird droppings/dark spots on module.			
	Cleaning	Clean PV modules with plain water or mild dishwashing detergent.			
	Inspection (for plants > 100 kWp)	Infrared camera inspection for hot spots; bypass diode failure.			
PV Array	Inspection	Check the PV modules and rack for any damage.			
	Inspection	If any new objects, such as vegetation growth etc., are causing shading of the array. Remove if any.			
	Vermin	Remove bird nests or			

	Removal	vermin from array and rack area.			
Junction Boxes	Inspection	Inspect electrical boxes for corrosion, intrusion of water or vermin. Check position of switches and breakers. Check status of all protection devices.			
Wiring	Inspection	Inspect cabling for signs of cracks, defects, loose connections, corrosion, overheating, arcing, short or open circuits, and ground faults.			
Inverter	Inspection	Observe instantaneous operational indicators on the faceplate. Inspect Inverter housing or shelter for any physical maintenance. Check for connection tightness.			
Inverter	Service	Clean or replace any air filters.			
Instruments	Validation	Verify monitoring instruments (pyranometer etc.) with standard instruments to verify their operation within tolerance limits.			
Transformer	Inspection	Inspect transformer oil level, temperature gauges, breather, silica gel, meter, connections etc.			
Plant	Monitoring	Daily Operation and Performance Monitoring.			
Spare Parts	Management	Manage inventory of spare parts.			
Logbook	Documentation	Maintain daily log records.			
Tracker (if any)	Inspection	Inspect gears, gear boxes, bearings, motors.			
	Service	Lubricate bearings, gear as required.			

Request for Proposal (RfP) for Design, Engineering, Procurement & Supply, Construction, Commissioning and Comprehensive Operation & Maintenance of cumulative 9 MW (AC) Grid connected Ground Mounted Solar PV Power Plant for a period of 25 years on Government Land at Palamu District of Jharkhand

S No.	Generation kWh	Grid outage (hh:mm)	Inverter down period (hh:mm)	Remarks
1				
2				
3				
4				
5				
6				
7				
8				
9				
10				
11				
12				
13				
14				
15				
16				
17				
18				
19				
20				
21				
22				
23				
24				
25				
26				
27				
28				
29				
30				
31				

*Total generation for the month in kWh:*

*Cumulative generation since commissioning in kWh:*

***CUF for month in %:***

***Cumulative CUF since commissioning in %:***

***\*Provide details of any replacement of systems/components, damages, plant/inverter shut down (planned/forced), breakdown, etc under remarks.***

***\*Daily register is to be maintained by the bidder at each location greater than 50 kWp. The same may be inspected by JREDA or its authorized representative at any time 5 years of O&M period. The Register will have the information about the daily generation, Inverter downtime if any, Grid outages.***

## ANNEXURE 11: DETAILS OF PLANT LOCATION AND SITE ANALYSIS

### Proposed Project Site Location

The identified Parta site is a piece of land owned by the Government of Jharkhand, located at Haidarnagar, Palamu. Haidarnagr is a village panchayat located in the Palamu district of Jharkhand, India. The latitude 24.5280661, and longitude, 83.9204249 is the geo co-ordinate of the Parta site. Nearest City or Town located near Parta is Palamu around 106 Kilometre and JREDA Office at Ranchi is located around 286 kilometres away from site location.

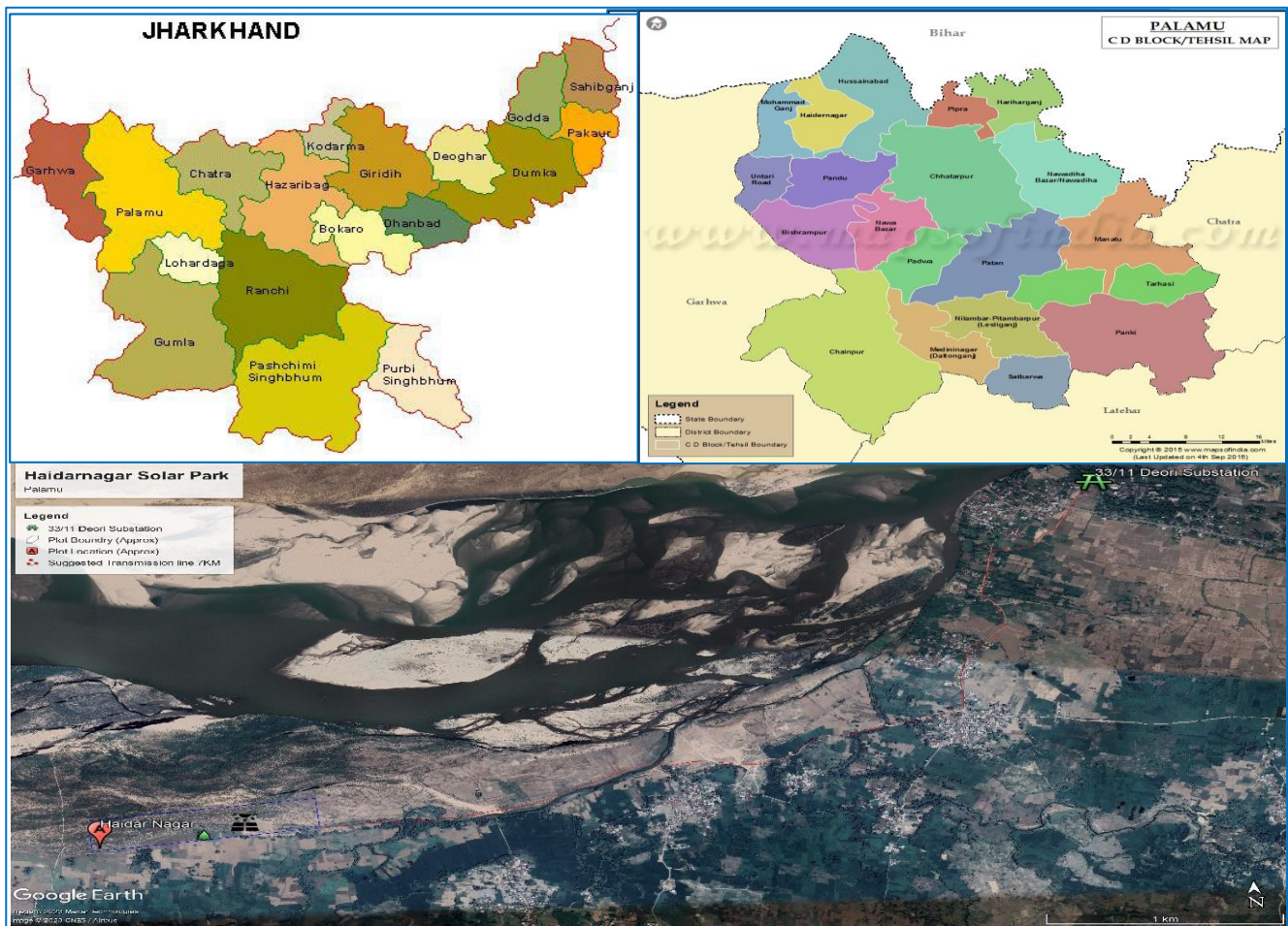

Request for Proposal (RfP) for Design, Engineering, Procurement & Supply, Construction, Commissioning and Comprehensive Operation & Maintenance of cumulative 9 MW (AC) Grid connected Ground Mounted Solar PV Power Plant for a period of 25 years on Government Land at Palamu District of Jharkhand

**Figure 1 Project Location**



**Figure 2 Pictures of Project site**

Request for Proposal (RfP) for Design, Engineering, Procurement & Supply, Construction, Commissioning and Comprehensive Operation & Maintenance of cumulative 9 MW (AC) Grid connected Ground Mounted Solar PV Power Plant for a period of 25 years on Government Land at Palamu District of Jharkhand



**Table 1 Detailed of project site location**

District	Palamu
Tehsil	Haidarnagar
Nearby villages	Parta
Latitude	24.5280661,
Longitude	83.9204249
Altitude	75 M
Approx. Area Available (Upper width *Strech length)	50 acres

Request for Proposal (RfP) for Design, Engineering, Procurement & Supply, Construction, Commissioning and Comprehensive Operation & Maintenance of cumulative 9 MW (AC) Grid connected Ground Mounted Solar PV Power Plant for a period of 25 years on Government Land at Palamu District of Jharkhand

**End of the Document**